

Disintegration process in disc crushers

P. VACULÍK, J. MALOUN, L. CHLÁDEK, M. PŘIKRYL

*Department of Technological Equipment of Buildings, Faculty of Engineering,
Czech University of Life Sciences Prague, Prague, Czech Republic*

Abstract

VACULÍK P., MALOUN J., CHLÁDEK L., PŘIKRYL M., 2013. **Disintegration process in disc crushers.** Res. Agr. Eng., 59: 98–104.

Grinding or crushing hard raw materials is usually a primary operation which precedes the follow-up technological processes in a number of industrial sectors. A great variety of machines using different principles of fragmentation are employed in the technology of pulverization. The food industry uses roller mills, in which the main process is the shear grinding. In the animal feed industry impact machines known as hammer mills are often used. In recent years, mills have been employed that use their frontal edges for grinding or crushing during the rotation of one of two adjacent discs. The modern design disc machines used for grinding grain have resulted from long development and their operation has a relatively low noise level with reduced dust. The separation process that occurs in the gap between the active edges of the discs can be described as shear grinding and is currently the subject of attention which is focused on the specific energy consumption and fractional composition of the product of grinding.

Keywords: grinding process; grinding discs; trajectory of grist fragments; logarithmic spiral

In all of the mentioned methods of separation the material is exposed to normal and shear stresses. Frictional forces are also significantly involved in the grinding process. The amount of energy consumed depends on the manner in which it is passed to the separated particles, the resulting product structure and the properties of the material being ground. As a consequence of the above dependence, the same structure of the product from the same starting raw material can be obtained by exerting different levels of specific energy consumption depending on the method of milling and effectiveness of the grinding equipment. The relationships between the specific energy consumption and the structure of the product of grinding are the fundamental pillars of the theory of the grinding process. Interest in the detailed knowledge of the grinding processes is motivated by effort to contribute to finding ways

leading towards other additional specific energy consumption savings.

The views on the issue of handling solid materials vary considerably. One of many interesting views on the interpretation of the phenomena resulting during the grinding process is, for example, the use of stochastic models (ZUEVA et al. 2010).

MATERIAL AND METHODS

Theoretical analysis and working hypothesis. Processing of raw materials in the disc mill of the current design occurs after their axial entry into the wedge space between the two front edges of the discs. The usual arrangement of the milling system consists of an axially sliding front disc with a central circular orifice to supply raw materials, with an option for smooth

changes in the distance between the active faces of the grinding discs (the so called grinding joints) and the rear disc, rotating in the horizontal axis.

The active grinding surfaces of both discs are provided with grooves. During the rotation at angular velocity ω , after the grist enters into the gap at the beginning of the grinding joint, gradual grinding occurs of both the particles (grains) and their fragments, which, at the same time, move on the disc surfaces along a trajectory that has not been discussed in detail yet.

At the same setting of the basic kinematic and geometric parameters (angular velocity ω , the grinding joint h , grist volumetric flow rate Q , etc.), all particles and their fragments move along the pathways of the same shape, i.e. the same curves.

The perpendicular force which is created by the drive power P is crucial for this disintegration process:

$$P = M \times \omega \quad (W) \quad (1)$$

where:

P – drive power (W)

M – driving torque for the actual grinding (N.m)

ω – angular velocity of the rotating disk (1/s)

After the grist enters between the active surfaces of the discs, this force generates the tangential, centrifugal and Coriolis forces, and their reactions: friction forces, the destructive (disintegration) power and the inertia force (FEYNMAN et al. 2011) (Fig 1).

The problem associated with monitoring the status and behaviour of selected particles (single grains) is complicated by the ever-shrinking characteristic dimension (and thus its mass, i.e. changes

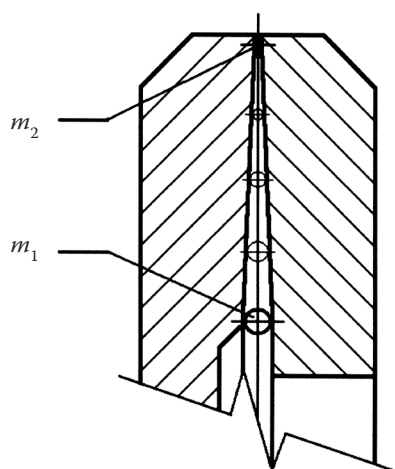

Fig. 1. Movement of particles (fragments) – cross section m_1 – initial mass of particle (kg), m_2 – final mass of particle (kg)

m_1 on m_2), which runs from the input radius to the output from the grinding surfaces.

Trajectories of the gradually separated particles of the processed grain are formed under the effect of the above mentioned forces which can be defined as follows (FEYNMAN et al. 2011):

$$F_n = \frac{M}{r_{\text{mean}}} \quad (N) \quad (2)$$

where:

F_n – perpendicular force created by the disc station (N)

M – driving torque for the actual grinding (N.m)

r_{mean} – mean radius of the active part of a disc (m)

The tangential force is a projection of the force F_n to the tangent of the trajectory curve in the monitored point:

$$F_\gamma = \frac{F_n}{\cos\left(\frac{\pi}{2} - \gamma\right)} \quad (N) \quad (3)$$

where:

F_n – perpendicular force created by the disc station (N)

F_γ – resultant effect of perpendicular and centrifugal forces acting on the curve track (N)

γ – angle between the curve tangent and the vector at a point ($^\circ$)

Centrifugal force F_o , with which the fragments mass m reduces along the trajectory s:

$$F_o = m \times r \times \omega \quad (N) \quad (4)$$

where:

F_o – centrifugal force (N)

m – particle mass (kg)

r – radius forces (m)

ω – angular velocity of the rotating disk (1/s)

Angular velocity of the rotating disk speed ω for $n = \text{const.}$ and $\omega = \text{const.}$:

$$\omega = 2\pi \times n \quad (1/s) \quad (5)$$

where:

ω – angular velocity of the rotating disk (1/s)

n – frequency of rotation (1/s)

Due to its orientation, the Coriolis force F_C causes an additional component of friction T :

$$F_C = 2m \times \omega \times v_{\text{rel}} \quad (N) \quad (6)$$

where:

F_C – Coriolis force (N)

m – particle mass (kg)

ω – angular velocity of the rotating disk (1/s)
 v_{rel} – relative (secondary) speed of a fragment along the vector from the entry to the periphery (m/s)

Friction force:

$$T = N \times f \quad (\text{N}) \quad (7)$$

where:

T – friction force (N)
 N – perpendicular force (N)
 f – coefficient of grist friction on the surface of discs (–)

$$T_C = F_C \times f = 2m \times \omega \times v_{rel} \quad (\text{N}) \quad (8)$$

where:

T_C – supplementary component of friction force, i.e. friction force due to Coriolis force (N)
 F_C – Coriolis force (N)
 f – coefficient of grist friction on the surface of discs (–)
 m – particle mass (kg)
 ω – angular velocity of the rotating disc (1/s)
 v_{rel} – relative (secondary) speed of a fragment along the vector from the entry to the periphery (m/s)

The destructive force is defined using the following equation:

$$F_{dest} = \tau_{dest} \times S \quad (\text{N}) \quad (9)$$

where:

F_{dest} – destruction force (N)
 τ_{dest} – destructive tension between the shear strengths of grain (Pa)
 S – cross section of grain: kx^2 (m²)

For the inertia force F_S the following equation is valid:

$$F_S = m \times a_y = m \times \frac{dv_y}{dt} \quad (\text{N}) \quad (10)$$

where:

F_S – inertial force (N)
 m – particle mass (kg)
 a_y – tangential acceleration (m/s²)
 v_y – tangential velocity of a grist fragment along a trajectory formed by a logarithmic spiral trajectory (m/s)
 t – time (s)

The force of gravity G or its surface effects are ignored here, due to the orientation of the axis of rotation in the horizontal position. The strength of gravity (its components) in the upper halves of the discs acts against the grist leaving the grinding surfaces of discs:

$$G = m \times g \quad (\text{N}) \quad (11)$$

where:

G – gravitation force (N)
 m – particle mass (kg)
 g – acceleration due to gravity (m/s²)

In the lower half an opposite phenomenon occurs. It is obvious that the forces exerted in the vertical plane cancel each other, thus creating an asymmetry of forces and moments relative to the axis of rotation.

In general, the above can be expressed by this vector relationship (SIMMONS 1996; GUZMAN 2003; FEYNMAN at al. 2011):

$$F_n + F_o + F_{dest} - F_S - T - T_C = 0 \quad (\text{N}) \quad (12)$$

where:

F_n – perpendicular force created by the disc station (N)
 F_o – centrifugal force (N)
 F_{dest} – destruction force (N)
 F_S – inertial force (N)
 T – friction force (N)
 T_C – supplementary component of friction force, i.e. friction force due to Coriolis force (N)

On the curve trajectory s the perpendicular force F_n acts together with the centrifugal force F_o . This results in a joint F_y lying on a tangent to the trajectory of the curve, which is followed by a fragment of grist during the grinding process. This happens only on the curve which always forms a constant angle with its vectors.

The friction force T increases with the degree of the particles separation between the discs because the perpendicular force N (pressure on the active edges of discs) increases. This is caused by the total volume of the fragments always being greater than the volume of the original particle (grain).

An additional component of the friction force T_C arises from the Coriolis acceleration orientation, which operates within the meaning of the drifting movement. The destructive force F_{dest} is directly proportional to the transverse cross-section of the particle (fragment), which also decreases in size proportionally along the trajectory.

Fig. 2 also outlines the aspects of the kinematic motion of fragments along the curve's path.

Generally, the vector relation holds:

$$v_Y = v_o + v_{rel} \quad (\text{m/s}) \quad (13)$$

where:

v_Y – tangential velocity of a grist fragment along a trajectory formed by a logarithmic spiral trajectory (m/s)

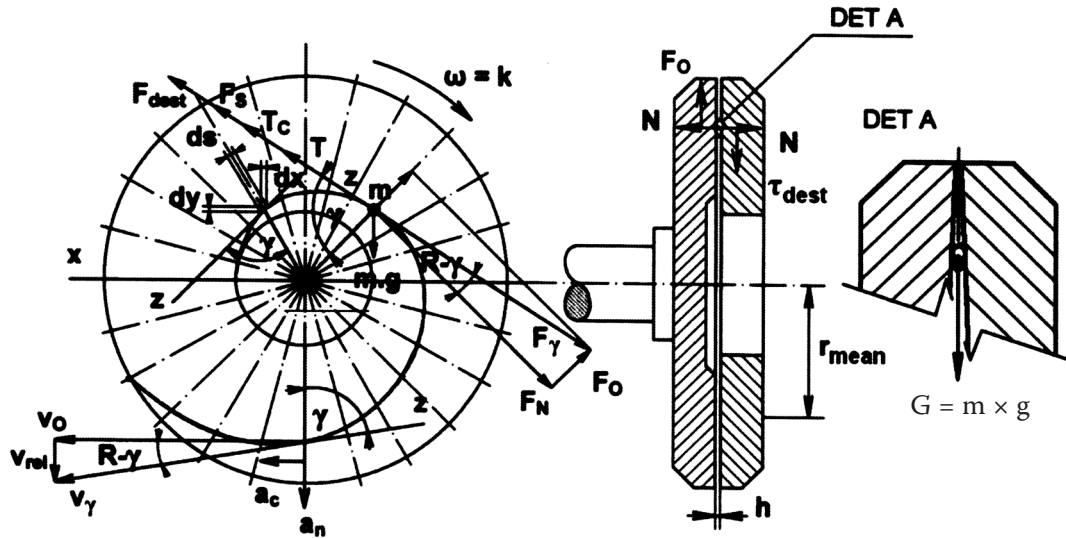

Fig. 2. Action of forces and kinematics of disc grinding

F_{dest} – destruction force (N), F_N – perpendicular force created by the disc station (N), F_o – centrifugal force (N), F_s – inertial force (N), F_γ – resultant effect of perpendicular and centrifugal forces acting on the curve track (N), G – gravitation force (N), N – perpendicular force (N), T – friction force (N), T_c – supplementary component of friction force, i.e. friction force due to Coriolis force (N), g – acceleration due to gravity (m/s^2), h – grinding joint (mm), m – particle mass (kg), r_{mean} – mean radius of the active part of a disc (m), v_γ – tangential velocity of a grist fragment along a trajectory formed by a logarithmic spiral trajectory (m/s), v_o – peripheral speed (m/s), v_{rel} – relative (secondary) speed of a fragment along the vector from the entry to the periphery (m/s), x – characteristic size of a particle (fragment) (m), γ – the angle between the curve tangent and the vector at a point ($^\circ$), τ_{dest} – destructive tension between the shear strengths of grain (Pa), ω – angular velocity of the rotating disk (1/s)

v_o – peripheral speed (m/s)

v_{rel} – relative (secondary) speed of a fragment along the vector from the entry to the periphery (m/s)

where the following is valid for the circumferential velocity:

$$v_o = r_{mean} \times \omega \quad (14)$$

where:

v_o – peripheral speed (m/s)

r_{mean} – mean radius of the active part of a disc (m)

ω – angular velocity of the rotating disk (1/s)

The outlined analysis of the forces and the speed (acceleration) of the particles (Fig. 2) is based on the assumption of their movement along the tangents which form a constant angle with the vectors of the curve (the path trajectory). This curve, whose radius r grows exponentially as the angle increases, is the logarithmic spiral.

The logarithmic spiral, being a trajectory of the fragments pulverized on the active surfaces of the disc crushers, has the following basic properties. The spiral winds around a fixed point. Polar co-

ordinates, in which the pole O and the polar axis x provide the base, are used for its analytical formulation. Each its point in the plane is determined by vector r , i.e. by the distance of a point from the pole and by the angle φ , which is the vector's deviation from the polar axis (SIMMONS 1996; GUZMAN 2003; BANCHOFF, LOVETT 2010).

The logarithmic spiral is defined by the polar (Torricelli) equation (HOLLIDAY-DARR 1998; GUZMAN 2003; BANCHOFF, LOVETT 2010):

$$r = a \times e^{b\varphi} \quad (15)$$

where:

r – logarithmic spiral vector length, i.e. distance of a point from the pole (m)

a, b – logarithmic spiral constants (–)

e – base of natural logarithms (–)

φ – angle which is a deviation of a vector from the polar axis ($^\circ$)

It is also true that:

$$\frac{r_2}{r_1} = \frac{a \times e^{b\varphi_2}}{a \times e^{b\varphi_1}} = e^{b\varphi} \quad (16)$$

Table 1. The total length per unit of the logarithmic spiral s with the changing exponent b

| | | | | | | | | | | |
|---------|-------|-----|------|------|------|------|------|-----|------|------|
| b (-) | 0.1 | 0.2 | 0.3 | 0.4 | 0.5 | 0.6 | 0.7 | 0.8 | 0.9 | 1.0 |
| s (m) | 10.05 | 5.1 | 3.48 | 2.69 | 2.15 | 1.94 | 1.74 | 1.6 | 1.49 | 1.41 |

where:

- r_1, r_2 – vectors of a logarithmic spiral, i.e. of the distance of a point from the pole (m)
- a, b – logarithmic spiral constants (-)
- e – base of natural logarithms (-)
- φ_1, φ_2 – angles which is a deviation of a vector from the polar axis (°)

For the construction of a logarithmic spiral (Table 1) it is necessary to define the above mentioned constants a and b , where a determines the beginning of the spiral and b causes the change in the radius (length) of the spiral. The r_p vector lengths form a geometric sequence:

$$a_n = a_1 \times q^{n-1} \tag{17}$$

where:

- a – logarithmic spiral constants (-)
- n – n -th member of geometric sequence (-)
- q – quotient of geometric sequence (-)

The following is valid for the tangent angle γ , formed by a vector and a tangent for a given point ($r_p; \varphi$):

$$\text{tg } \gamma = \frac{r}{\frac{dr}{d\varphi}} \text{ and thus } \gamma = \text{arctg } \frac{r}{\frac{dr}{d\varphi}} = \text{arctg } \frac{1}{b} \tag{18 and 19}$$

For $b \rightarrow 0$ is $\frac{1}{b} \rightarrow \infty$ and $\text{arctg } \frac{1}{b} \rightarrow \frac{\pi}{2}$ (20–22)

where:

- γ – angle between the curve tangent and the vector at a point (°)
- r – logarithmic spiral vector length, i.e. distance of a point from the pole (m)
- φ – angles which is a deviation of a vector from the polar axis (°)
- b – logarithmic spiral constants (-)
- π – spiral shape is therefore approaching a circle

The tangent angle γ is at each point of a given spiral the same, because the parameter b is constant.

The total length of the spiral s is finite and it changes in a computing relationship with a b exponent, that is, exponentially, with the constant

parameter a determining the distance of the beginning of the spiral from its pole.

A logarithmic spiral equation expressed parametrically:

$$x = r \times \cos t = a \times e^{bt} \times \cos t \tag{23}$$

$$y = r \times \sin t = a \times e^{bt} \times \sin t \tag{24}$$

where:

- x, y, t – parameters of the logarithmic spiral (-)
- r – logarithmic spiral vector length, i.e. distance of a point from the pole (m)
- a, b – logarithmic spiral constants (-)
- e – base of natural logarithms (-)

The change in the radius (length) of the spiral is expressed by the derivation:

$$\frac{dr}{d\varphi} = a \times b \times e^{b\varphi} = b \times r \tag{25 and 26}$$

where:

- r – logarithmic spiral vector length, i.e. distance of a point from the pole (m)
- φ – angle which is a deviation of a vector from the polar axis (°)
- a, b – logarithmic spiral constants (-)
- e – base of natural logarithms (-)

The length of the logarithmic spiral can be determined when we choose any point A at a distance r_p from the spiral's pole, whose position is given by the polar coordinates r and φ . The length of the spiral is determined from its beginning to the point A by using the relationship (GUZMAN 2003; BANCHOFF, LOVETT 2010):

$$s = \int_0^{\varphi} \sqrt{(\dot{x})^2 + (\dot{y})^2} dt \tag{27}$$

where:

- s – length of a logarithmic spiral (m)
- \dot{x}, \dot{y}, t – parameters of the logarithmic spiral (-)

by integration over the entire curve.

If we consider the parameter t to be time then

$$\sqrt{(\dot{x})^2 + (\dot{y})^2}$$

expresses the size of the instantaneous velocity of the movement and it is therefore possible to state:

$$s = \int_{\alpha}^{\beta} v(t) dt \quad (28)$$

where:

- s – length of a logarithmic spiral (m)
- α, β – angles defining the points of a logarithmic spiral in determining its length (°)
- v – instantaneous velocity (m/s)
- t – time (s)

First, the derivation of parametric equations has to be stipulated:

$$\dot{x} = a \times b \times e^{bt} \times \cos t - a \times e^{bt} \times \sin t \quad (29)$$

$$\dot{y} = a \times b \times e^{bt} \times \sin t + a \times e^{bt} \times \cos t \quad (30)$$

where:

- \dot{x}, \dot{y}, t – parameters of the logarithmic spiral (–)
- a, b – logarithmic spiral constants (–)
- e – base of natural logarithms (–)

then the following has to be calculated

$$(\dot{x})^2 + (\dot{y})^2 = (a \times b \times e^{bt})^2 + (a \times e^{bt})^2 = a^2 \times e^{2bt} \times (b^2 + 1) \quad (31)$$

where:

- \dot{x}, \dot{y}, t – parameters of the logarithmic spiral (–)
- a, b – logarithmic spiral constants (–)
- e – base of natural logarithms (–)

RESULTS AND DISCUSSION

In general, the following applies for the length of the element of the curve:

$$(ds)^2 = (dx)^2 + (dy)^2 \quad (32)$$

where:

- s – length of a logarithmic spiral (m)
- \dot{x}, \dot{y} – parameters of the logarithmic spiral (–)

Therefore, after substitution it will be:

$$(ds)^2 = [(\dot{x})^2 + (\dot{y})^2] (dt)^2 \quad (33)$$

where:

- s – length of a logarithmic spiral (m)
- \dot{x}, \dot{y}, t – parameters of the logarithmic spiral (–)

and then the differential of the arc of the curve will be given by the relationship:

$$ds = \sqrt{(\dot{x})^2 + (\dot{y})^2} dt \quad (34)$$

where:

- s – length of a logarithmic spiral (m)
- \dot{x}, \dot{y}, t – parameters of the logarithmic spiral (–)

And the total length will be determined by integration over the entire logarithmic curve, as already shown above (GUZMAN 2003; BANCHOFF, LOVETT 2010):

$$s = \int_0^{\vartheta} \sqrt{(\dot{x})^2 + (\dot{y})^2} dt = \int_0^{\vartheta} a \times e^{bt} \sqrt{b^2 + 1} dt = \frac{a \times e^{b\vartheta} \times \sqrt{b^2 + 1}}{b} = \frac{\sqrt{b^2 + 1}}{b} \times r \quad (35 \text{ and } 36)$$

where:

- s – length of a logarithmic spiral (m)
- \dot{x}, \dot{y}, t – parameters of the logarithmic spiral (–)
- e – base of natural logarithms (–)
- r – logarithmic spiral vector length, i.e. distance of a point from the pole (m)

Increasing the efficiency of separating processes still appears to be an ongoing task. Theoretical analysis of energy requirements of disintegration processes must continue to be verified experimentally. Experiments carried out on the machines used in factory plants cannot provide sufficiently accurate and therefore reproducible results. The presented theory of motion of particles and their fragments on active disc surfaces and the resulting relationships and conclusions have already been preliminarily confronted with laboratory experiments. For this purpose, a measuring apparatus capable of determining the relationships between the above described variables with very good accuracy was assembled in the laboratory of the Department of Technological Equipment of Buildings, Technical Faculty, Czech University of Life Sciences Prague, using an upgraded test stations dynamometer DS 546-4 /V (MEZ a.s., Vsetín, Czech Republic).

CONCLUSION

So far, the measurements and obtained partial results have provided preliminary confirmation of the good efficiency of the separating shear process that takes place in disc mills and also have indicated a corresponding agreement with the presented theoretical assumptions. A more detailed presenta-

tion of the results of laboratory experiments carried out so far on disc machines is beyond the intended scope intention of the authors, as conceived in this publication.

References

- BANCHOFF F.T., LOVETT T.S., 2013. Differential Geometry of Curves and Surfaces. Wellesley, A.K. Peters Ltd.: 200.
- FEYNMAN R.P., LEIGHTON B.R., SANDS M., 2011. The Feynman Lectures on Physics, Boxed Set: The New Millennium Edition. 1st Ed. New York, Basic Books: 552.
- GUZMAN A., 2003. Derivatives and Integrals of Multivariable Functions. 1st Ed. Boston, Birkhäuser: 329.
- HOLLIDAY-DARR K.A., 1998. Applied Descriptive Geometry. 2nd Ed. Independence, Delmar Cengage Learning: 416.
- SIMMONS G., 1996. Calculus With Analytic Geometry. 2nd Ed. McGraw-Hill Science/Engineering/Math: 887.
- ZUEVA G.A., PADOKHIN V.A., DITL P., 2010. Stochastic models of solid particles grinding. Acta Polytechnica, 50: 70–75.

Received for publication May 25, 2012

Accepted after corrections December 10, 2012

Corresponding author:

Ing. PETR VACULÍK, Ph.D., Czech University of Life Sciences Prague, Faculty of Engineering,
Department of Technological Equipment of Buildings, Kamýcká 129, 165 21 Prague 6-Suchdol, Czech Republic
phone: + 420 224 383 192, e-mail: vaculik@tf.czu.cz
