

# Long-term Dentofacial Changes in Chinese Obstructive Sleep Apnea Patients after Treatment with a Mandibular Advancement Device

H. M. Hou<sup>a</sup>; K. Sam<sup>b</sup>; U. Hägg<sup>c</sup>; A. B. M. Rabie<sup>d</sup>; M. Bendeus<sup>e</sup>; L. Y. C. Yam<sup>f</sup>; M. S. Ip<sup>g</sup>

**Abstract:** The objective of this study was to evaluate long-term dentofacial changes in Chinese obstructive sleep apnea (OSA) patients treated with a mandibular advancement device (MAD). Lateral cephalograms in natural head posture were obtained from 67 consecutive OSA patients (mean age = 46.9 ± 8.9 years) treated with an MAD. The cephalograms were obtained at start of treatment (T0), after 1 year (T1), 2 years (T2), and 3 years (T3) of treatment. The lateral cephalograms were digitized twice, and the average of two readings was used for statistical analyses. Small, but statistically significant changes occurred in some dentofacial variables. The lower anterior facial height steadily increased during the observation period, and this increase was significant for the T0–T1 and T1–T2 periods and marginally significant for the T2–T3 period. A significant increase in the mandibular plane angle was observed during the T0–T1 and T2–T3 periods only. Significant reductions in the overjet and overbite were observed for the T0–T1 period but not thereafter. Statistically significant dentofacial changes were observed in this study, but they were of small magnitude. The overjet and overbite changes observed mainly occurred at the initial stage of treatment. (*Angle Orthod* 2005;76:432–440.)

**Key Words:** Obstructive sleep apnea; Cephalometrics; Mandibular advancement device; Side effects

---

<sup>a</sup> Master's student in Orthodontics, Faculty of Dentistry, The University of Hong Kong, Hong Kong SAR, People's Republic of China.

<sup>b</sup> Part-time Lecturer in Orthodontics, Faculty of Dentistry, The University of Hong Kong, Hong Kong SAR, People's Republic of China.

<sup>c</sup> Professor in Orthodontics, Faculty of Dentistry, The University of Hong Kong, Hong Kong SAR, People's Republic of China.

<sup>d</sup> Professor in Orthodontics, Faculty of Dentistry, The University of Hong Kong, Hong Kong SAR, People's Republic of China.

<sup>e</sup> Assistant Professor in Orthodontics, Faculty of Dentistry, The University of Hong Kong, Hong Kong SAR, People's Republic of China

<sup>f</sup> Medical Doctor, Department of Medicine, Pamela Youde Metherole Eastern Hospital, Hong Kong SAR, People's Republic of China.

<sup>g</sup> Chair and Professor in Medicine, Faculty of Medicine, The University of Hong Kong, Queen Mary Hospital, Hong Kong SAR, People's Republic of China.

Corresponding author: U. Hägg, Orthodontics, Faculty of Dentistry, The University of Hong Kong, Prince Philip Dental Hospital, 34 Hospital Road, Hong Kong SAR, People's Republic of China  
(e-mail: euohagg@hkusua.hku.hk)

Accepted: May 2005. Submitted: March 2005.

© 2005 by The EH Angle Education and Research Foundation, Inc.

## INTRODUCTION

Nasal continuous positive airway pressure (NCPAP) therapy is a well-established, widely used nonsurgical treatment option for obstructive sleep apnea (OSA) patients. Other available nonsurgical treatment options for OSA include conservative treatment options (eg, losing weight), oral devices, such as mandibular advancement devices (MADs), and pharmacotherapy.<sup>1,2</sup>

The purpose of MADs is to increase the size of the pharyngeal airway or otherwise reduce its collapsibility and cause forward movement of the tongue.<sup>3–6</sup> Although side effects frequently have been reported with MAD therapy, they were usually mild and acceptable, and most symptoms subsided when treatment was continued.<sup>7–9</sup> Common complaints in connection with MAD treatment include dryness of lips and throat, excessive or increased salivation, a slight tenderness in the teeth and jaws during the initial period of use, and a brief, transient discomfort after awakening.<sup>9–13</sup>

The MAD therapy has also been reported to alter the occlusion and reduce the overjet and overbite.<sup>7,9,14–16</sup> Other dentofacial changes associated with long-term treatment with MADs include alterations in the upper incisal angulation, mandibular posture, and anterior facial height.<sup>7,16–19</sup> Although such dental

side effects have occurred in a significant proportion of patients using MADs, in most cases the side effects were minor, and their inconvenience must be balanced against the beneficial results when MADs are used to treat OSA patients.<sup>9</sup>

Very few reports have been made on long-term follow-up after MAD treatment for OSA patients, and most of these are based on Caucasian samples.<sup>7,15-20</sup> The aim of this study was to evaluate long-term dentofacial changes in Chinese OSA patients treated with MAD.

**MATERIALS AND METHODS**

The subjects for inclusion in this study were (1) patients with mild to moderate OSA; apnea-hypopnea index (AHI): 5 to 30 episode/hour) with symptoms of excessive daytime sleepiness and (2) patients with severe OSA (AHI > 30 episode/hour) who declined or could not tolerate NCPAP treatment. Patients were excluded from the study if they had either (1) insufficiently healthy teeth for MAD retention (based on the clinical assessment by the only orthodontist, who carried out the treatment in this study), (2) active periodontal disease, (3) a history or presence of temporomandibular joint (TMJ) pain or trismus, or both, or (4) obvious anatomic and pathologic airway obstruction. Patients with OSA problems secondary to endocrine diseases such as acromegaly and unstable medical disease were also excluded.

A total of 151 consecutive patients (123 males and 28 females) from a pool of 196 referred OSA patients (156 males and 40 females) fulfilled the inclusion criteria and were considered suitable subjects for MAD treatment. The patients' OSA problems were confirmed with overnight polysomnography studies.

The dropouts were 59 males (48% of the total number of male OSA patients) and nine females (32% of the total number of female OSA patients). The follow-up profile of the sample is summarized in Figure 1. Of the 59 dropout cases in the male sample, four patients were not issued MADs either because contact was lost or because the patients were no longer interested after the baseline records had been taken. The reasons for the other dropout cases are outlined in Table 1. In addition, 16 patients (14 males and two females) who are still undergoing MAD treatment were excluded from the final analyses because they had not undergone treatment for 12 months.

A total of 25 male and two female patients received MAD treatment but subsequently failed to keep their recall appointments. Patients with compliance of less than four days per week (12 males and two females) were also excluded from the study. A total of 10 male and three female patients failed to use the MADs for

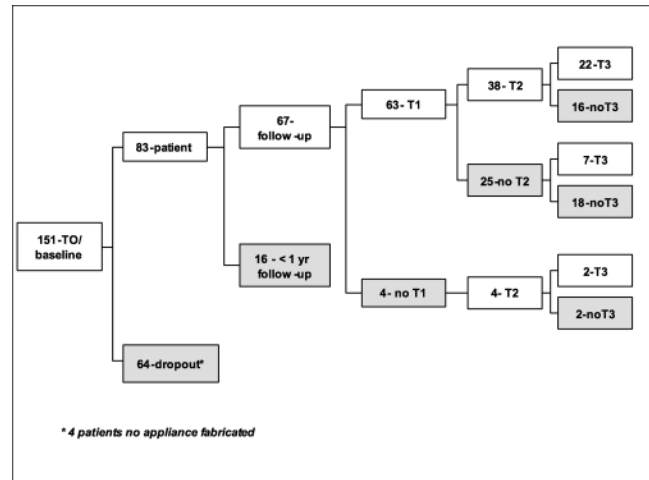

1(a)

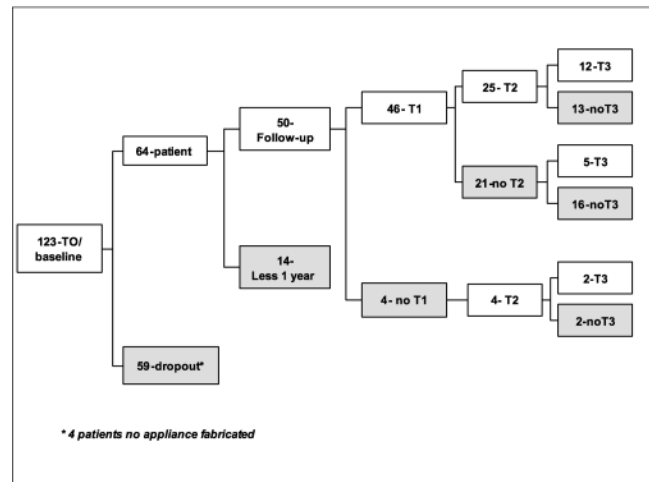

1(b)

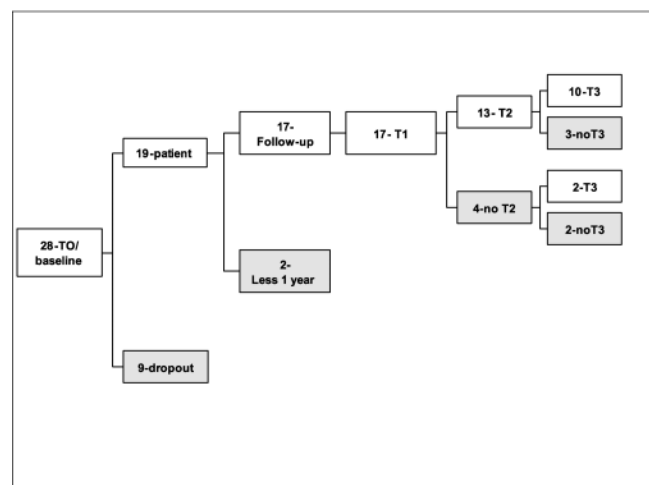

1(c)

**FIGURE 1.** Profile of the obstructive sleep apnea sample—(a) combined male and female, (b) male, and (c) female.

**TABLE 1.** Dropout Reasons for 59/123 Male and 9/28 Female OSA Patients<sup>a</sup>

Reasons	Male OSA Patients n	Female OSA Patients n
Fail follow-up appointment	25	2
Poor compliance	12	2
Failed to use MAD:	10	3
<i>TMJ pain</i>	(1)	(1)
<i>neck pain</i>	(2)	(0)
<i>tooth pain</i>	(2)	(0)
<i>dry mouth</i>	(1)	(0)
<i>choking</i>	(1)	(0)
<i>gastric reflex</i>	(1)	(0)
<i>pituitary tumor</i>	(0)	(1)
<i>cannot adapt</i>	(2)	(1)
Ineffective/increase AHI	4	2
Successful weight reduction	2	0
Lost appliance	1	0
Emigrated	1	0
No appliance fabricated	4	0
Total	59	9

<sup>a</sup> OSA indicates obstructive sleep apnea; MAD, mandibular advancement device; TMJ, temporomandibular joint; AHI, apnea-hypopnea index.

one reason or another (details are shown in Table 1). One patient was diagnosed with a pituitary tumor after she began MAD treatment and was later considered not suitable for MAD treatment.

A total of four male and two female patients had increased AHI after using MADs and were later referred for other treatment options. Two male patients later discontinued MAD treatment because their OSA problem improved after they lost weight. One male patient lost his appliance and did not wish to pay for a replacement, and one male patient emigrated from Hong Kong.

The investigated sample consisted of 67 consecutively treated patients (50 males and 17 females, mean age = 46.9 ± 8.9 years at T0) with at least 1-year

follow-up (T0–T1 group) and at least 4 days per week compliance in using the MAD. The sample size, age, and follow-up periods of this group are summarized in Table 2. Forty of these patients (26 males and 14 females, 60% of the total) had a follow-up from year 1 (T1) to year 2 (T2) (T1–T2 group). Twenty-four patients (14 males and 10 females, 36% of the total) had a follow-up from year 2 (T2) to year 3 (T3) (T2–T3 group). Forty-three patients (29 males and 14 females, 79%) had a 2-year follow-up (T0–T2 group), and 30 patients (19 males and 11 females, 30%) had a 3-year follow-up (T0–T3 group).

### Cephalometric radiograph and statistical analysis

Pretreatment and annual follow-up lateral cephalometric radiographs were obtained with the patients standing upright with a natural head posture.<sup>21</sup> The cephalometric landmarks and measurements used in this study are outlined in Figure 2 and Table 3.

The same operator digitized the lateral cephalometric radiographs twice using the CASOS (Computer Assisted Simulation System for Orthognathic Surgery) computer software. The first and second tracings were carried out at an interval of at least 2 weeks, and the mean values were used for statistical analyses using the SPSS 11.0 package. Test for statistical significance was performed with a paired sample Student's *t*-test. *P*-values of less than .05 were considered significant.

### Method error

Method errors were determined using the formula  $Se = \sqrt{(\sum d^2/2n)}$ , where  $\sum d^2$  is the sum of the squared differences between pairs of measurements and *n*, the number of double measurements. For the linear measurements, the method error determined was 0.5 mm

**TABLE 2.** Sample Size, Age, and Follow-up Periods in OSA Patients Who Have Been Followed 1 to 3 Years

Age (yr)	Age at T0 (T0 Group)			Age at T1 (T0–T1 Group)			Age at T2 (T1–T2 Group)			Age at T3 (T2–T3 Group)			Age at T2 (T0–T2 Group)			Age at T3 (T0–T3 Group)		
	M	F	Total	M	F	Total	M	F	Total	M	F	Total	M	F	Total	M	F	Total
n	50	17	67	47	17	64	26	14	40	14	10	24	29	14	43	19	11	30
Mean	46.6	47.9	46.9	47.8	48.9	48.1	47.4	49.4	48.1	48.3	50.5	49.2	47.3	49.4	48.0	48.7	51.0	49.6
SD	9.66	6.15	8.88	9.91	6.13	9.03	9.26	6.53	8.38	9.49	7.35	8.56	8.86	6.53	8.15	8.90	7.14	8.24
Minimum	20.5	36.8	20.5	21.8	38.0	21.8	22.6	38.9	22.6	36.6	39.7	36.6	22.6	38.9	22.6	36.6	39.7	36.6
Maximum	71.4	59.6	71.4	72.7	60.5	72.7	65.6	62.0	65.6	67.1	62.7	67.1	65.6	62.0	65.6	67.1	62.7	67.1
Follow-up period (yr)	T0–T1			T1–T2			T2–T3			T0–T2			T0–T3					
n	64			40			24			43			30					
Mean	1.0			1.0			0.9			2.0			3.0					
SD	0.16			0.25			0.25			0.22			0.21					
Minimum	0.7			0.5			0.5			1.6			2.5					
Maximum	1.5			1.6			1.4			2.6			3.6					

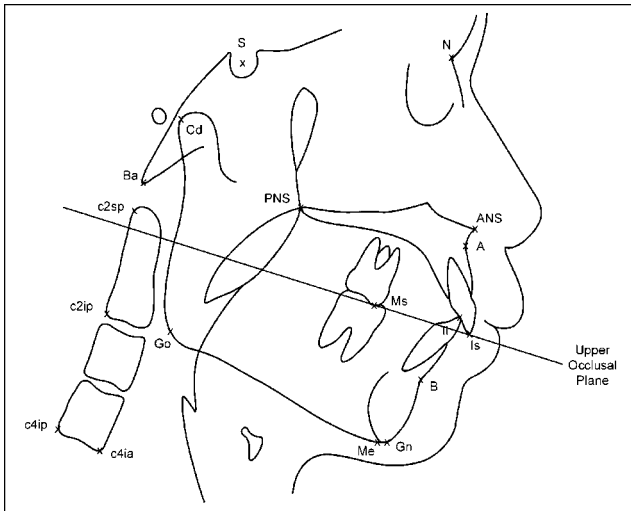

2 (a)

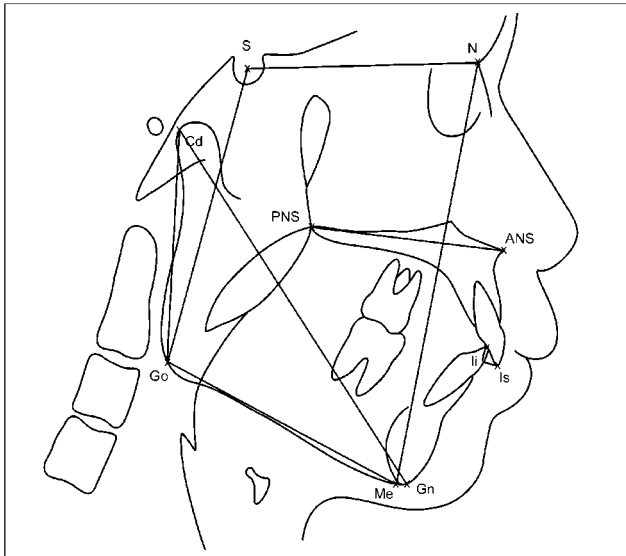

2 (b)

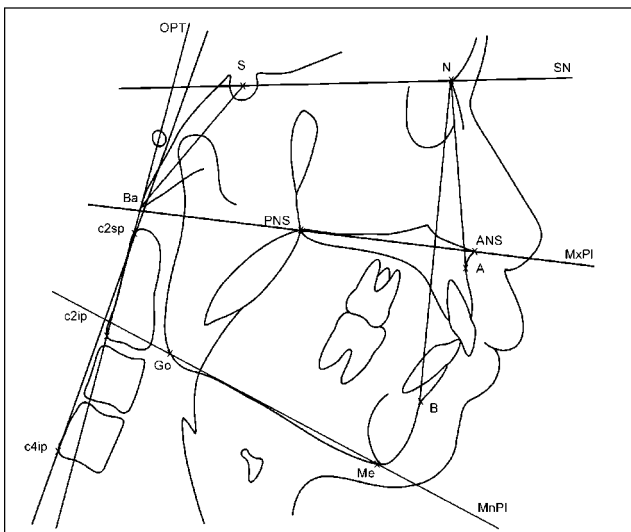

2 (c)

( $P < .4$ ) and  $0.5^\circ$  ( $P < .6$ ) for the angular measurements. These errors were both statistically insignificant.

**Appliance description and design**

The MAD used in this study was a modified Harvold monobloc type of functional appliance (Figure 3). The MAD was custom-made for individual patients using dental acrylic. Bite registration for the MAD followed the method proposed by Bonham et al.<sup>22</sup> The patient was instructed to open and protrude the mandible as far as possible, then relax and retract the mandible slowly until the most protrusive position compatible with comfort was achieved. After the patient was able to reproduce this position easily, a wax bite was obtained with a softened wax bite wafer. Where necessary, the MAD was sectioned and a new jaw relationship was taken. Usually, MAD sectioning was carried out if TMJ fatigue or soreness developed. In such cases, a more comfortable and less protrusive jaw relationship was obtained. In some cases, further advancement was provided if the initial amount of advancement failed to reduce the patient's apnea or hypopnea.

Several characteristics of the MAD deserve mention. It was designed to be retained by incorporating the Adams' clasp and the labial bow. Half capping of posterior teeth and incisal capping of the MAD would prevent/minimize unwanted tooth movement. The lingually extended mandibular flange would guide the mandible forward if the mouth opened and MAD displaced during sleep. Finally, air holes were prepared for mouth breathing.

**RESULTS**

The cephalometric findings at the 1-year, 2-year, and 3-year follow-ups are summarized in Table 4 and Figure 4. The mandibular plane angulation in relation to the anterior skull base (MnPI/SN) showed significant increases during the first year (T0-T1) and third year (T2-T3) observations, but little change was noted during the second year (T1-T2). The total average increase of the MnPI/SN over the 3 years was  $0.3^\circ$  ( $P < .01$ ).

The total anterior facial height (TAFH) increased steadily over the 3 years of observation (0.7 mm;  $P < .001$ ) because of the increase in the lower anterior facial height (LAFH). The increase of LAFH was statis-

←

**FIGURE 2.** (a) Cephalometric landmarks, (b) linear measurement, and (c) angular measurement used in this study.

**TABLE 3.** Cephalometric Landmarks and Measurements Used in Figure 2

Variables	Definition
<b>Landmark</b>	
S	Center of the sella turcica.
N	Nasion, the deepest point in the concavity of nasofrontal suture.
Ba	Basion, the most inferior point on the anterior margin of foramen magnum.
ANS	Anterior nasal spine.
PNS	Posterior nasal spine.
A	A point, the deepest point in the concavity of the anterior maxilla between the anterior nasal spine and the alveolar crest.
B	B point, the deepest point in the concavity of the anterior mandible between the alveolar crest and the pogonion.
Is	Upper incisor tip.
li	Lower incisor tip.
Ms	Mesial buccal cusp tip of upper first molar.
Cd	Condylion, the most posterosuperior point of the condylar head.
Go	Gonion, the most posteroinferior point on the angle of the mandible.
Gn	Gnathion, the most anteroinferior point on the bony chin.
Me	Menton, the most inferior point on the body chin.
c2sp	The most superior posterior point of second cervical vertebra.
c2ip	The most inferior posterior point of second cervical vertebra.
c4ia	The most inferior anterior point of the fourth cervical vertebra.
c4ip	The most inferior posterior point of the fourth cervical vertebra.
MnPI	Mandibular plane, line joining Me and Go.
MxPI	Maxillary plane, line joining PNS and ANS.
Upper occlusal plane	Line joining the Is and Ms (take the second molar if the first molar is missing and take the premolar if both molars are missing).
OPT	Odontoid process tangent, line joining c2sp and c2ip.
<b>Cranio-cervical extension</b>	
OPT-SN (°)	The angle between the OPT and SN line.
c2sp-c4ip-SN (°)	The angle between the c2sp-c4ip line and SN line.
<b>Craniofacial structures</b>	
NSBa (°)	Skull base angle, angle between Nasion-Sella (N-S) line and Sella-Basion (S-Ba).
SNA (°)	The angle between Sella-Nasion (S-N) line and Nasion-A (N-A) line.
SNB (°)	The angle between Sella-Nasion (S-N) line and Nasion-B (N-B) line.
ANB (°)	The angle between Nasion-A (N-A) line and Nasion-B (N-B) line.
MnPI/SN (°)	Mandibular plane angle, the angle between the MnPI and the S-N line.
MxPI/SN (°)	Maxillary plane angle, the angle between the MxPI and the S-N line.
Overjet (mm)	The distance between the Is and li, parallel to the upper occlusal plane (positive if upper incisor is in front of the lower incisor, negative if lower incisor is in front of the upper incisor).
Overbite (mm)	The distance between Is and li, perpendicular to the upper occlusal plane (positive if there is overlapping, negative if there is open bite).
Upper posterior facial height (UPFH) (mm)	The distance from S to MxPI, along S-Go line.
Lower posterior facial height (LPFH) (mm)	The distance from MxPI to Go, along S-Go line.
Total posterior facial height (TPFH) (mm)	The distance from S to Go.
Upper anterior facial height (UAFH) (mm)	The distance from N to MxPI, along N-Me line.
Lower anterior facial height (LAFH) (mm)	The distance from MxPI to Me, along N-Me line.
Total anterior facial height (TAFH) (mm)	The distance from N to Me.
Mandibular length (mm)	The distance between Cd-Gn.
Ramus length (mm)	The distance between Cd-Go.
Body length (mm)	The distance between Go-Me.
Maxillary length (mm)	The distance between ANS and PNS.
SN length (mm)	The distance between S and N.

tically significant during the first-year (T0–T1) and second-year (T1–T2) follow-up periods only. During the third observation year, the LAFH increased marginally only (0.2 mm;  $P < .08$ ). There were no significant changes in the linear measurements of either the max-

illa or the mandible over the 3-year follow-up. Statistically significant changes in lower posterior facial height (LPFH) (0.6 mm;  $P < .01$ ) and total posterior facial height (TPFH) (0.4 mm;  $P < .05$ ) were observed in the 3-year follow-up (T0–T3) period only. The cran-

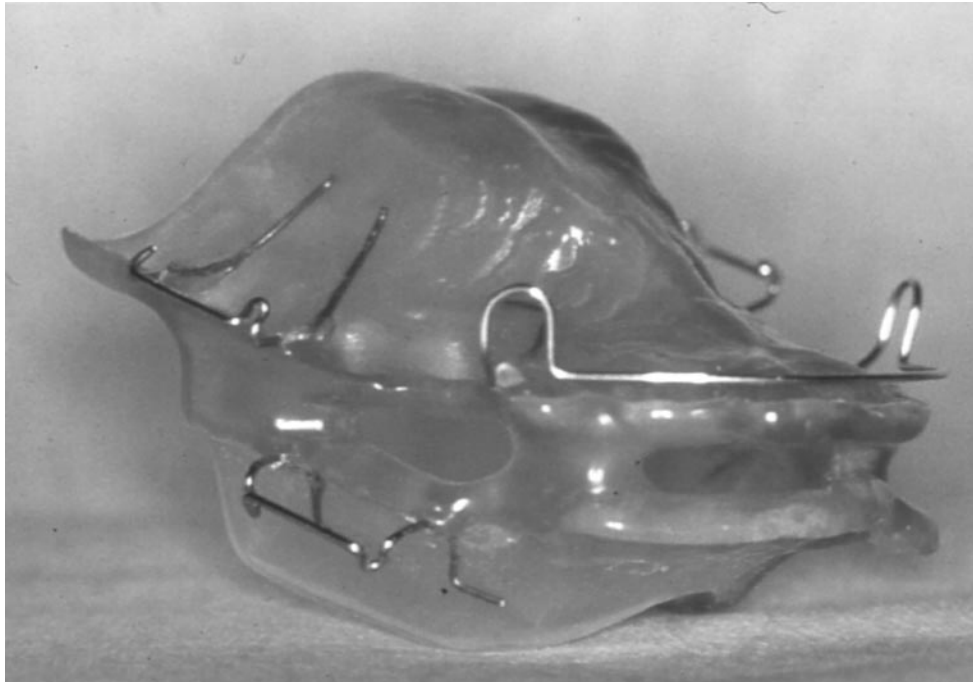

**FIGURE 3.** The modified Harvold monobloc type of functional appliance used in this study.

iocervical extension measurements showed no significant changes during the observation period.

Statistically significant dental changes were observed during the first-year follow-up only. Both the overjet and the overbite showed a statistically significant reduction, but the mean values were small: 0.3 mm ( $P < .01$ ) and 0.2 mm ( $P < .05$ ), respectively. Over the 3-year follow-up (T0–T3), the mean total reductions in the overjet and overbite were 0.8 and 0.6 mm, respectively.

## DISCUSSION

The use of MAD therapy is a well-established option for the treatment of patients with mild or moderate OSA and patients with severe OSA unable to tolerate NCPAP treatment. Because MAD treatment might be a lifelong process, the possible side effects on a patient's dentition, occlusion, and skeletal morphology are of crucial importance in deciding whether this treatment should be used, although it may be a cost-effective option.

Side effects after MAD treatment are common, but in most cases are minor and decrease with the continued use of the device. Pantin et al<sup>9</sup> studied a group of 132 patients who completed questionnaires (a 69% response rate, after recalling patients treated over a 5-year period) and reported that only 10 patients (7.5%) discontinued treatment with MAD because of side effects. Eight patients discontinued treatment because

of temporomandibular joint pain and two because of occlusal changes.

Lateral cephalometric radiographs were used in this study to evaluate possible dentofacial changes associated with long-term treatment with MAD in OSA patients. Many authors have used cephalometry as an adjunctive procedure to assess craniofacial patterns associated with OSA syndrome.<sup>23–28</sup>

The findings of this study show that treatment of OSA with MAD may cause significant changes both dentally and skeletally (Table 4). Reduction occurred gradually in the overjet ( $-0.8$  mm;  $P < .001$ ) and overbite ( $-0.6$  mm;  $P < .01$ ) after 3 years of treatment with MAD, but the reduction over a 1-year period was only significant in the first year. According to Pantin et al,<sup>9</sup> the proportion of patients developing occlusal changes increased with the length of use of the device over the first 2 years and remained relatively constant thereafter. They suggested that the period of greatest vulnerability was within the first 2 years of treatment.

The overjet and overbite reduction observed in this study have also been reported in previous studies.<sup>7,15,16,19</sup> The reduction might be related to the effect of the MAD, which acts like a functional appliance.<sup>29</sup> Retroclination of the upper incisors and proclination of the lower incisors are reported dental side effects of functional appliances, which contribute to the reduction of the overjet and overbite.<sup>30–32</sup> However, the degree of overjet and overbite reduction observed in this

**TABLE 4.** Cephalometric Findings in OSA (obstructive sleep apnea) Patients Treated With MAD (mandibular advancement device) at One-year (T1), Two-year (T2), and Three-year (T3) Follow-ups<sup>a</sup>

Variable	Mean changes T0–T1		Mean changes T1–T2		Mean changes T2–T3		Mean changes T0–T2		Mean changes T0–T3	
	Mean	SD	Mean	SD	Mean	SD	Mean	SD	Mean	SD
Cranio-cervical extension measurement (°)										
OPT-SN	-0.1	4.23	0.3	4.37	-0.3	3.61	0.4	3.77	1.1	4.41
c2sp.c4ip-SN	0.0	4.15	0.3	4.64	0.0	3.62	0.5	3.69	1.2	4.56
Craniofacial angular measurement (°)										
NSBa	0.0	0.54	0.0	0.45	-0.1	0.48	0.1	0.62	0.0	0.53
SNA	0.0	0.53	0.0	0.75	0.1	0.60	0.0	0.73	0.0	0.65
SNB	-0.1	0.56	0.1	0.58	-0.1	0.52	0.0	0.70	-0.2	0.56
ANB	0.1	0.58	-0.1	0.56	0.2	0.55	-0.1	0.48	0.1	0.58
MnPI/SN	0.2*	0.54	0.1	0.53	0.3*	0.53	0.2*	0.60	0.3**	0.56
MxPI/SN	0.0	0.47	-0.1	0.85	0.1	0.61	-0.1	0.88	0.1	0.62
Craniofacial linear measurement (mm)										
Md length	0.1	0.78	0.0	0.59	0.0	0.59	0.2	0.61	0.2	0.79
Ramus length	-0.1	0.68	-0.1	0.90	-0.1	0.65	-0.1	0.89	0.1	0.79
Body length	0.0	0.61	0.1	0.65	0.0	0.62	0.1	0.75	0.0	0.52
Mx length	0.1	0.67	0.0	0.80	0.0	0.49	0.2	0.77	0.0	0.63
SN length	0.1	0.44	-0.1	0.45	0.0	0.45	0.1	0.40	0.1	0.31
Facial height measurement (mm)										
UAFH	0.0	0.51	-0.2	0.64	0.1	0.39	-0.1	0.74	0.0	0.47
LAFH	0.2*	0.67	0.5**	0.85	0.2	0.59	0.6***	0.93	0.8***	0.89
TAFH	0.2**	0.63	0.3*	0.78	0.3**	0.54	0.5**	0.95	0.7***	0.88
UPFH	0.0	0.45	0.0	0.74	0.0	0.68	0.0	0.80	-0.2	0.66
LPFH	0.0	0.88	0.1	1.07	0.0	0.76	0.3	1.13	0.6**	1.01
TPFH	0.0	0.74	0.1	0.87	0.1	0.83	0.2	0.88	0.4*	0.92
Dental measurement (mm)										
Overjet	-0.3*	0.84	-0.2	0.75	-0.1	0.51	-0.5**	0.91	-0.8***	1.16
Overbite	-0.2**	0.53	-0.2	0.69	-0.2	0.58	-0.3*	0.79	-0.6**	0.98

<sup>a</sup> UAFH indicates upper anterior facial height; LAFH, lower anterior facial height; TAFH, total anterior facial height; UPFH, upper posterior facial height; LPFH, lower posterior facial height; TPFH, total posterior facial height.

\*  $P < .05$ ; \*\*  $P < .01$ , \*\*\*  $P < .001$ .

study was less than one mm over the entire 3-year follow-up period.

The increase in LAFH observed in this study was also expressed as a small but statistically significant increase in the mandibular plane angle (MnPI/SN). A longer follow-up period is needed to determine whether any further changes in these two variables occur. Robertson<sup>18</sup> suggested that the skeletal changes related to an increase in vertical face height could be attributed to a repositioning of the head of the mandibular condyle in the glenoid fossa. However, Bonemark<sup>19</sup> suggested that the downward and forward movement of the mandible might result from a remodeling of the condylar or glenoid fossa and an increase in mandibular length. Dental effects such as molar extrusion (which was not investigated in this study) because of inadequate occlusal coverage from the appliance may cause an increase in the LAFH and MnPI/SN. Further study is needed to investigate the possible factors affecting the LAFH and MnPI/SN.

Two earlier studies<sup>7,17</sup> reported a significant reduc-

tion in the SNB angle. In contrast, no significant change in the SNB angle was observed in this study. The downward and backward rotation movements of the mandible contributed to a small increase in the mandibular plane angle and LAFH but did not produce a significant change in mandibular prognathism (SNB).

Pantin et al<sup>9</sup> reported that dental changes were usually minor and unnoticed by the patients. They suggested that treatment could be continued if there were no unacceptable or progressive symptoms and there was adequate posterior support, provided that changes were monitored regularly. Several studies have reported statistically significant dental and skeletal changes associated with the use of MADs in treating OSA patients. Although conceding that these changes appear to be minor in the short term, they have noted that a longer follow-up period is necessary to enable possible long-term deterioration to be properly evaluated.<sup>7,15–20</sup>

Because of the way previous studies<sup>7,15–20</sup> were designed, it is not possible to directly compare the results

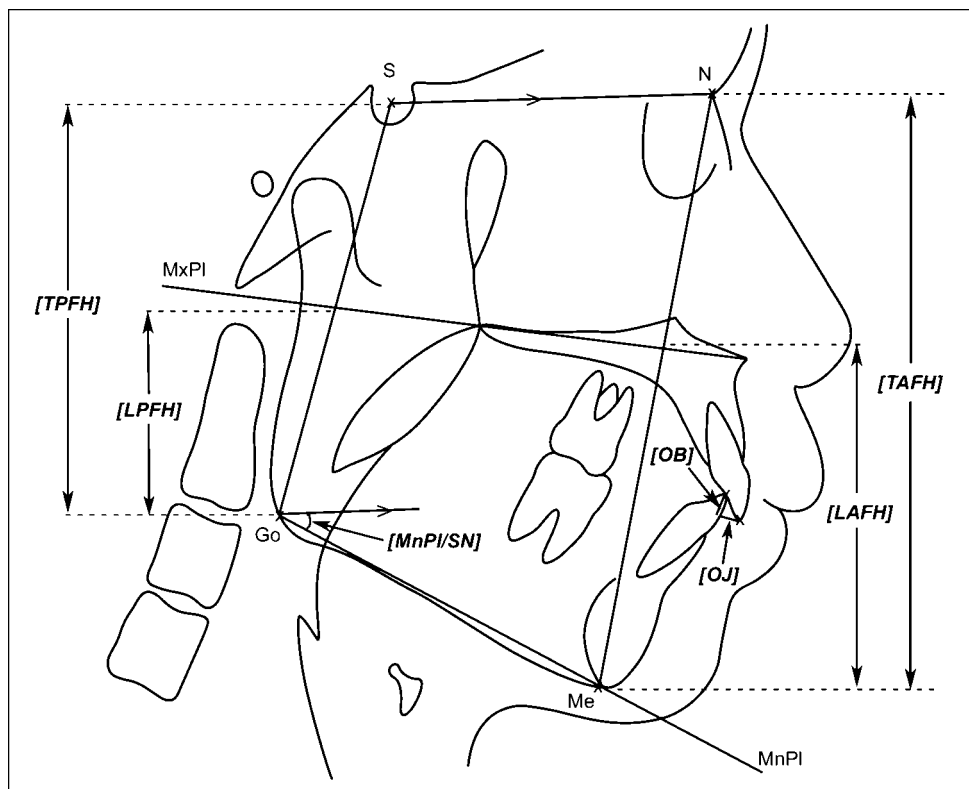

**FIGURE 4.** Statistically significant cephalometric findings (Table 4) in obstructive sleep apnea patients treated with mandibular advancement device at one-year (T1), two-year (T2), and three-year (T3) follow-ups.

of this study with those of its predecessors. An important feature of this study, but not of previous studies,<sup>7,15–20</sup> is its use of yearly evaluations. In one previous study,<sup>18</sup> patients were randomly assigned to 6-month, 12-month, 24-month, and 30-month review groups, but only one lateral cephalometric radiograph was taken for each patient (one baseline and one follow-up lateral cephalometric radiograph).

The yearly review lateral cephalometric radiographs used in this study enabled changes occurring at the early stage of treatment only, gradual changes, and late changes to be distinguished. This allowed a closer evaluation of the pattern of the dentofacial changes. For example, this study noted that the significant reduction in overjet and overbite occurred at the early stage (T0–T1) of treatment but not in the later stages (T1–T2 and T2–T3). On the other hand, the overjet and overbite reduction at the early stage remained statistically significant in the analyses for the 2-year (T0–T2) and 3-year (T0–T3) follow-up periods. Furthermore, some changes were too small to register at annual intervals but showed up over a longer period. For example, the LPPFH and TPFH changes were observed only in 3-year follow-up (T0–T3) but not in the annual evaluations (T0–T1, T1–T2, and T2–T3) or the 2-year follow-up (T0–T2).

## CONCLUSIONS

- Although statistically significant dentofacial changes were observed in this study, they were relatively small.
- Overjet and overbite changes observed mainly occurred at the early stage of treatment.

## REFERENCES

1. Grunstein RR, Hedner J, Grote L. Treatment options for sleep apnoea. *Drugs*. 2001;61:237–251.
2. Goldberg R. Treatment of obstructive sleep apnea, other than with continuous positive airway pressure. *Curr Opin Pulm Med*. 2000;6:496–500.
3. Johal A, Battagel JM. Current principles in the management of obstructive sleep apnoea with mandibular advancement appliances. *Br Dent J*. 2001;190:532–536.
4. Lowe AA. Oral appliances for sleep breathing disorder. In: Kryger MH, Roth T, Dement WC, eds. *Principles and Practice of Sleep Medicine*. 3rd ed. Philadelphia, Pa: Saunders; 2000:929–939.
5. Ryan CF, Love LL, Peat D, Fleetham JA, Lowe AA. Mandibular advancement oral appliance therapy for obstructive sleep apnea: effect on awake caliber of the velopharynx. *Thorax*. 1999;54:972–977.
6. Gale DJ, Sawyer RH, Woodcock A, Stone P, Thompson R, O'Brien K. Do oral appliances enlarge the airway in patients with obstructive sleep apnea? A prospective computerized tomographic study. *Eur J Orthod*. 2000;22:159–168.



7. Fritsch KM, Iseli A, Russi EW, Bloch KE. Side effects of mandibular advancement devices for sleep apnea treatment. *Am J Respir Crit Care Med.* 2001;164:813–818.
8. Lindman R, Bondemark L. A review of oral devices in the treatment of habitual snoring and obstructive sleep apnea. *Swed Dent J.* 2001;25:39–51.
9. Pantin CC, Hillman DR, Tennant M. Dental side effects of an oral device to treat snoring and obstructive sleep apnea. *Sleep.* 1999;22:237–240.
10. O'Sullivan RA, Hillman DR, Mateljan R, Pantin C, Finucane KE. Mandibular advancement splint: an appliance to treat snoring and obstructive sleep apnea. *Am J Respir Crit Care Med.* 1995;151:194–198.
11. Schmidt-Nowara WW, Meade TE, Hays MB. Treatment of snoring and obstructive sleep apnea with a dental orthosis. *Chest.* 1991;99:1378–1385.
12. Ferguson KA, Ono T, Lowe AA, Keenan SP, Fleetham JA. A randomized crossover study of an oral appliance vs nasal-continuous positive airway pressure in the treatment of mild-moderate obstructive sleep apnea. *Chest.* 1996;109:1269–1275.
13. Mehta A, Qian J, Petocz P, Darendeliler MA, Cistulli PA. A randomized, controlled study of a mandibular advancement splint for obstructive sleep apnea. *Am J Respir Crit Care Med.* 2001;163:1457–1461.
14. Bondemark L, Lindman R. Craniomandibular status and function in patients with habitual snoring and obstructive sleep apnea after nocturnal treatment with a mandibular advancement splint: a 2-year follow-up. *Eur J Orthod.* 2000;22:53–60.
15. Marklund M, Franklin KA, Persson M. Orthodontic side-effects of mandibular advancement devices during treatment of snoring and sleep apnoea. *Eur J Orthod.* 2001;23:135–144.
16. Rose EC, Staats R, Virchow C Jr, Jonas IE. Occlusal and skeletal effects of an oral appliance in the treatment of obstructive sleep apnea. *Chest.* 2002;122:871–877.
17. Fransson AM, Tegelberg A, Svensson BA, Lennartsson B, Isacson G. Influence of mandibular protruding device on airway passages and dentofacial characteristics in obstructive sleep apnea and snoring. *Am J Orthod Dentofacial Orthop.* 2002;122:371–379.
18. Robertson CJ. Dental and skeletal changes associated with long-term mandibular advancement. *Sleep.* 2001;24:531–537.
19. Bondemark L. Does 2 years' nocturnal treatment with a mandibular advancement splint in adult patients with snoring and OSAS cause a change in the posture of the mandible? *Am J Orthod Dentofacial Orthop.* 1999;116:621–628.
20. Ringqvist M, Walker-Engstrom ML, Tegelberg A, Ringqvist I. Dental and skeletal changes after 4 years of obstructive sleep apnea treatment with a mandibular advancement device: a prospective, randomized study. *Am J Orthod Dentofacial Orthop.* 2003;124:53–60.
21. Cooke MS, Wei SH. The reproducibility of natural head posture: a methodological study. *Am J Orthod Dentofacial Orthop.* 1988;93:280–288.
22. Bonham PE, Currier GF, Orr WC, Othman J, Nanda RS. The effect of a modified functional appliance on obstructive sleep apnea. *Am J Orthod Dentofacial Orthop.* 1988;94:384–392.
23. Lyberg T, Krogstad O, Djupesland G. Cephalometric analysis in patients with obstructive sleep apnoea syndrome. I. Skeletal morphology. *J Laryngol Otol.* 1989;103:287–292.
24. Andersson L, Brattstrom V. Cephalometric analysis of permanently snoring patients with and without obstructive sleep apnea syndrome. *Int J Oral Maxillofac Surg.* 1991;20:159–162.
25. Tsuchiya M, Lowe AA, Pae EK, Fleetham JA. Obstructive sleep apnea subtypes by cluster analysis. *Am J Orthod Dentofacial Orthop.* 1992;101:533–542.
26. Lyberg T, Krogstad O, Djupesland G. Cephalometric analysis in patients with obstructive sleep apnoea syndrome: II. Soft tissue morphology. *J Laryngol Otol.* 1989;103:293–297.
27. Lowe AA, Santamaria JD, Fleetham JA, Price C. Facial morphology and obstructive sleep apnea. *Am J Orthod Dentofacial Orthop.* 1986;90:484–491.
28. Tangugsorn V, Skatvedt O, Krogstad O, Lyberg T. Obstructive sleep apnoea: a cephalometric study. Part I. Cervico-craniofacial skeletal morphology. *Eur J Orthod.* 1995;17:45–56.
29. Rakosi T. Treatment of Class II malocclusion. In: Graber TM, Rakosi T, Petrovic AG, eds. *Dentofacial Orthopedics with Functional Appliances.* 2nd ed. St Louis, Mo: Mosby; 1997:417–451.
30. Pancherz H. A cephalometric analysis of skeletal and dental changes contributing to Class II correction in activator treatment. *Am J Orthod.* 1984;85:125–134.
31. Jakobsson SO, Paulin G. The influence of activator treatment on skeletal growth in Angle Class II: 1 cases. A roentgenocephalometric study. *Eur J Orthod.* 1990;12:174–184.
32. Cura N, Sarac M, Ozturk Y, Surmeli N. Orthodontic and orthopedic effects of Activator, Activator-HG combination, and Bass appliances: a comparative study. *Am J Orthod Dentofacial Orthop.* 1996;110:36–45.