

Craniofacial growth differences between low and high MP-SN angle males: a longitudinal study

Alf Tor Karlsen, DDS

Incination of the mandibular plane is an easily recognizable characteristic of human physiognomy. Traditionally, it is also a trait given considerable attention when, through the use of purely clinical criteria, a prediction of facial growth is desired. The steeper the mandibular plane, the greater the vertical growth, and vice versa.

Vertical growth of the face is closely related to mandibular growth rotation. Schudy¹ believed that the inclination of the mandibular plane could be a good indicator of mandibular rotation. A small MP-SN angle would indicate that the mandible had rotated forward, while a large angle would be a sign of backward rotation. Isaacson et al.² gave a similar viewpoint, at least concerning the more ex-

treme variations of the MP-SN angle. Björk³ showed that the lower border of the mandible remodels during growth so that it masks parts of the jaw rotation. According to Skieller, Björk and Linde-Hansen,⁴ the MP-SN angle can explain only about 60% of the variability in mandibular growth rotation.

It is a fact that persons with different mandibular plane inclinations vary also in other morphological characteristics.⁵ To what extent such persons vary concerning craniofacial growth over a certain period of time is less known. In the present study craniofacial growth was followed longitudinally from 6 to 15 years of age in two groups of boys with low and high MP-SN angles. The groups were compared with regard to dimensional changes and

Abstract

Craniofacial growth was followed longitudinally in two groups of boys with low and high MP-SN angles. The purpose was, first, to reveal group differences in dimensional change, and second, to find whether such differences were associated with a group difference in mandibular growth rotation.

Group differences in dimensional change were explained by a difference in matrix rotation of the mandibular corpus, especially in the 6- to 12-year period. In the 12- to 15-year period, matrix rotation was similar in the two groups and so were dimensional changes. Morphologically, dimensional group differences in the 6- to 12-year period were theoretically compatible with the fact that mandibular rotation was clearly more forward in the low angle than in the high angle group. Statistically, dimensional variables with significant group difference were correlated strongly with matrix rotation and, in most cases, non-significantly with intramatrix rotation.

Key Words

Craniofacial growth • Cephalometrics • Longitudinal • Males • MP-SN angles

Submitted: November 1993

Revised and accepted: September 1994

Angle Orthod 1995;65(5):341-350.

Figure 1
Reference points were projected on parallels to the sagittal axis SN' and the vertical axis SNP'. Sagittal distances were read from left to right, vertical distances from top to bottom (Table 2, vv 1-10). Overjet (oj) and overbite (ob) are marked separately.

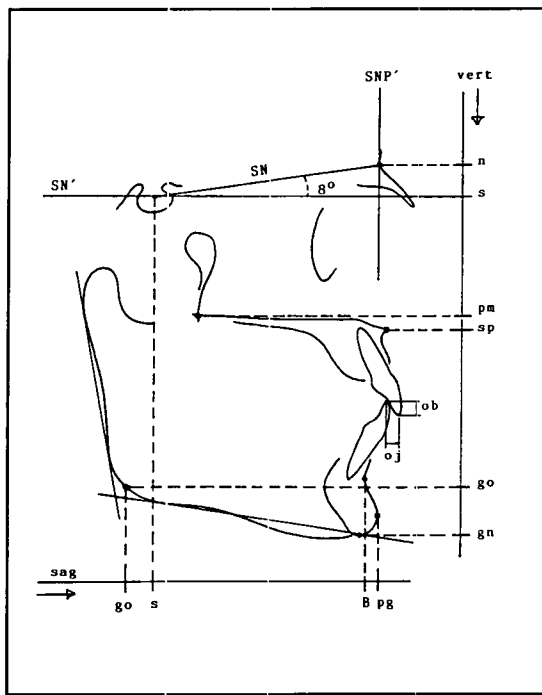

Figure 1

Figure 2
Linear variables within the cranial base and jaws. The variables are numbered according to Table 2 (vv 11-23).

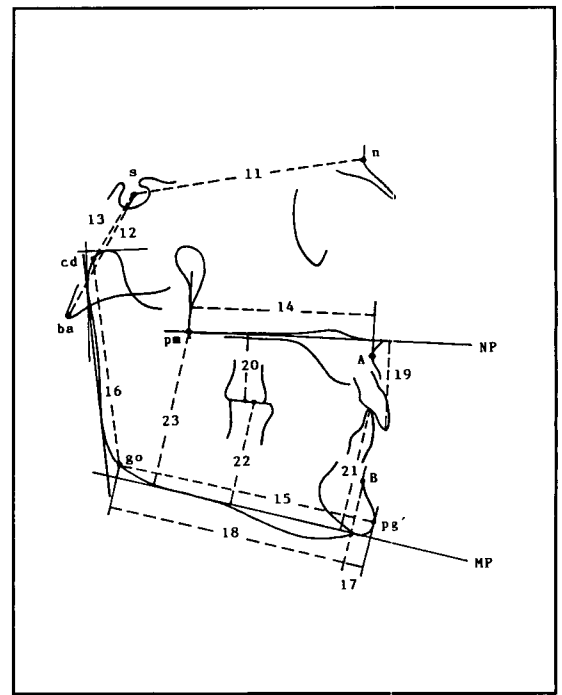

Figure 2

Figure 3
Reference points and lines used when measuring angular variables (Table 2, vv 24-31).

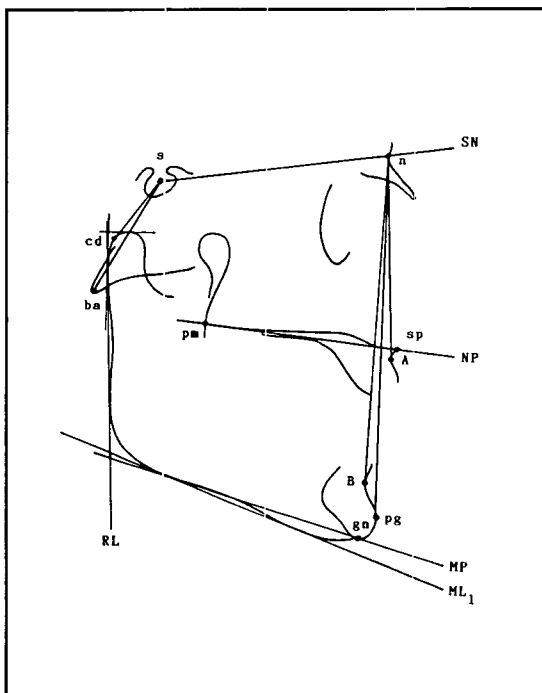

Figure 3

mandibular growth rotation. The purpose was, first, to look for dimensional group differences, and second, to find whether such differences were associated with group differences in mandibular growth rotation.

Materials and methods

The material of the study consisted of records selected from the Oslo Growth Material, University of Oslo Department of Orthodontics.

Each individual was represented with lateral cephalograms taken at 6, 12, and 15 years of age. The aim was to make up two groups of 15 boys with the greatest possible group difference in mandibular plane inclination, measured by the MP-SN angle. A limited number of 6-year-olds with considerable MP-SN variation was found in the archive. Among 12-year-olds the variation was greater. At the selection, therefore, only the MP-SN angle at age 12 was taken into consideration. In order to achieve the desired group size, MP-SN had to be set at 26° or less in the low angle group and 35° or more in the high angle group. The two groups represented the outer limits in the archive regarding the size of the MP-SN angle at 12 years of age. In comparison, Isaacson et al.,² who studied young adolescents with extreme variation in vertical facial growth, stipulated that the MP-SN angle be less than 26° and greater than 38° in the low and high angle groups respectively.

Tanner⁶ believed that the material of a cross-sectional study had to be at least 20 times larger than that of a longitudinal study to give the same degree of precision when evaluating average growth increments. Thus, the material of the present study seemed satisfactory in size and comparable with previous longitudinal studies.⁷

Table 1
Definition of reference points and lines.

<i>Reference points</i>	
A-point	The deepest point on the contour of the maxillary alveolar process, measured in relation to the sagittal axis SN'.
B-point	The deepest point on the contour of the mandibular alveolar process, measured in relation to the sagittal axis SN'.
Basion (ba)	The lowest, most posterior point on the anterior contour of the foramen magnum.
Condylion (cd)	Point on the contour of the condyle obtained by bisecting the angle formed by tangents to the upper and posterior borders of the condyle, the tangents being parallels to the sagittal and vertical axes of the face, respectively.
Gnathion (gn)	The deepest point of the symphysis, measured in relation to the vertical axis SNP'.
Gonion (go)	Point on the contour of the mandible obtained by bisecting the angle between the mandibular plane and the tangent to the posterior border of the mandible.
Incision inferius (ii)	The incisal point of the most prominent mandibular incisor.
Incision superius (is)	The incisal point of the most prominent maxillary central incisor.
L6	At age 6: midpoint of the occlusal surface of the mandibular second deciduous molar; at ages 12 and 15: the corresponding point of the mandibular first permanent molar.
Nasion (n)	Anterior limit of the nasofrontal suture.
Pogonion (pg)	The most prominent point of the symphysis, measured in relation to the sagittal axis SN'.
Pogonion marked (pg')	The most prominent point of the symphysis, measured in relation to the mandibular plane.
Pterygomaxillare (pm)	Point of intersection of hard palate, soft palate, and pterygopalatal fissure.
Sella (s)	Center of sella turcica.
Spinal point (sp)	Apex of the anterior nasal spine.
U6	At age 6: midpoint of the occlusal surface of the maxillary second deciduous molar; at ages 12 and 15: the corresponding point of the maxillary first permanent molar.
<i>Reference lines</i>	
SN Anterior cranial base	The line between sella and nasion.
NP Nasal plane	The line between pterygomaxillare and the spinal point.
MP Mandibular plane	The tangent to the lower border of the mandible through gnathion.
ML ₁ Tangential mandibular line	The tangent to the lower border of the mandible.
RL Ramus line	The tangent to the posterior border of the mandible.

Analysis of dimensional increase and craniofacial morphology

Dimensional increase and absolute craniofacial dimensions were, in some cases, measured along a sagittal or a vertical axis. The sagittal axis was constructed through sella at an angle of 8° to the SN-line and given the designation SN marked (SN'). The vertical axis was perpendicular to SN' through nasion, in the following referred to as SNP marked (SNP'). The

background for choosing this coordinate system is given elsewhere.⁸ A method of measuring craniofacial dimensions in a system with sagittal and vertical axes is well known.⁹

Figure 1 shows how reference points were projected on parallels to the axes SN' and SNP'. Figure 2 illustrates linear variables within the cranial base and jaws. Points and lines used in measurement of angular variables are drawn in Figure 3. Table 1 gives definitions

Table 2
Definition of variables

Distances measured along the sagittal axis SN' (Figure 1)

- | | | |
|----|-----------|--------------------------------------------------------------------------------------------------------------------------------------|
| 1. | B-pg sag | Sagittal distance between B-point and pogonion. An expression of the inclination of the symphysis. |
| 2. | go-s sag | Sagittal distance between gonion and sella. If gonion had a more forward position than sella, the distance was given negative value. |
| 3. | ii-is sag | Overjet. |

Distances measured along the vertical axis SNP' (Figure 1)

- | | | |
|-----|------------|--------------------------------|
| 4. | n-gn vert | Anterior facial height. |
| 5. | n-sp vert | Upper anterior facial height. |
| 6. | sp-gn vert | Lower anterior facial height. |
| 7. | s-go vert | Posterior facial height. |
| 8. | s-pm vert | Upper posterior facial height. |
| 9. | pm-go vert | Lower posterior facial height. |
| 10. | ii-is vert | Overbite. |

Cranial base and jaws - size and proportions (Figure 2)

- | | | |
|-----|--------|-------------------------------------------------------------------------------------------------------------------------------------|
| 11. | s-n | Length of the anterior cranial base. |
| 12. | s-ba | Length of medial cranial base, posterior portion. |
| 13. | s-cd | Length of lateral cranial base, posterior portion. |
| 14. | pm-A | Distance between pterygomaxillare and A-point, measured along the nasal plane (NP). Length of maxillary corpus. |
| 15. | go-pg' | Length of mandibular corpus. |
| 16. | cd-go | Height of mandibular ramus. |
| 17. | B-pg' | Distance between B-point and pogonion marked, measured along the mandibular plane (MP). Length of the mental process. |
| 18. | go-B | Distance between gonion and B-point, measured along the mandibular plane (MP). Length of mandibular corpus less the mental process. |
| 19. | NP-is | Vertical distance between incision superius and the nasal plane (NP). Maxillary incisor height. |
| 20. | NP-U6 | Vertical distance between point U6 and the nasal plane (NP). Maxillary molar height. |
| 21. | ii-MP | Vertical distance between incision inferius and the mandibular plane (MP). Mandibular incisor height. |
| 22. | L6-MP | Vertical distance between point L6 and the mandibular plane (MP). Mandibular molar height. |
| 23. | pm-MP | Vertical distance between pterygomaxillare and the mandibular plane (MP). A measurement of posterior lower facial height. |

Angular variables (Figure 3)

- | | | |
|-----|--------|----------------------------------------|
| 24. | ba-s-n | Medial cranial base angle. |
| 25. | cd-s-n | Lateral cranial base angle. |
| 26. | s-n-A | Maxillary prognathy. |
| 27. | s-n-B | A measurement of mandibular prognathy. |
| 28. | s-n-pg | A measurement of mandibular prognathy. |
| 29. | NP-SN | Nasal plane angle. |
| 30. | MP-SN | Mandibular plane angle. |
| 31. | MP-RL | Jaw angle. |

of reference points and lines. Linear and angular variables are explained in Table 2.

Analysis of mandibular growth rotation

Mandibular growth rotation was analyzed using methods suggested by Björk and Skieller.¹⁰ Accordingly, mandibular rotation was divided into total rotation and its components, matrix rotation, and intramatrix rotation, the latter two being capable of independent rotation.

Matrix rotation expresses the rotation of the soft-tissue covering of the mandible. The bony corpus follows this rotation. Metrically, matrix rotation was defined as the change in inclination of the tangential mandibular line ML_1 (Figure 3) relative to the SN line. Matrix rotation was given a negative sign when the tangential line rotated forward.

Intramatrix rotation refers to the rotation of the mandibular corpus inside the soft-tissue matrix. This rotation is masked by remodeling. In recording intramatrix rotation, a mandibular reference line was drawn on the cephalogram taken at age 6. The line was transferred to subsequent cephalograms after superimposition on stable natural structures in the mandibular corpus. Metrically, intramatrix rotation was defined as the change in inclination of the mandibular reference line relative to the tangential mandibular line ML_1 . The rotation was recorded as negative when the reference line rotated forward. Total mandibular rotation was defined as the sum of matrix rotation and intramatrix rotation.

Reliability

Every lateral cephalogram was traced and measured twice. A tolerance limit of 1 mm and 1° was established for the difference between the first and second observations of linear and angular measurements. If the limit was exceeded, a new tracing and measurement were made. In this manner three observations were available, the most extreme being excluded.¹¹

Statistical analysis

Group differences in dimensional change and mandibular rotation in the 6- to 12-year and 12- to 15-year periods were tested with Student's t-test for independent samples. In order to find the most characteristic differences between the groups, a stepwise discriminant analysis was done for the 6- to 12-year and 12- to 15-year periods, including only significant variables from the t-tests. Finally, a correlation analysis was performed between dimensional and rotational variables. Analyses were done with programs in the statistics package BMDP.¹²

Table 3
Mean and standard deviation for the angle MP-SN at age 12 in the low (n=15) and high (n=15) angle groups.

	MP-SN (°)
Low angles	22.9 ± 2.4
High angles	40.5 ± 3.6

Results

Table 3 shows mean and standard deviation (°) for the MP-SN angle in the low and high angle groups at age 12.

Linear variables

As Table 4 shows, significant group differences in dimensional increase were noted solely for the 6- to 12-year period. As a rule, when a linear variable had its highest absolute value in one group at age 6, it also increased most in that group up to age 12. From 12 to 15 years of age, however, growth progressed more or less alike in the two groups.

In the 6- to 12-year period, some linear variables increased most in the low angle group, while others had their greatest increase with the high angles. The former category included the sagittal distance between B-point and pogonion (variable 1), the length of the lateral cranial base, posterior portion (v 13), the posterior lower facial height (vv 9, 23), as well as the length of the mandibular corpus without the mental process (v 18).

Variables with greater increase in the high angle group were the total anterior and anterior lower facial heights (vv 4, 6), and the incisor height of both jaws (vv 19, 21). One linear variable did not follow the normal growth pattern: At age 6 the mental process (v 17) was longest in the low angle group, but even so, lengthened most with the high angle individuals up to age 12.

Angular variables

As for angular variables, only the MP-SN angle (v 30) and the jaw angle (v 31) developed differently in the groups. Both angles decreased with age. In the 6- to 12-year period, however, the decrease was clearly greatest in the low angle group, where the angles were smallest to begin with. From 12 to 15 years of age the angles decreased about the same in the two groups.

Table 4
Dimensional changes for variables that differed significantly between the low (n=15) and high (n=15) angle groups. Absolute values for the variables are also noted.

Variables	Growth increments		Absolute values		
	6-12 yrs	12-15 yrs	6 yrs	12 yrs	15 yrs
1. B-pg sag (mm)					
Low angles	2.4	1.4	0.5	2.9	4.3
High angles	1.4	1.0	-1.7	-0.4	0.7
P-value	0.0016 ^{xx}	0.24			
4. n-gn vert (mm)					
Low angles	11.1	7.3	95.3	106.4	113.6
High angles	14.6	9.0	101.5	116.1	125.1
P-value	0.0005 ^{xxx}	0.10			
6. sp-gn vert (mm)					
Low angles	4.9	4.0	52.4	57.3	61.3
High angles	8.1	5.6	57.5	65.6	71.2
P-value	0.0001 ^{xxx}	0.065			
9. pm-go vert (mm)					
Low angles	4.8	4.8	30.8	35.6	40.4
High angles	2.8	5.2	25.5	28.3	33.6
P-value	0.007 ^{xx}	0.64			
13. s-cd (mm)					
Low angles	3.9	2.0	22.7	26.5	28.5
High angles	3.0	2.2	20.8	23.7	26.0
P-value	0.009 ^{xx}	0.59			
17. B-pg' (mm)					
Low angles	1.8	1.2	4.9	6.7	7.9
High angles	3.3	1.2	3.9	7.2	8.4
P-value	0.001 ^{xxx}	0.88			
18. go-B (mm)					
Low angles	8.8	4.4	58.4	67.2	71.6
High angles	6.6	3.9	56.9	63.4	67.4
P-value	0.003 ^{xx}	0.57			
19. NP-is (mm)					
Low angles	3.5	0.9	22.6	26.1	27.0
High angles	5.4	1.6	24.8	30.1	31.7
P-value	0.015 ^x	0.063			
21. ii-MP (mm)					
Low angles	3.8	2.5	33.3	37.1	39.6
High angles	5.6	2.7	36.4	42.0	44.7
P-value	0.0003 ^{xxx}	0.73			
23. pm-MP (mm)					
Low angles	5.5	4.9	38.3	43.8	48.7
High angles	3.7	5.4	34.2	37.9	43.3
P-value	0.01 ^{xx}	0.58			
30. MP-SN (°)					
Low angles	-4.4	-2.2	27.3	22.9	20.6
High angles	-1.1	-2.2	41.6	40.5	38.3
P-value	0.0001 ^{xxx}	0.92			
31. MP-RL (°)					
Low angles	-6.9	-3.2	124.9	118.0	114.9
High angles	-3.4	-2.9	138.2	134.8	131.9
P-value	0.0008 ^{xxx}	0.79			

^x P≤0.05, ^{xx} P≤0.01, ^{xxx} P≤0.001, \bar{x} = mean.

Table 5
Mandibular rotation (total rotation, matrix rotation and intramatrix rotation)
in the low (n=15) and high (n=15) angle groups

	Total rot. (°)			Matrix rot. (°)			Intramatrix rot. (°)		
	\bar{x}	Min.	Max.	\bar{x}	Min.	Max.	\bar{x}	Min.	Max.
6-12 yrs									
Low angles	-7.7	-12.5	-3.5	-2.5	-5.3	0.8	-5.3	-9.5	-1.3
High angles	-4.2	-8.5	-0.3	-0.2	-3.0	2.0	-4.0	-7.8	-1.0
P-value	0.0002 ^{xxx}			0.0006 ^{xxx}			0.13		
12-15 yrs									
Low angles	-3.8	-8.3	-1.5	-1.5	-6.3	1.5	-2.2	-4.8	-1.0
High angles	-2.2	-4.3	0.0	-1.8	-5.3	0.0	-0.4	-2.8	2.3
P-value	0.025 ^x			0.64			0.0015 ^{xx}		

Negative values denote forward rotation, positive values denote backward rotation.

^x P≤0.05, ^{xx} P≤0.01, ^{xxx} P≤0.001, \bar{x} = mean.

Mandibular growth rotation

Group comparisons of mandibular growth rotation appear in Table 5. From 6 to 12 years of age, total mandibular rotation was directed forward in both groups, though clearly most with the low angles. The same thing applied to the matrix rotation. Intramatrix rotation was directed forward about equally in the groups.

In the 12- to 15-year period, total rotation was still more forward in the low angle than in the high angle group, but the rotational group difference was less distinct than before. In the high angle group matrix rotation was directed more forward than in the previous period, thus equalling the matrix rotation rate with the low angles. Intramatrix rotation, on the other hand, was almost nonexistent with the high angles between ages 12 and 15.

Discriminant analysis

With regard to craniofacial growth in the 6- to 12-year period, four variables, sp-gn vert (v 6), pm-MP (v 23), B-pg sag (v 1) and B-pg' (v 17) proved the most effective discriminators between the groups. In combination they classified correctly 96.7% of the cases (100% correct for low angle cases and 93.3% correct for high angle cases). In the 12- to 15-year period, effective discriminators were absent. The best discriminator was, surprisingly, intramatrix rotation, which classified 73.3% correctly (80% correct for low angle cases and 66.7% correct for high angle cases).

Correlation analysis

Coefficients of correlations between dimensional change and mandibular growth rotation in the 6- to 12-year period are presented in Table 6. Significant correlations were almost exclusively noted between dimensional change and total rotation and between dimensional change and matrix rotation.

Discussion

Registration of the SN-line

During growth, nasion may be displaced upward or downward due to apposition in the glabella region. Displacement of sella may happen as a consequence of eccentric remodeling of sella turcica. In order to reduce these sources of error, Björk and Skieller¹⁰ recommended a method by which the SN line is transferred from the first radiograph to the subsequent ones after superimposition on stable natural structures in the anterior cranial base and the cranial vault. In the present study, however, this method was found to be somewhat awkward and inaccurate due to increase in the distance between sella and the anterior contours of the middle cranial fossae, especially in the 6- to 12-year period. This made it impossible to superimpose simultaneously on, for instance, sella and the cribriform plate. Adjustment of possible displacement of nasion and sella was therefore not carried out.

Table 6
Correlations between dimensional changes and
mandibular rotation in the 6-12 year period (n=30)

Variables	Total rot.	Matrix rot.	Intramatrix rot.
1. B-pg sag	-0.695***	-0.519**	-0.441*
4. n-gn vert	0.542**	0.389*	0.358
6. sp-gn vert	0.486**	0.429*	0.249
9. pm-go vert	-0.375*	-0.676***	0.118
13. s-cd	-0.407*	-0.303	-0.258
17. B-pg	0.313	0.366*	0.079
18. go-B	-0.482**	-0.467**	-0.209
19. NP-is	0.498**	0.449*	0.245
21. ii-MP	0.521**	0.344	0.370*
23. pm-MP	-0.188	-0.416*	0.128
30. MP-SN	0.790***	0.894***	0.227
31. MP-RL	0.421*	0.612***	-0.001

*P≤0.05, r≥0.361, **P≤0.01, r≥0.463, ***P≤0.001, r≥0.570, n=30, df=28.

Dimensional change and mandibular growth rotation

Tables 4 and 5 suggest that dimensional group differences were dependent upon a different matrix rotation. In the 6- to 12-year period, when the mandibular matrix rotated clearly most forward in the low angle group, dimensional group differences were considerable. Between ages 12 and 15, matrix rotation in the high angle group underwent a remarkable change. From being only slightly marked in the previous period, it turned forward at a rate equal to matrix rotation in the low angle group (Table 5). So, when matrix rotation became similar, the same thing happened with the dimensional changes in the two groups (Table 4).

In the 6- to 12-year period, dimensional changes were far more often significantly correlated with matrix rotation than intramatrix rotation (Table 6). This supports the assumption that dimensional group differences in that period were primarily explained by different mandibular matrix rotation.

In the high angle group, intramatrix rotation developed contrary to matrix rotation and decelerated from 12 to 15 years of age (Table 5). This was to be expected. When the direction of total rotation is more forward than matrix rotation, the difference is due to intramatrix rotation. Consequently, when matrix rotation increased relative to total rotation, intramatrix rotation decreased. The clear group difference

in intramatrix rotation in the 12- to 15-year period (Table 5) did not give rise to dimensional differences between the groups (Table 4). Not unexpected, intramatrix rotation generally had a nonsignificant influence on dimensional changes.

Posterior facial height

According to Björk,¹³ marked development of posterior facial height leads to anterior growth rotation of the mandible, and incomplete development is combined with posterior jaw rotation. Furthermore, mandibular growth rotation has little influence on the upper face, only on the lower face. The present findings resemble Björk's description. Accordingly, a group difference in increase of posterior facial height in the 6- to 12-year period did not include the upper facial height, only the lower, with greater increase in the low angle group (Table 4, vv 9, 23), where mandibular rotation was clearly more forward than in the high angle group (Table 5). It seems likely that the group difference in increase of the posterior lower facial height was closely associated with the difference in matrix rotation of the mandibular corpus. As seen in Table 6 (vv 9, 23), increase in posterior lower facial height and matrix rotation were strongly correlated.

Anterior facial height

Between ages 6 and 12, anterior upper facial height increased equally in the groups. Anterior lower facial height, on the other hand, increased clearly more in the high angle than in the low angle group (Table 4, v 6). Probably this was only partly due to the mandible rotating less forward with the high angle cases than with the low. Most likely the mandibular plane inclination per se also played a causal part. Thus, in both groups gonion was lowered caudally and, on the average, slightly distally, i.e., nearly parallel with the vertical axis of the face. When the mandibular corpus increased in length, the increase was primarily anterocaudally directed, causing the anterior facial height to increase as well. The vertical component of corpus increase must have been greatest where the mandibular plane was steep. Figure 4 illustrates an average case in the high angle group in the 6- to 12-year period. The MP-SN angle decreased due to anterior mandibular rotation. In spite of that, anterior lower facial height increased 5 mm more than posterior lower face height. This was, as shown in Figure 4, a result of the steep mandibular plane giving rise to a large vertical component of corpus increase.

In the 6- to 12-year period, the mandibular plane (MP) was rotated a little more forward than the mandibular matrix (ML_1) relative to SN. This was true in both groups (compare Table 4, v 30 and Table 5, matrix rotation). Probably, the inclination of MP and, consequently, the vertical position of gnathion, were not only influenced by matrix rotation, but also by intramatrix rotation, which tended to be most forward in the low angle group in that period ($P=0.13$, Table 5). Thus, increases in anterior facial heights were positively correlated not only with matrix rotation, but presumably also slightly with intramatrix rotation. This could explain why increases in anterior facial heights were correlated more strongly with total rotation than with matrix rotation alone (Table 6, vv 4, 6), since total rotation is defined by the sum of matrix and intramatrix rotation.

The mandibular corpus

Implant studies¹⁴ have shown that the surface of the symphysis is usually not remodeled. Therefore, the inclination of the symphysis may indicate the direction of mandibular growth rotation: When the mandible rotates anteriorly, the symphysis swings forward in the face and the chin is more prominent; with posterior jaw rotation the symphysis swings backward, with a receding chin. Evaluation of mandibular rotation is complicated by the simultaneous remodeling of the alveolar process in the opposite direction.

Accordingly, in the present study the sagittal distance between B point and pogonion increased in both groups throughout the 6- to 15-year period. In the 6- to 12-year period, however, the increase was greatest in the low angle group, where the anterior mandibular rotation was most notable (Table 4, v 1). The sagittal distance B-pg was almost equally correlated with matrix and intramatrix rotation (Table 6, v 1). This is an indication that changes in inclination of the symphysis reflected the total rotation of the mandible.

Visually, the greater increase in distance B-pg in the low angle group gave the impression of being due to an increase in length of the mental process (distance B-pg'), which, however, was not the case at all. In the 6- to 12-year period, the mental process increased the most in the high angle group (Table 4, v 17). Seemingly, the B-point area was remodelled opposite in the two groups with apposition in the low angle and resorption in the high angle group. The remaining portion of the mandibular corpus (distance go-B) developed,

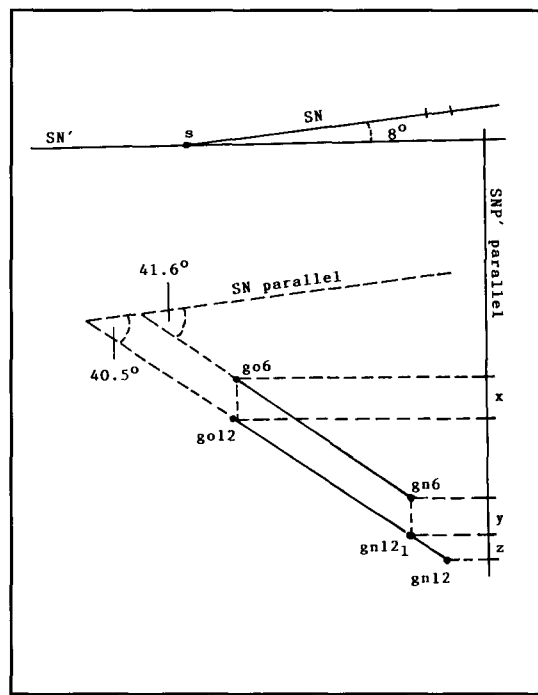

Figure 4

Figure 4

Average increase in anterior ($y+z$) and posterior (x) facial height in the high angle group between ages 6 and 12, superimposed on the anterior cranial base. In this period gonion was lowered nearly vertically ($go6 - go12$), while gnathion's respective lowering ($gn6 - gn12_1$) was a little less when the MP-SN angle decreased 1.1° due to anterior mandibular rotation. In addition, however, gnathion moved anteriorly and caudally ($gn12_1 - gn12$) as the mandibular corpus lengthened. In this way a rather paradoxical situation presented itself: Anterior facial height increased 14.6 mm and posterior facial height only 9.5 mm, while the mandibular plane became slightly less inclined. Due to the steep mandibular plane, distance z was relatively large. At the same time the MP-SN decrease was moderate, so that distance y did not differ much from distance x .

as could be expected, contrary to the mental process and increased most in the low angle group from 6 to 12 years of age (Table 4, v 18).

The jaw angle

When the mandible rotates during growth, remodeling at the lower border of the mandible is less complete than at the posterior border of the ramus. Consequently, when the mandible rotates forward, the jaw angle gets smaller.¹⁵ In the present study, decrease in the jaw angle was very much correlated with matrix rotation and not with the intramatrix rotation of the mandibular corpus (Table 6, v 31). So, the jaw angle decreased steadily in both groups as the matrix rotated forward. In the 6- to 12-year period, however, the decrease was greatest in the group where matrix rotation was most forward. Later on, when a group difference in matrix rotation was no longer present, the decrease was pretty much the same in the two groups (Table 4, v 31).

Clinical considerations

From a clinical point of view the present findings create a rather optimistic picture regarding the craniofacial growth patterns of high MP-SN angle cases. Surprisingly, the high angle group had no cases of posterior total rotation of the mandible. This is an indication that true "posterior rotators" occur more rarely than what has been previously assumed. Further, the findings confirm that dentoalveolar mechanisms have a great potential in compensating vertical skeletal deviations. Thus, vertical overbite developed fairly similarly in the low and high angle groups. Overdevelopment of anterior lower facial height in the latter was compensated by marked growth of the incisal heights of both jaws (Table 4, vv 19, 21).

Conclusions

In the 6- to 12-year period, group differences in dimensional change were numerous; in the following 3-year period they ceased to exist. Obviously, dimensional group differences could be explained by different matrix rota-

tion. This was the case between ages 6 and 12, when matrix rotation was clearly more forward in the low angle than in the high angle group, but not later. Statistically, dimensional variables with significant group difference were correlated strongly with matrix rotation. Furthermore, such variables followed a morphological pattern that could be theoretically related to the group difference in mandibular rotation. This, for instance, involved the anterior lower and posterior lower facial heights, the inclination of the symphysis, and the length of the mental process. Discriminant analysis showed that increments of the four variables, in combination, differentiated nearly 100% correctly between the low and high angle groups in the 6- to 12-year period.

Author Address

Alf Tor Karlsen
Kjøpmannsgt. 34
N-7500 Stjørdal
NORWAY

References

- Schudy FF. The rotation of the mandible resulting from growth: its implications in orthodontic treatment. *Angle Orthod* 1965;35:36-50.
- Isaacson JR, Isaacson RJ, Speidel TM, Worms FW. Extreme variation in vertical face growth and associated variation in the skeletal and dental relations. *Angle Orthod* 1971;41:219-229.
- Björk A. Variations in the growth pattern of the human mandible: longitudinal radiographic study by the implant method. *J Dent Res* 1963;42:400-411.
- Skieller V, Björk A, Linde-Hansen T. Prediction of mandibular growth rotation evaluated from a longitudinal implant sample. *Am J Orthod* 1984;86:359-370.
- Bishara SE, Augspurger EF. The role of mandibular plane inclination in orthodontic diagnosis. *Angle Orthod* 1975;45:273-281.
- Tanner JM. *Growth at adolescence*. Ed. 2, Oxford: Blackwell Scientific Publications Ltd., 1962.
- Broadbent BH, Broadbent BH, Golden WH. *Bolton standards of dentofacial development growth*. St. Louis: Mosby, 1975.
- Karlsen AT. Craniofacial characteristics in children with Angle Class II div. 2 malocclusion combined with extreme deep bite. *Angle Orthod* 1994;64:123-130.
- Craig CE. The skeletal patterns characteristic of Class I and Class II, Division 1 malocclusions in norma lateralis. *Angle Orthod* 1951;21:44-56.
- Björk A, Skieller V. Normal and abnormal growth of the mandible. A synthesis of longitudinal cephalometric implant studies over a period of 25 years. *Eur J Orthod* 1983;5:1-46.
- Slagsvold O. *Variasjoner i kraniets breddedimensjoner*. Universitetet i Oslo, 1966.
- Dixon WJ. *BMDP Statistical Software*. University of California, 1981.
- Björk A. Variationer i kaebernes relation til det øvrige kranium. In Lundström A. (ed.): *Nordisk lärobok i odontologisk ortopedi*. Stockholm: Sveriges Tandläkareförbunds Förlagsförening u.p.a., 1958.
- Björk A. Prediction of mandibular growth rotation. *Am J Orthod* 1969;55:585-599.
- Björk A, Skieller V. Facial development and tooth eruption. An implant study at the age of puberty. *Am J Orthod* 1972;62:339-383.