

Shear and Bending Strength of some End to End Grained Joints Prepared from Scotch Pine

Hanifi TOKGÖZ

Gazi Univ. Faculty of Technical Education, Building Department, Ankara-TURKEY

Ayhan ÖZÇİFÇİ, Musa ATAR

Gazi Univ. Faculty of Technical Education, Furniture Department, Ankara-TURKEY

Burhanettin UYSAL

Zonguldak Karaelmas Üniv. Safranbolu College, Karabuk-TURKEY

Received: 20.03.1998

Abstract: This study was carried out to determine the shear and bending strength of different end-to-end grain joints, which were glued with PVAc (polyvinyl acetate). For this reason, specimens, prepared from scotch pine (*Pinus sylvestris* L.), were made with three types of end to end grain joints namely: half-lap, mortise and tenon and double mortise-and-tenon.

End-to-end grain of half-lap joints gave the highest strength in shear (2.385 N/mm²) and bending (0.540 N/mm²) experiments.

Sarıçam Odunundan Hazırlanan Farklı Boy Birleştirmelerin Kesme ve Eğilme Dirençleri

Özet: Bu çalışma, yapı elamanı olarak kullanılan sarıçam odununun polivinil asetat (PVAc) tutkalı ile yapılan farklı boy birleştirmelerin kesme ve eğilme dirençlerini belirlemek amacıyla yapılmıştır. Bu maksatla, sarıçam (*Pinus sylvestris* L.) odunundan kertme, tam (tek) ve çift zıvanalı olarak hazırlanan ve PVAc tutkalı ile birleştirilen örnekler kesme ve eğilme direnci deneyleri uygulanmıştır.

Sonuç olarak, kertme zıvanalı boy birleştirme; kesme (2.385 N/mm²) ve eğilme deneylerinde (0.540 N/mm²) en yüksek direnci vermiştir.

Introduction

In the past, woods which were used as building and furniture material could be joined by using different joining types according to their function. Except joints which are made using nails and naillike fastening devices, shouldered, mortise, dowel, and blind dovetail joints have also been used in handicrafts, and these joints are used for assembling of pieces of windows, doors, wooden buildings and solid furniture today (1).

If glue is used as the adhesive material, the performance of the wooden pieces joined can be tested after the hardening of glue in the joint section (2).

Differences in the static bending process of wood impregnated with chemical substances including boron were investigated and it were determined that acidic solutions caused a decrease in bending strength (3).

A study was performed for the determination of the gluing strength of klebit 303, kleiberit 305.0 and super lackleim 308 applied on the joint surface of oriental beech, oak and scotch pine wood. Results showed that

klebit 303 glue used on oriental beech gave the highest shear strength (89.80 N/mm²) while klebit 303 glue used on scotch pine gave the lowest shear strength (50.45 N/mm²), super lackleim 308 glue used on oak gave the lowest shear strength (50.18 N/mm²) (4).

Shear strength experiments on joints with different wood species, particle board and fibreboard were performed. This study was performed for the determination of strength of dowel joints glued with polyvinyl acetate (PVAc) and desmodur-VTKA. The highest shear strength values were obtained with oriental beech wood in the direction of its width (4.403 N/mm²) and with solid edged fibreboard (5.818 N/mm²) (5).

In another study, the aim was to determine whether some wood bleaching chemical substances influence bonding strength or not. It was concluded that the decrease in bending strength mostly was caused by hypochlorite and hydrochloride acid solutions (6).

Changes in static bending strength which were seen in scotch pine and oriental beech, treated with some chemi-

cal substances including Boron (PEG-400, ammonium sulphate, diamonium phosphate and vacsol) and a secondary process, water repellent chemicals were examined. Acidic chemicals reduced the bending strength in scotch pine, whereas basic solutions in oriental beech gave the best result (7).

It was explained that of the scotch pine and picea orientalis woods which were impregnated with salts dissolved in water, their bending, shear and shock strengths were decreased, but their pressure strength was increased, in underground mining (8).

It was found that of the scotch pine which was impregnated with sodium fluorosilicate and fluorosil, compression and bending resistance was not changed after 18 years and 3 months (9).

It was determined that chrome and copper salts did not affect the bending strength of scotch pine (10).

Materials and Methods

Scotch pine which is from needle leaf woods, used in building and joinery was chosen randomly in wet condition from a timber warehouse in Ankara. They were stored in an air conditioned room at $20 \pm 2^\circ\text{C}$ and $65 \pm 3\%$ relative humidity until they reached a stable weight.

The samples were cut as $200 \times 50 \times 20 \pm 1$ mm from wooden specimens climatized in an air conditioned room. Ten specimens were prepared according to the procedure of ASTM-D 358 for every joint type (11).

Half-lap, mortise and tenon, double mortise and tenon joints were prepared as shown in Figure 1 (12).

Prepared specimens were left in an air conditioned

room at $20 \pm 2^\circ\text{C}$ and $65 \pm 3\%$ relative humidity, until they reached stable weight. Ten specimens were randomly chosen for humidity verification. It was performed and they were measured to reach about 12 % moisture content.

Glue

In order to join the prepared specimens, PVAc glue was used. PVAc is used as assembly glue in the furniture industry. It has some advantages, namely: it can be applied cold, it spreads easily and hardens quickly, it is not inflammable, the cutting tool does not wear away quickly when it is cut, etc. However, its mechanical resistance is limited and when temperature increases PVAc softens after processing (1).

It is enough to glue joining surfaces with $150\text{-}200 \text{ g/m}^2$ PVAc according to the wood and joint type for a good joining. In the application PVAc glue was chosen according to the procedure of Turkish Standard (TS) 3891. Humidity contents of wood were given as 6-15% in joining of solid wood material. PVAc has 1.1 g/m^3 density, 160-200 cps viscosity, pH 5, 3% ash contents. The pressing time was 20 minutes at 20°C cold gluing. With 2 minutes at 80°C it is advised that the glued parts should be kept in pressing environment until its temperature decreases (13).

Methods

Preparation of Experiments

Shear strength experiments were performed using a 4000 kp capacity universal machine while bending

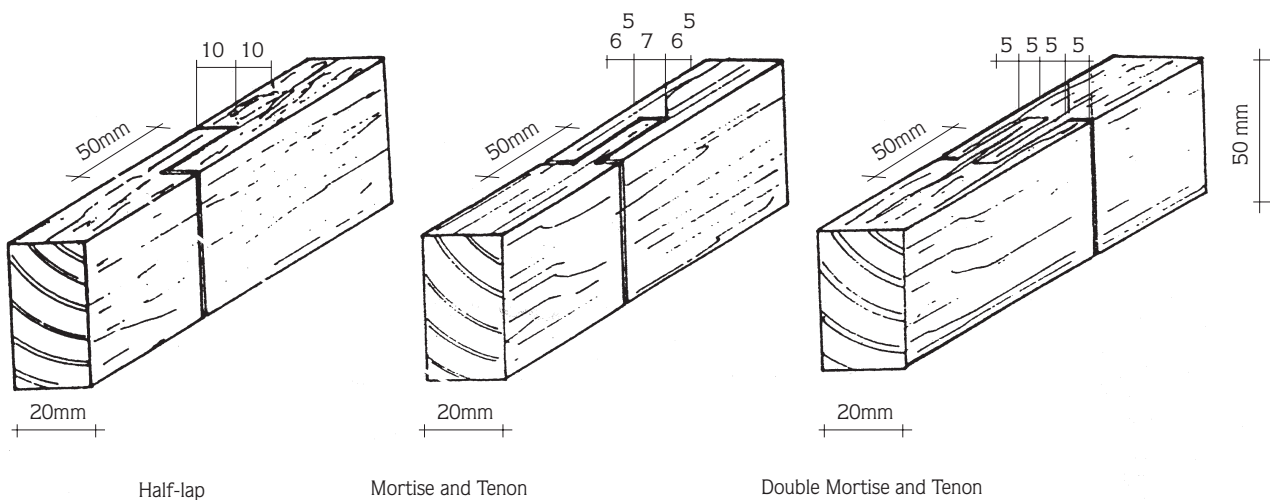

Figure 1. Prepared Specimens

strength experiments were performed using a 3000 kp capacity universal machine, by applying 50 mm/min loading time at shear strength tests, as shown in Figures 2 and 3 (14).

During the shear experiment the specimens' glued faces were loaded until displacement occurred. During this time with the help of measured fracture load (F max) and glued face area (A mm²) shear strength was calculated by following formula:

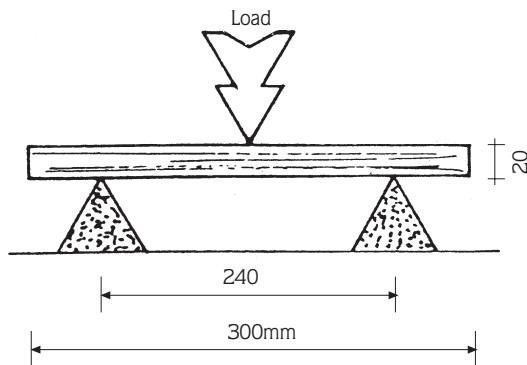

Figure 2. Bending Experiment Apparatus.

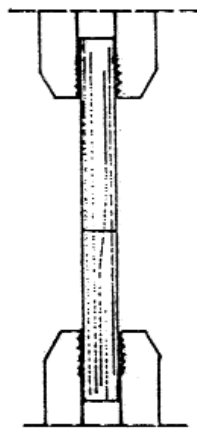

Figure. Shear Experiment Apparatus

$$\sigma_k = \frac{F \max}{A} = \frac{F \max}{a \times b} \text{ N/mm}^2$$

where σ_k = shear strength (N/mm²)

F max = maximum load

a = width of glued face (50 mm)

b = length of glued face (50 mm)

According to the standards of the bending experiment stated in TS 2474, 3000 kP capacity experiment machine was adjusted to apply 6 mm/min loading speed (15).

$$\sigma_e = \frac{3F \max L}{2bh^2} = \text{N/mm}^2$$

σ_e = Bending strength (N/mm²)

F max = Maximum load (N)

L = Distance between two supports (240 mm)

b = Width of face (50 mm)

h = Specimen thickness (20 mm)

Data Analysis

For shear and bending strength experiments a total of 60 specimens were prepared; for every construction type ten specimens were prepared for the determination of difference in prepared specimens shear and bending strengths on joint surfaces; multiple variance analysis was used to determine the differences among the groups. With the Duncan test it was determined whether the differences were significant. Each test group was compared with the others and itself (16).

Results and Discussion

The averages of the results were calculated, and are listed in Table 1 and their variance analysis results are listed in Tables 2 and 3.

According to variance analysis results, differences in groups were statistically significant with a 5% error. The Duncan test was performed to determine in which groups the differences were. It was found that the differences were significant and the results of the Duncan test are listed in Tables 4 and 5.

Half-lap joints gave the highest shear strength (3.8856 N/mm²), double mortise and tenon joints gave the lowest shear strength (2.2014 N/mm²) according to Tables 4 and 5.

In the bending strength tests, the highest value was obtained with half-lap joints (0.5404 N/mm²) and the lowest value was obtained with double mortise and tenon joints (0.4015 N/mm²).

The graphs of bending and shear strength experiments are shown in Figure 4.

Conclusion

In this study, bending and shear strengths of various length joints with PVAc glue and scotch pine were tested.

Average bending strength in half-lap joint was 3.8856

Table 1. Bending and Shear Strengths According to the Joints (Constructions) (N/mm²)

Shear Strengths			Bending Strengths		
Mortise and tenon joints	Double mortise and tenon	Half-lap joints	Mortise and tenon joints	Double mortise and tenon joints	Half-lap Joints and tenon joints
2.640	2.201	3.885	0.435	0.401	0.540

Table 2. Variance Analysis Result of Bending Strengths of Different Construction Types

Sour. of Vari.	Sum of Squa.	D.F.	Mean Squa.	F-ratio	Sig. level
Between groups	0.1047969	2	0.0523984	63.631	0.000
Within groups	0.222233	27	0.00088231		
Total	0.1270202	29			

Table 3. Variance Analysis Result of Shear Strengths of Different Construction Types

Sour. of Vari.	Sum of Squa.	D.F.	Mean Squa.	F-ratio	Sig. level
Between groups	15.265912	2	7.6329561	133.311	0.000
Within groups	1.545929	27	0.572566		
Total	16.811841	29			

Table 4. Results of the Duncan Test Depending on Shear Strength

Types of Construction	Average	Homogeneous
Half-lap Joints	3.8856	A
Mortise-and-Tenon Joints	2.6404	B
Double Mortise-and-Tenon Joints	2.2014	C

Table 5. Results of the Duncan Test Depending on Bending Strength

Types of Construction	Average	Homogeneous
Half-lap Joints	0.5404	A
Mortise-and-Tenon Joints	0.4356	B
Double Mortise-and-Tenon Joints	0.4015	C

N/mm², the highest value, in double mortise and tenon joint is 2.2014 N/mm², the lowest value.

In half-lap joint the average shear strength is was highest (0.5404 N/mm²) and in double mortise and tenon joint the average shear strength is was lowest (0.4015 N/mm²).

According to the experiment, the shear strengths of the end-to-end grain joints types and glue used were consistent with the results in the literature and the values were defined in the standards.

It can be said that the highest value is obtained in bending and shear strength experiments of half-lap joint due to the cut out area being small and the glued surface also being small.

According to these results when scotch pine is used as a large auxiliary material in civil works, the half-lap joint is recommended.

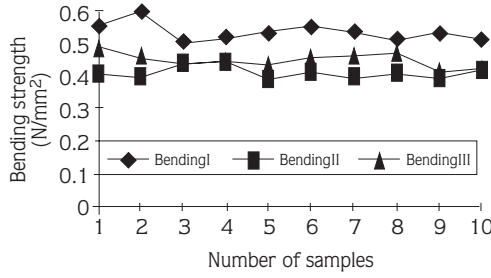

Bending I: Half-lap Joint

Bending II: Double mortise and tenon joint

Bending III: Mortise and tenon joint

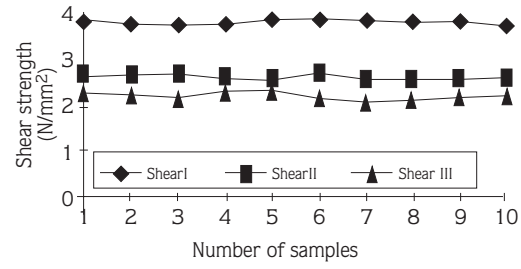

Shear I: Half-lap joint

Shear II: Mortise and tenon joint

Shear III: Double mortise and tenon joint

Figure 4. Bending and Shear Strengths

References

- Örs, Y., Kama Dişli Birleşmeli Masif Ağaç Malzemede Mekanik Özellikler, Yardımcı Ders Kitabı, K.T.Ü. Orman Fakültesi, s 29-34, Trabzon, 1987.
- Rugge, K., Stand der Technologie Beim Keilzinken von Holz, Holz als Roh-und Werkstoff, 403-411, 34, 1976.
- Peker, P., Değişik Ağaç Türlerinde Yangın Geciktirici Kimyasal Maddelerin Eğilme Direnci Üzerine Etkileri, Yüksek Lisans Tezi, KTÜ, Fen Bil. Ensti, Trabzon, 1994.
- Örs, Y., Özçifçi, A., Atar, M., Klebit 303, Kleyberit 305.0 ve Süper-Lackleim 308 Tutkallarının Yapışma Dirençleri, TÜBYTAK Türk Tarım ve Ormancılık Dergisi (Baskıda), Ankara-Türkiye, 1998.
- Örs, Y., Atar, M., Özçifçi, A., Farklı Ağaç Türleri ile Yonga ve Lif Levhalarda PVAc veya Desmodur-VTKA Tutkalı Kullanılarak Uygulanan Kavelalarda Çekme Mukavemeti, TÜBİTAK Türk Tarım ve Ormancılık Dergisi (Baskıda), Ankara-Türkiye, 1998.
- Uysal, B., Atar, M., Özçifçi, A., The Effects of Wood Bleaching Chemicals on the Bending Strength of Wood, Turkish Journal of Agriculture and Forestry (Printed), Ankara-Turkey, 1998.
- Yalınkılıç, M.K., vd., Değişik Ağaç Türlerinde Yangın Geciktirici ve Su Itici Kimyasal Maddelerin Eğilme Direnci Üzerine Etkileri, I. Ulusal Mobilya Kongresi, Bildiri Kitabı, Ankara-Türkiye, 1997.
- Kollman, F., Die Eigenschaftänderung von Grubenholz Nach Schutzsalz Impragnierung, Forschungsber. Des Landes Nordrhein-Westfale, 1959.
- Perkitny, T., Chudzicki, Z., Wplywnasycania Preparatem Flurasil, Przemyslowa Sola Kucahenna i Fluorokrzemianem Sodowym namechaniczne Wlasciwosci Drewna Sosnowege Sylwan; 95,1951.
- Terentjev, W., Wlijanje Ntiseptika Km-5 na Mechanitscheskije Svojtva Drevesny, Derevoobrab. Prom.,21, 1972.
- ASTM-D 358., Wood to be Used as Panels in Weathering Tests of Coatings, 1983.
- TS 4499. Ahşap Birleştirmeler-Terimler Tanymlar. Türk Standartlary Enstitüsü, 1985.
- TS 3891., Yapıştırıcılar - Polivinilasetat Emilsiyon, Türk Stand. Enst.Ankara, 1983
- Eckelman, C.A., Daniel, L., Cassens Withdrawal Strength of Dowels from Wood Composites, Forest Product Journal, Madison-USA, vol. 35, no 11, p 55, 1985.
- TS 2474. Odunun Statik Eğilme Dayanımının Tayini, Türk Stand. Enst.Ankara, 1976.
- Ünver, Ö., Gamgam, H., Uygulamalı İstatistik Yöntemler, Ders Kitabı, s 208 - 219, Ankara, 1986.