

Integral Constraints on Bottom and Surface Isolated Eddies

MATHIEU MORY

Institut de Mécanique de Grenoble, Domaine Universitaire, 38402 St Martin d'Hères cédex/France

(Manuscript received 15 February 1985, in final form 30 April 1985)

ABSTRACT

General integral relationships are derived for joint eddies in a three-layer ocean model as considered by Nof. The model is composed of two eddies in two superposed layers, the third layer being motionless. Two cases are examined, first when the two active layers are near the bottom (bottom eddies) and, second, when they are located near the surface of the ocean (surface eddies). For bottom eddies the β effect is due to the presence of a slope as a bottom topography. For surface eddies the β effect comes in through the variation with latitude of the Coriolis frequency.

The novelty of the present work consists in the derivation of mathematically exact integral properties, from which the translation speed of the system is deduced. Contrary to Nof no scaling assumptions are made and therefore the result applies to a wide range of physical situations. In particular, barotropic isolated vortices and bottom eddies in a two layer ocean are within the range of application of the present results since the Boussinesq approximation has not been used in the study. Consequently, the integral theorems given in this paper extend previous theorems by Flierl and Stern. The paper's emphasis is on the mathematical aspects but important physical implications are readily deduced from the general result. In particular, as was first pointed by Nof, it is shown that isolated eddies propagate eastward under certain conditions.

1. Introduction

In recent years, much attention has been paid to the dynamics of so called isolated eddies. Such eddies are observed in the ocean (Ring-Group, 1981) and it is now recognized that they play a key role. The displacement of isolated eddies is constrained by the presence of the β effect which tends to impose an east-west propagation of the system.

Those isolated systems usually show very coherent features. Thus, the various analytical models which have been proposed have been kept simple. Among them are the modons (Stern, 1975), the warm and cold rings (Flierl, 1979) and the cold eddies on a sloping bottom (Nof, 1983; Killworth, 1983; Mory, 1983). The isolation property gives rise to simple analytical constraints on the eddy which are derived by integrating the momentum equation over the whole space. Integral constraint properties were demonstrated for a barotropic flow (Flierl *et al.*, 1983) and for core cold eddies on a sloping bottom by Stern (see Mory, 1983).

The present paper was motivated by the recent work of Nof (1985) which considers joint eddies. It extends the integral theorems of Flierl *et al.* (1983) and Stern (Mory, 1983) to a more general case for a three-layer ocean. The system consists in an isolated pair of vortices located on top of each other. One of the active layers is finite so that it may be looked at as a lens. The third layer is motionless and of infinite depth. Depending on whether the active layers are above or below

the infinitely deep layer, we call the system surface joint vortices or bottom joint vortices. Both systems were studied by Nof who determined the translation speed for a particular case of large amplitude mesoscale eddies.

The present work shows that translation speeds can be obtained from exact integral relationships without making any scale assumption. Furthermore, it will be shown that the cold eddies on a sloping bottom studied by Nof (1983) and Mory (1983) are limiting cases of the theorem derived here. Contrarily to previous studies, we do not use the Boussinesq approximation, and the consequences will become apparent through the analysis.

The present paper emphasizes the mathematical model of isolated joint vortices, pointing out however some physical consequences of the theory. In particular, it substantiates the conjecture that joint eddies may translate eastward under certain circumstances as has been pointed out by Nof (1985). The reader is referred to the latter paper where the properties of various kinds of eddies are summarized.

The model is rather simple since it is restricted to joint eddies translating at constant speed C along the east-west axis. This is a usual simplification but it should be kept in mind that some more complicated displacements are possible, as inertial oscillations (see Nof, 1984).

The paper has two main sections. Bottom joint eddies are considered in Section 2, and Section 3 deals

with surface joint eddies. Due to the close relation with Nof's paper we use the same conventions as he did (see Figs. 1, 2, 3).

2. Integral constraint on bottom ocean eddies

A schematic diagram of a bottom eddy in a three layer ocean model is shown in Fig. 1. The ocean is supposed to be deep, i.e. the upper layer is motionless and of infinite depth. The motions in the two lower layers are taken as two-dimensional. The lower layer (reference subscript 1) consists in a finite volume lens on a sloping bottom.

The momentum and continuity equations are written for the lens in the form

$$(\rho + \Delta\rho_2)\left(\frac{\partial}{\partial t} \mathbf{v}_1 + (\mathbf{v}_1 \cdot \nabla)\mathbf{v}_1\right) + f(\rho + \Delta\rho_2)\mathbf{k} \times \mathbf{v}_1 = -\nabla p_1 \quad (2.1)$$

$$\frac{\partial}{\partial t} h_1 + \nabla \cdot (\mathbf{v}_1 h_1) = 0. \quad (2.2)$$

For the intermediate layer (subscript 2) the equations are

$$\rho\left(\frac{\partial}{\partial t} \mathbf{v}_2 + (\mathbf{v}_2 \cdot \nabla)\mathbf{v}_2\right) + f\rho\mathbf{k} \times \mathbf{v}_2 = -\nabla p_2 \quad (2.3)$$

$$\frac{\partial}{\partial t} h_2 + \nabla \cdot (\mathbf{v}_2 h_2) = 0. \quad (2.4)$$

The pressure is hydrostatic. The gravity terms are therefore incorporated in the pressures p_1 and p_2 , which are expressed as follows:

$$p_2 = p_0 + \rho g(H - z) + \Delta\rho_1 g \xi_2 \quad (2.5)$$

$$p_1 = p_0 + \rho g(H - z) + \Delta\rho_1 g \xi_2 + \Delta\rho_2 g(h_1 - z + sy). \quad (2.6)$$

The presence of the sloping bottom tends to restrict the motion of the system (lens + vortex in layer 2) to east-west motions. In addition, we assume that the

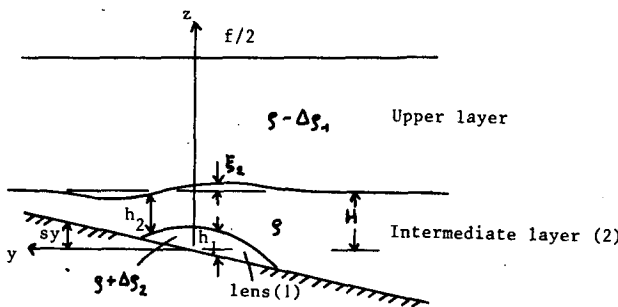

FIG. 1. A sketch of bottom joint eddies on a sloping bottom. The upper layer is motionless and of infinite depth. The lower layer (subscript 1) consists in a lens on the bottom. The depths of the lens and of the intermediate layer (subscript 2) are designated respectively by h_1 and h_2 . ξ_2 is the displacement of the interface between the upper and the intermediate layers.

system propagates steadily at speed C along the x axis. The time derivative $\partial/\partial t$ is then replaced by $-C(\partial/\partial x)$ and the continuity equations (2.2) and (2.4) reduce to

$$\nabla \cdot \{(\mathbf{v}_1 - C\mathbf{i})h_1\} = 0 \quad (2.7)$$

$$\nabla \cdot \{(\mathbf{v}_2 - C\mathbf{i})h_2\} = 0. \quad (2.8)$$

Equations (2.7) and (2.8) lead to the existence of a streamfunction ψ in term of which the momentum (integrated over the depths of the two layers) is expressed

$$(\rho + \Delta\rho_2)\mathbf{v}_1 h_1 + \rho\mathbf{v}_2 h_2 = \rho C\mathbf{i}(h_1 + h_2) + \Delta\rho_2 C h_1 \mathbf{i} + \rho\mathbf{k} \times \nabla\psi. \quad (2.9)$$

The Boussinesq approximation is not used in (2.9) for reasons which will become apparent later.

With the conventions given in Fig. 1 we introduce the streamfunction φ , related to ψ by

$$\psi = \varphi + CHy - Csy^2/2. \quad (2.10)$$

The momentum is then written

$$(\rho + \Delta\rho_2)\mathbf{v}_1 h_1 + \rho\mathbf{v}_2 h_2 = \rho\mathbf{k} \times \nabla\varphi + \Delta\rho_2 C\mathbf{i}h_1 + \rho C\mathbf{i}\xi_2. \quad (2.11)$$

As was previously done for other cases by Flierl *et al.* (1983) and Stern (see Mory, 1983), the derivation of integral constraints relationships is performed by integrating the momentum equation over the whole domain (including layers 1 and 2). This supposes some convergence properties of the integrals. In practice we admit that integrals involving ξ_2 , h_1 and $\nabla\varphi$ are definite. This in general requires that $h_1 \equiv 0$, $\xi_2 = o(1/r^2)$ and $\varphi = o(1/r)$ far away from the eddy (r being the distance from the center of the eddy). Such conditions are quite restrictive but we voluntarily limit the analysis to isolated systems. Under certain circumstances systems which are considered here may however not be isolated and Rossby wavelike wakes may occur.

After multiplying equations (2.1) and (2.3) by h_1 and h_2 respectively and integrating over the plane (x, y) the total momentum equation is obtained. For an isolated vortex the time derivative and the nonlinear terms vanish on integration (the demonstration is given in the Appendix). The two remaining terms are then the Coriolis force in equilibrium with the pressure force. The Coriolis force is expressed by (see Fig. 1 for the notations)

$$f\mathbf{k} \times \int_{-\infty}^{+\infty} \int_{-\infty}^{+\infty} \{(\rho + \Delta\rho_2)\mathbf{v}_1 h_1 + \rho\mathbf{v}_2 h_2\} dx dy = fC\mathbf{j} \int_{-\infty}^{+\infty} \int_{-\infty}^{+\infty} (\xi_2 + \Delta\rho_2 h_1/\rho) dx dy + f\mathbf{k} \times \int_{-\infty}^{+\infty} \int_{-\infty}^{+\infty} \nabla\varphi dx dy. \quad (2.12)$$

Because of the rapid decay of φ far away from the eddy [$\varphi = o(1/r)$], the integral involving the gradient of φ simply disappears in Eq. (2.12), and therefore the total Coriolis force reduces to

$$fC\rho j \int_{-\infty}^{+\infty} (\xi_2 + \Delta\rho_2 h_1/\rho) dx dy. \quad (2.13)$$

The integrated pressure force is derived by using the hydrostatic forms (2.5) and (2.6)

$$-\int_{-\infty}^{+\infty} (\nabla p_1 h_1 + \nabla p_2 h_2) dx dy = -\int_{-\infty}^{+\infty} \{ \Delta\rho_1 g \nabla \xi_2 \times (h_1 + h_2) + \Delta\rho_2 g h_1 \nabla h_1 + \Delta\rho_2 g s h_{1,j} \} dx dy. \quad (2.14)$$

For an isolated system ξ_2 and h_1 vanish far away from the eddy. With the aid of $h_1 + h_2 = H - sy + \xi_2$, all terms on the right hand side of (2.14) involving either $\nabla(\xi_2^2)$, $\nabla \xi_2$ or $\nabla(h_1^2)$ vanish on integration. Equation (2.14) then takes the simple form

$$-\int_{-\infty}^{+\infty} (-\Delta\rho_1 g s y \nabla \xi_2 + \Delta\rho_2 g s h_{1,j}) dx dy \quad (2.15)$$

or, after integration by part of the first term

$$-g s j \int_{-\infty}^{+\infty} (\Delta\rho_1 \xi_2 + \Delta\rho_2 h_1) dx dy. \quad (2.16)$$

By equating the total Coriolis force (2.13) to the total pressure force (2.16) the translation speed C of the system is deduced from

$$Cf \int_{-\infty}^{+\infty} (\xi_2 + \Delta\rho_2 h_1/\rho) dx dy = -gs \int_{-\infty}^{+\infty} (\Delta\rho_1 \xi_2/\rho + \Delta\rho_2 h_1/\rho) dx dy. \quad (2.17)$$

Several consequences emerge from (2.17):

(i) The expression is close to the estimate of the translation speed for a high-amplitude eddy ($\xi_2, h_1 \sim H$) in a deep three-layer ocean ($\Delta\rho_1/\rho, \Delta\rho_2/\rho \ll 1$), obtained by Nof (1985), except that integration was restricted in Nof's calculations to the core of the eddy. The possible existence of eastward translating eddies, first pointed out by Nof, is recovered: C is found to be positive when ξ_2 is itself negative (but still small).

(ii) Equation (2.17), when applied to a two-layer model with a free surface ($\Delta\rho_1 = \rho$) as in Mory's ex-

periment (1983) permits us to recover Stern's integral theorem (see Mory, 1983) which is written

$$\int_{-\infty}^{+\infty} (\xi_2 + \Delta\rho_2 h_1/\rho) dx dy = 0. \quad (2.18)$$

The translation speed C is not deduced from (2.17). Integrals in the left- and right-hand sides of Eq. (2.17) are identical and they have to be equated to zero. Otherwise, the solution of (2.17) would be

$$C = \frac{-gs}{f}, \quad (2.19)$$

which is a nonphysical translation speed. In particular this translation speed is not vanishing in the limit of (2.19) as $\Delta\rho_2/\rho \rightarrow 0$.

The non-Boussinesq theory presented in this paper permits straightforward extensions to cases where the upper layer is the atmosphere ($\Delta\rho_1 = \rho$) and ξ_2 the displacement of the free surface. The Boussinesq approximation is however not critical for the theory. When using the Boussinesq approximation for the two layer model with a free surface, the momentum (left-hand side of Eq. 2.17) is of order $\Delta\rho_2/\rho$. Thus (2.17) still reduces to (2.18) at first order of $\Delta\rho_2/\rho$.

(iii) The translation speed of deep ocean blobs also is given by (2.17). In this case the intermediate layer is removed¹ ($H \rightarrow 0, \xi_2 \rightarrow h_1 + sy$) and the density difference between the lens and the outer ocean is $\Delta\rho = \Delta\rho_1 + \Delta\rho_2$. Equation (2.17) gives the translation speed previously found by Nof (1983)

$$C = \frac{-gs}{f} \frac{(\Delta\rho_1 + \Delta\rho_2)}{(\rho + \Delta\rho_2)} \simeq \frac{-gs}{f} \frac{\Delta\rho}{\rho}. \quad (2.20)$$

3. Integral constraint on surface joint eddies

For bottom eddies, differential Coriolis effects were introduced by the presence of a linear slope at the bottom of the ocean. For surface eddies, this effect is taken into account through the spatial variation of the Coriolis frequency ($f = f_0 + \beta y$). In this section we consider the case of surface joint eddies consisting either in a lens on top of a vortex (see Fig. 2) or in a lens underneath a vortex (see Fig. 3). The two cases were considered by Nof (1985) and we therefore use the same conventions as he did. The derivation of integral constraint relationships is identical for the two cases. The demonstration is given here for a lens on top of an eddy (referred to in Nof's paper as system II; see Fig. 2).

¹ The limiting case ($H \rightarrow 0, \xi_2 \rightarrow h_1 + sy$), although contradicting the hypothesis $\xi_2 \rightarrow 0$ far away from the eddy, leads to a correct estimate of the momentum [which can be directly computed from equation (2.9)]. On the other hand (2.20) is not recovered from (2.17) by considering the intermediate layer to be of infinite depth because Eq. (2.10) no longer holds.

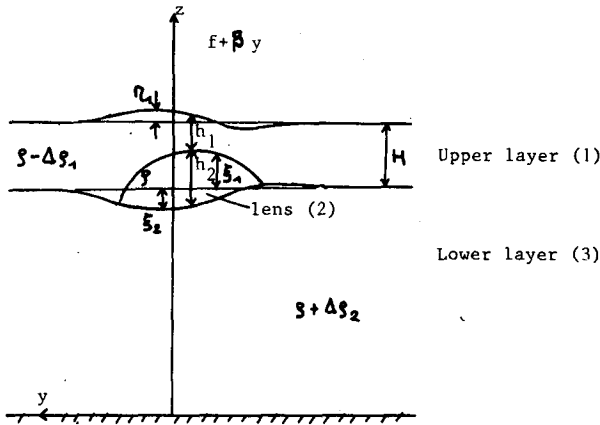

FIG. 2. A sketch of surface joint eddies cited as system II by Nof (1985). The lower layer is motionless and of infinite depth. The intermediate layer (subscript 2) is a lens underneath a vortex in the upper layer (subscript 1). The depths of layers 1 and 2 are respectively designated by h_1 and h_2 . η_1 , ξ_1 and ξ_2 are the displacements of the interfaces from their undisturbed positions.

The momentum and continuity equations are written for the lens (subscript 1) and the intermediate layer (subscript 2):

$$(\rho - \Delta\rho_1)\left(\frac{\partial}{\partial t} \mathbf{v}_1 + (\mathbf{v}_1 \cdot \nabla)\mathbf{v}_1\right) + (f + \beta y)(\rho - \Delta\rho_1)\mathbf{k} \times \mathbf{v}_1 = -\nabla p_1 \quad (3.1)$$

$$\frac{\partial}{\partial t} h_1 + \nabla \cdot (\mathbf{v}_1 h_1) = 0 \quad (3.2)$$

$$\rho \left(\frac{\partial}{\partial t} \mathbf{v}_2 + (\mathbf{v}_2 \cdot \nabla)\mathbf{v}_2 \right) + (f + \beta y)\rho \mathbf{k} \times \mathbf{v}_2 = -\nabla p_2 \quad (3.3)$$

$$\frac{\partial}{\partial t} h_2 + \nabla \cdot (\mathbf{v}_2 h_2) = 0. \quad (3.4)$$

For convenience we use the depths h_1 and h_2 defined by (see Fig. 2)

$$h_1 = \eta_1 - \xi_1 \quad (3.5)$$

$$h_2 = H + \xi_1 - \xi_2. \quad (3.6)$$

The pressure is taken hydrostatic for the upper (p_1), intermediate (p_2) and lower layer (p_3):

$$p_1 = p_0 + (\rho - \Delta\rho_1)g(\eta_1 - z) \quad (3.7)$$

$$p_2 = p_0 + (\rho - \Delta\rho_1)g(\eta_1 - \xi_1) + \rho g(\xi_1 - z) \quad (3.8)$$

$$p_3 = p_0 + (\rho - \Delta\rho_1)g\eta_1 + \Delta\rho_1 g\xi_1 - \rho g z + \Delta\rho_2 g\xi_2. \quad (3.9)$$

The lower layer is supposed to be motionless and of infinite depth. The condition of zero horizontal pressure gradient in that layer leads to the following relationship between η_1 , ξ_1 and ξ_2 :

$$(\rho - \Delta\rho_1)\eta_1 = -\Delta\rho_1\xi_1 - \Delta\rho_2\xi_2. \quad (3.10)$$

The technique and the basic assumptions are similar to the development in section 2:

(i) Translation of the system is at constant speed C in the east-west direction.

(ii) Equations (2.7) and (2.8) still remain valid. The momentum (integrated over layers 1 and 2) is expressed as a function of a stream function ψ :

$$(\rho - \Delta\rho_1)v_1 h_1 + \rho v_2 h_2 = (\rho - \Delta\rho_1)Ch_1 \mathbf{i} + \rho Ch_2 \mathbf{j} + \rho \mathbf{k} \times \nabla \psi. \quad (3.11)$$

(iii) A more significant stream function, related to the motion in the reference frame, is φ which is defined by:

$$\psi = \varphi + CHy. \quad (3.12)$$

(iv) The system is taken to be isolated. Thus, $\eta_1 = \xi_1 \rightarrow 0$ and $\xi_2 \rightarrow 0$ far away from the eddy, in addition to conditions on the decay of φ which will be defined later.

(v) Integration of the momentum equations over the two layers is performed by multiplying Eq. (3.1) and (3.3) by h_1 and h_2 respectively and integrating over the plane (x, y) . The time derivative and the nonlinear terms vanish on integration because the system is isolated. We only have to consider the total pressure force and the total Coriolis force.

(vi) Contrary to the analysis of the previous section, the total pressure force is found to be zero. Applying Eq. (3.5)–(3.8), one gets:

$$-\int_{-\infty}^{+\infty} \int (\nabla p_1 h_1 + \nabla p_2 h_2) dx dy = \int_{-\infty}^{+\infty} \int \{(\rho - \Delta\rho_1)g\nabla\eta_1\xi_2 + \Delta\rho_1 g\xi_2\nabla\xi_1\} dx dy. \quad (3.13)$$

In the latter expression, terms involving $\nabla\eta_1^2$, $\nabla\eta_1$, $\nabla\xi_1$ or $\nabla\xi_1^2$ have been omitted since these vanish on inte-

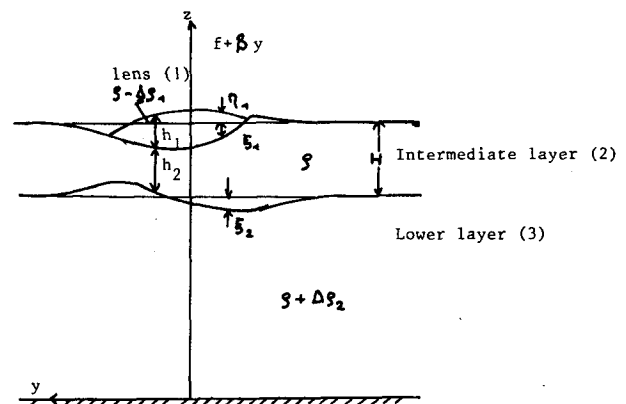

FIG. 3. A sketch of surface joint eddies cited as system III by Nof (1985). The lower layer is motionless and of infinite depth. The upper layer is a lens (subscript 1) above a vortex in the intermediate layer (subscript 2). The depths of layers 1 and 2 are respectively h_1 and h_2 . η_1 , ξ_1 and ξ_2 are the displacements of the interfaces from their undisturbed positions.

gration. By using equation (3.10) it is easily shown that the right hand side integral in equation (3.13) is zero. This is not a surprising result. For bottom eddies (Section 2) the total pressure force was nonzero, due to the presence of the slope (see Eq. 2.16). For the surface eddies considered in the present section the β effect enters in the total Coriolis force.

(vii) The remaining term in the integrated momentum equation, namely the total Coriolis term, is then necessarily zero. This term is simply written with the aid of (3.11)–(3.12) and (3.5)–(3.6) in the form

$$\begin{aligned} \mathbf{k} \times \int_{-\infty}^{+\infty} \int_{-\infty}^{+\infty} \{(\rho - \Delta\rho_1)\mathbf{v}_1 h_1 + \rho\mathbf{v}_2 h_2\} \{f + \beta y\} dx dy \\ = -(\rho + \Delta\rho_2)C\mathbf{j} \int_{-\infty}^{+\infty} \int_{-\infty}^{+\infty} (f + \beta y)\xi_2 dx dy \\ + \rho \int_{-\infty}^{+\infty} \int_{-\infty}^{+\infty} (f + \beta y)\mathbf{k} \times \nabla\varphi dx dy. \end{aligned} \quad (3.14)$$

The second integral on the right-hand side of Eq. (3.14) is modified by an integration by part. Its convergence is obtained under the condition that φ is $o(1/r^2)$ for large distance r from the center of the eddy. The total Coriolis force is then written

$$\begin{aligned} -C(\rho + \Delta\rho_2) \int_{-\infty}^{+\infty} \int_{-\infty}^{+\infty} (f + \beta y)\xi_2 dx dy \\ + \rho \int_{-\infty}^{+\infty} \int_{-\infty}^{+\infty} \beta\varphi dx dy = 0. \end{aligned} \quad (3.15)$$

The translation speed of the system is finally deduced from (3.15):

$$C = \frac{\beta \int_{-\infty}^{+\infty} \int_{-\infty}^{+\infty} \varphi dx dy}{(1 + \Delta\rho_2/\rho) \int_{-\infty}^{+\infty} \int_{-\infty}^{+\infty} (f + \beta y)\xi_2 dx dy}. \quad (3.16)$$

The expression for the translation speed (3.16) is valid for a wide range of physical systems among which are the joint eddies (system II and III) studied by Nof (1985). In this case $\Delta\rho_2 \ll \rho$ and $\beta y \ll f$, so that C is simply

$$C \approx \frac{\beta \int_{-\infty}^{+\infty} \int_{-\infty}^{+\infty} \varphi dx dy}{f \int_{-\infty}^{+\infty} \int_{-\infty}^{+\infty} \xi_2 dx dy}. \quad (3.17)$$

It must be stressed that Eq. (3.15) is an extension of the integral theorem found by Flierl *et al.* (1983) for a one layer model. This theorem states that the integral momentum is zero for an isolated vortex. The integral relationship given by (3.15) comes to the same conclusion and, in particular, one recovers Flierl's result when assuming that $\xi_2 = 0$ so that

$$\beta \int_{-\infty}^{+\infty} \int_{-\infty}^{+\infty} \varphi dx dy = 0. \quad (3.18)$$

4. Conclusion

The main results of the mathematical models are the analytical expressions for the translation speed C for the bottom and surface joint eddies given respectively by Eqs. (2.17) and (3.16). These generalize the approximate solutions obtained by Nof for high amplitude mesoscale eddies. Although the analytical expressions for the translation speed depend on the structure of the eddy which is not known, we call them exact relationships since they were derived without recourse to any scaling assumption. Hence, the results are valid for a wide range of physical systems. As the Boussinesq approximation was not used, the density variations $\Delta\rho_1/\rho$ and $\Delta\rho_2/\rho$ may be of order $O(1)$. Thus, the result for bottom joint eddies (Eq. 2.17) applies to bottom eddies in a two layer ocean model as studied by Nof (1983), assuming an infinite depth of the upper layer, and by Mory (1983), who included free surface effects.

For both cases of joint eddies which were considered, the integrated Coriolis force was found to be nonzero. This explains why the translation speed C is deduced from the integral relationships. Those integral relationships are extensions of the integral theorems of Flierl *et al.* (1983) and Stern (Mory, 1983). Flierl's theorem is a special case of Eq. (3.17) and Stern's integral theorem on the other hand is recovered from Eq. (2.17).

Limitations of integral relationships follow from the requirement of sufficiently fast decay of the perturbation far away from the eddy. It is not obvious whether this really happens in physical situations. However, Nof's results are particular cases of the present solutions, except that integrals were computed by Nof over the finite area of the vortex core. It is likely, although not proved, that the potential vorticity and Bernoulli integrals, deduced by Nof for the domain outside the eddy, do not implicitly contain similar assumptions on the decay of the perturbation.

The present article focuses on the mathematical derivations of integral relationships. A detailed physical description of the applicability of these integral relationships is available in Nof's work (1985). The most striking result is the demonstration that joint eddies may propagate eastward.

Acknowledgments. This work was undertaken while M.M. was a fellow at the Geophysical Fluid Dynamics Summer Study in Woods Hole and the program is acknowledged for the stimulating conditions that were provided. M. E. Stern originally pointed out the importance of integral relationships. Discussions with him and G. R. Flierl were of crucial importance. Further developments gained much benefit from the published work of D. Nof. The study was recently supported by the CNEXO under Contract 84/3276.

APPENDIX

Integral Forms of the Time Derivative and Nonlinear Terms in the Momentum Equation

One demonstrates in this Appendix that the time-derivative and the nonlinear terms in the momentum equation are zero on integration over the whole space for isolated eddies. Demonstration is similar for any case considered in the paper. Thus, we omit the subscripts in the equations. Integrals are computed over each layer contained in the system. For simplicity, the momentum equation is written for each component (u, v) of the velocity:

$$\frac{\partial u}{\partial t} + \frac{\partial u^2}{\partial x} + \frac{\partial uv}{\partial y} = L(u, v) \quad (\text{A1})$$

$$\frac{\partial v}{\partial t} + \frac{\partial uv}{\partial x} + \frac{\partial v^2}{\partial y} = M(u, v) \quad (\text{A2})$$

as well as for the continuity equation:

$$\frac{\partial h}{\partial t} + u \frac{\partial h}{\partial x} + v \frac{\partial h}{\partial y} = 0. \quad (\text{A3})$$

In Eqs. (A1) and (A2), L and M designate the remaining terms in the momentum equation i.e., the Coriolis and the pressure terms. By multiplying (A1) and (5.3) by h and u respectively, and by adding the two resulting equations, one gets

$$\frac{\partial(uh)}{\partial t} + \frac{\partial(hu^2)}{\partial x} + \frac{\partial(huv)}{\partial y} = hL(u, v) \quad (\text{A4})$$

and, in a similar way for (6.2):

$$\frac{\partial(vh)}{\partial t} + \frac{\partial(huv)}{\partial x} + \frac{\partial(hv^2)}{\partial y} = hM(u, v) \quad (\text{A5})$$

Integrated forms of the momentum equation are deduced by integrating (A4) and (A5) over the plane ($x,$

y). Since the motion of the system is restricted to east-west translation at constant speed $C\mathbf{i}$, the time-derivative $\partial/\partial t$ is simply replaced by $-C(\partial/\partial x)$. Thus, the integration of the momentum equation leads to

$$\begin{aligned} -C \iint_{-\infty}^{+\infty} \frac{\partial(uh)}{\partial x} dx dy + \iint_{-\infty}^{+\infty} \left(\frac{\partial(hu^2)}{\partial x} + \frac{\partial(huv)}{\partial y} \right) dx dy \\ = \iint_{-\infty}^{+\infty} hL(u, v) dx dy \quad (\text{A6}) \end{aligned}$$

$$\begin{aligned} -C \iint_{-\infty}^{+\infty} \frac{\partial(vh)}{\partial x} dx dy + \iint_{-\infty}^{+\infty} \left(\frac{\partial(huv)}{\partial x} + \frac{\partial(hv^2)}{\partial y} \right) dx dy \\ = \iint_{-\infty}^{+\infty} hM(u, v) dx dy. \quad (\text{A7}) \end{aligned}$$

Integral forms of the time derivative and the nonlinear terms in the momentum (left hand side terms in A6 and A7) vanish on integration, due to the boundary conditions far away from the eddy which are recalled as follows:

- (i) for a lens, $h = 0$ outside the lens.
- (ii) for a layer of infinite extent in the plane (x, y), u^2 , v^2 and uv can be supposed to decay sufficiently rapidly far away from the eddy. This corresponds to an assumption of finite energy input into the system.

REFERENCES

- Flierl, G. R., 1979: A simple model of the structure of warm and cold-core rings. *J. Geophys. Res.*, **84**, 781-785.
- , M. E. Stern and J. A. Whitehead, Jr., 1983: The physical significance of modons. *Dyn. Atmos. Oceans*, **5**, 1-41.
- Killworth, P. D., 1983: On the motion of isolated lenses on a beta-plane. *J. Phys. Oceanogr.*, **13**, 368-376.
- Mory, M., 1983: Theory and experiment of isolated baroclinic vortices. Tech. Rep., Woods Hole Oceanographic Institute, WHOI-83-41, 114-132.
- Nof, D., 1983: The translation of isolated cold eddies on a sloping bottom. *Deep-Sea Res.*, **39**, 171-182.
- , 1984: Oscillatory drift of deep cold eddies. *Deep-Sea Res.*, in press.
- , 1985: Joint vortices, eastward propagating eddies and migratory Taylor columns. *J. Phys. Oceanogr.*, **15**, 1114-1137.
- Ring-Group, 1981: Gulf Stream cold-core rings: Their physics, chemistry, and biology. *Science*, **212**, 1091-1100.
- Stern, M. E., 1975: Minimal properties of planetary eddies. *J. Mar. Res.*, **33**, 239-267.