



Manufacturing of polymer matrix composites using vacuum assisted resin infusion molding

A. Goren*, C. Atas

Department of Mechanical Engineering, Dokuz Eylül University, 35100, Bornova, Izmir, Turkey

* Corresponding author: E-mail address: aytac.goren@deu.edu.tr

Received 14.08.2008; published in revised form 01.12.2008

ABSTRACT

Purpose: The purpose of the paper is to manufacture the polymer matrix composites using vacuum assisted resin infusion molding.

Design/methodology/approach: Electrical heating resistances are used for heating of table. The temperature control is achieved by means of acquiring temperatures using thermocouples located beneath the table surface. VARIM table is divided into eight regions. Each region has an independent closed loop temperature control system.

Findings: By using a PLC and a touch screen, the system is capable of adjusting the desired temperatures, up to 200°C, and corresponding time intervals for curing cycles. The main advantage of using a PLC as a control unit for this system is to have a flexible control for changing the cure conditions.

Research limitations/implications: The setup is capable of controlling the level of vacuum and the temperature of the heating table, single sided tool. By using the VARIM system, high quality and void-free composite plates are fabricated.

Originality/value: The paper is supposed to give significant tips to researchers who intend to setup and utilize VARIM technology in their works.

Keywords: Polymer; Composite; VARIM technique

MATERIALS MANUFACTURING AND PROCESSING

1. Introduction

There has been a growing interest to use composite materials in structural applications ranging from aircraft and space structures to automotive and marine applications instead of conventional materials. This is because advanced composites exhibit desirable physical and chemical properties that include high specific stiffness and strength, dimensional stability, temperature and chemical resistance, and relatively easy processing. A variety of manufacturing methods can be used according to the end-item design requirements. Most commercially produced composites use a polymer matrix with textile reinforcements such as glass, aramid and carbon.

Vacuum assisted resin infusion techniques have become popular in manufacturing of these composites. In the literature, vacuum infusion is known under different acronyms [6]. The most popular terms to describe vacuum infusion processes are:

VARTM-Vacuum Assisted Resin Transfer Moulding [5, 2], VARIM-Vacuum Assisted Resin Infusion Moulding [4], SCRIMP™-Seemann Composites Resin Infusion Moulding Process [1], VBRM-Vacuum Bag Resin Transfer Moulding [3], VARI-Vacuum Assisted Resin Infusion process [7] and so on. All involve basically the same technology, and describe methods based on the impregnation of a dry reinforcement by liquid thermoset resin driven under vacuum.

In this paper, a step by step procedure regarding manufacturing of composites by an in-house vacuum infusion process, called VARIM, is given. In this process, resin is drawn into a preform through use of a vacuum, rather than pumped in under pressure. It has become a very attractive fabrication technology in recent years because of its low cost tooling and scalability to very large structures. It also minimizes the void contents inside the moulded composites, reduces VOC emissions, and results in less scrap than other moulding techniques [4].

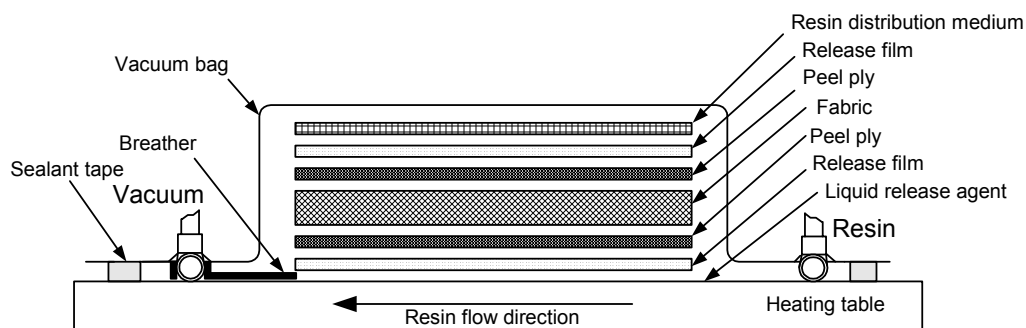

Fig. 1. Schematic illustration of the vacuum assisted resin infusion molding (VARIM) process

2. Description of the (VARIM) process

As indicated earlier, VARIM (Vacuum Assisted Resin Infusion Moulding) is a composite manufacturing process to produce high-quality large-scale components. In this process, dry preform fabrics are placed in an open mould and a plastic vacuum bag is placed on the top of the mould. The one-sided mould is connected with a resin source and a vacuum pump. The liquid resin infuses into the reinforcing fibres thanks to the vacuum drawn through the mould. Curing and de-moulding steps follow the impregnation process to finish the product.

The main steps of the process are:

- A dry fabric or preform and accompanying materials such as release films, peel plies are laid on tool surface.
- The preform is sealed with a vacuum bag and the air is evacuated by a vacuum pump.
- Liquid resin with hardener from an external reservoir is drawn into the component by vacuum.
- The liquid resin with hardener is infused into the preform until complete impregnation.
- Curing and de-moulding steps follow the impregnation to finish the product.

The components of the infusion process utilized in this work are illustrated in Figure 1. The function of the each component, given in the Figure, during manufacturing can be summarized as:

- Vacuum bagging films* are sealed to the edge of the mould with vacuum bag sealant tape to create a closed system.
- Double side bag *sealant tapes* are used to provide a vacuum-tight seal between the bag and the tool surface.
- Release films* are typically placed directly in contact with the laminate. They separate the laminate from the distribution medium. Release films are often perforated to ensure that any trapped air or volatiles, which may compromise the quality of the laminate, are removed.
- Release fabrics* and *peel plies* are placed against the surface of the laminate. They are woven products which are strong and have good heat resistance. Release films impart a gloss finish on the cured laminate, whereas peel plies and release fabrics leave an impression of the weave pattern. Peel plies provide a clean, uncontaminated surface for subsequent bonding or painting.
- Tool release materials* are used to release the product from tools easily and obtain a smooth surface finish. For this purpose, either self adhesive Teflon films or liquid release

agents are utilized. In certain situations Teflon films can also temporarily solve tool porosity problems.

- A highly permeable layer called "*resin distribution medium*" placed on the top of the preform spreads the resin quickly over the lateral extent of the part.
- Bleeder/breather* fabrics are non-woven fabrics allow air and volatiles to be removed from within the vacuum bag throughout the cure cycle. They also absorb excess resin present in some composite lay ups.

3. Automatic control of the (VARIM) system

The VARIM production system in this research consists of an 1800 mm x 1500 mm table capable of providing control of temperature and vacuum.

Electrical heating resistances are used for heating of table. The temperature control is achieved by means of acquiring temperatures using thermocouples located beneath the table surface. VARIM table is divided into eight regions. Each region has an independent closed loop temperature control system. By using a PLC and a touch screen, the system is capable of adjusting the desired temperatures, up to 200°C, and corresponding time intervals for curing cycles. The main advantage of using a PLC as a control unit for this system is to have a flexible control for changing the cure conditions.

Curing process is very important to produce composite parts with optimum mechanical properties. All regions in a composite part are supposed to be produced almost at the same curing conditions. So, a uniform temperature distribution through the heating table surface is of high importance. As mentioned before, the current VARIM system is of eight regions, each has a closed loop control, to achieve a constant temperature throughout tool surface. Thus, it becomes possible to control the heating resistances and hence the temperature distribution. Operator can easily program the cure cycle and temperatures using a man machine interface as can be seen in Figure 2. This Figure gives the block diagram of the control system. However, in this Figure, only temperature control system of Region 1 is shown to avoid repetition. The controller (PLC) of the VARIM system is programmed to send the realtime temperature values of all regions to the MMI and to a PC for data logging.

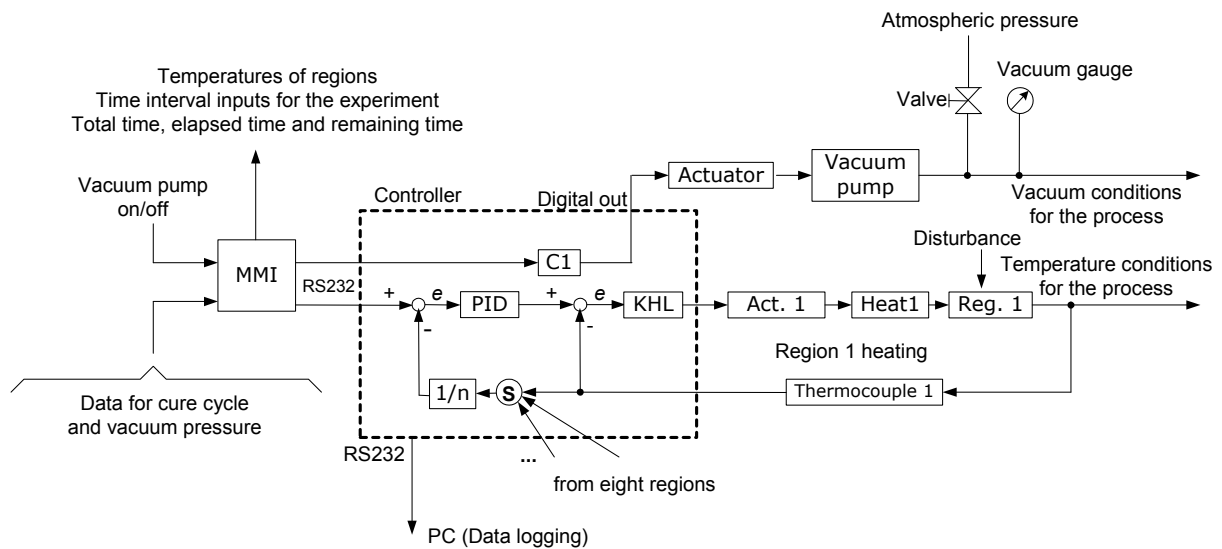

Fig. 2. Block diagram of the automatic control of the VARIM system

The control panel enables to set two or three temperature steps in a cure cycle. Figure 3(a) and (b) show schematic illustration of a cure cycle with two temperature steps and variation of vacuum versus time. Cure cycles are formed generally based on the instructions and recommendations of resin suppliers.

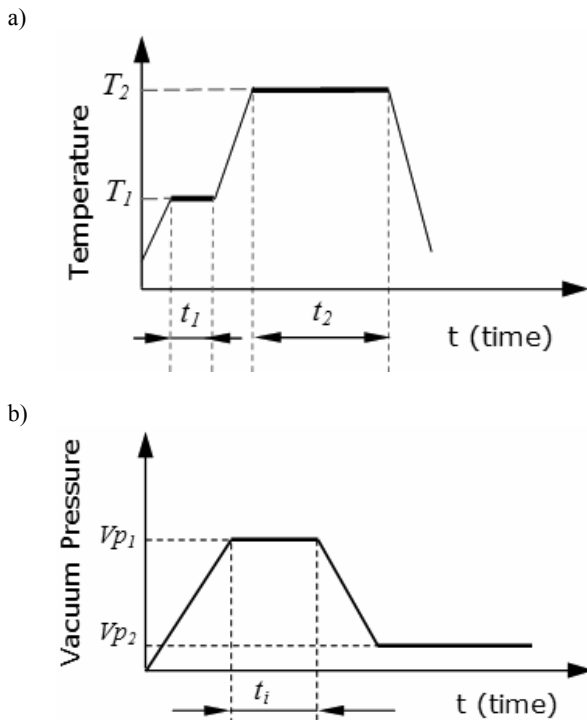

Fig. 3. The schematic diagrams of a cure cycle (a) and vacuum variation (b)

In the Figure, T_1 and T_2 stand for successive curing temperatures corresponding to the t_1 and t_2 time intervals while Vp_1 for the vacuum value during t_i time interval, time of resin infusion, and Vp_2 for the vacuum value applied throughout curing process.

In addition to temperature control system, the VARIM system is also equipped with a vacuum pump and a vacuum regulator with a vacuum gauge. The vacuum pump can be initialized and halted using touch screen. Vacuum value can be adjusted by the operator before or during the production. A number of parameters such as the permeability of the reinforcement stack, the resin viscosity and inlet geometry which may cause unpredictable cases or problems affects resin flow in the resin infusion moulding process and hence quality of the production. Therefore, the vacuum regulation system is included in PLC program as an open loop control. It enables to control vacuum manually during infusion moulding process.

By using the VARIM system, a number of high quality and void-free composite plates with different thickness and stacking sequences are fabricated. In Figure 4, fabrication of a composite plate is given.

4. Conclusions

An in-house Vacuum Assisted Resin Infusion Moulding (VARIM) setup has been developed for manufacturing of polymer matrix composites. Detailed information regarding this system is given in the paper. The setup is capable of controlling the level of vacuum pressure and the temperature of the heating table. Block diagram of the automatic control of the VARIM system is presented. With the function of each component used in vacuum infusion process, the main steps of the process are described. By using the VARIM system, high quality and void-free composite plates are fabricated.

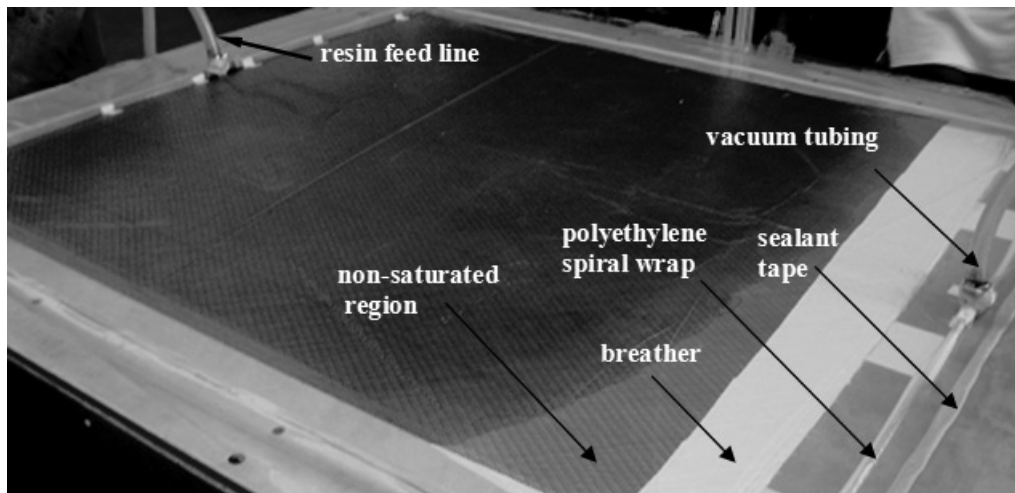

Fig. 4. A sample image of composite production by VARIM system

Acknowledgements

Authors would like to thank the MEGATEK Company, Manisa-TURKEY, for their helpful manner and collaboration during production of the VARIM system. The current VARIM system has been produced in scope of a TUBITAK project with number of 107M406.

References

- [1] J.W. Boh, L.A. Louca, Y.S. Choo, S.E. Mouring, Damage modeling of SCRIMP woven roving laminated beams subjected to transverse shear, *Composites B* 36 (2005) 427-438.
- [2] N.C. Correia, F. Robitaille, A.C. Long, C.D. Rudd, P. Simacek, S.G. Advani, Use of Resin Transfer Moulding Simulation to Predict Flow, Saturation and Compaction in the VARTM Process, *Journal of Fluids Engineering ASME* 126 (2004) 210-215.
- [3] M.K. Kang, W.I. Lee, H.T. Hahn, Analysis of Vacuum Bag Resin Transfer Molding process, *Composites A* 32 (2001) 1553-1560.
- [4] A. Khattab, Exploratory Development of VARIM Process for Manufacturing High Temperature Polymer Matrix Composites, Ph.D thesis, University of Missouri, 2005.
- [5] M.S. Koefoed, Modeling and Simulation of the VARTM Process for Wind Turbine Blades, Industrial Ph.D. Dissertation, Aalborg University, 2003.
- [6] A. Ragondet, Experimental Characterization of the Vacuum Infusion Process, PhD thesis, University of Nottingham, 2005.
- [7] D. Tzetzis, P.J. Hogg, Experimental and Finite Element Analysis on the Performance of Vacuum-assisted Resin Infused Single Scarf Repairs, *Materials and Design* 29 (2008) 436-449.