

Kazimierz Kopias,
*Zbigniew Kossowski

Department for Knitting Technology
and Structure of Knitted Fabrics
Technical University of Łódź
ul. Żeromskiego 116, 90-543 Łódź, Poland
E-mail: kopiaska@p.lodz.pl

*POLMATEX CENARO
Research Development Centre for Textile Machines
ul. Wólczajska, Łódź, Poland
E-mail: automatyka@cenaro.lodz.pl

Pneumatic Loom for Leno Weaves with Rotary Mechanism Forming the Shed and Beating-up the Weft

Abstract

We present herein a genuinely new concept for a rotary mechanism for pneumatic looms, which forms the shed and beating-up the weft, together with an electromagnetic device to drive the guide needle bar. The mechanism and device which we designed and constructed were tested using a model loom. The tests carried out indicated that the use of these machine parts increases the efficiency of looms which manufacture nets with leno weaves, significantly reduces noise generation by the loom, allows for weft inserting with the use of an air stream, and improves the energy balance of the loom.

Key words: weaving loom, leno weave, shed forming mechanism, weft beat-up mechanism, magneto-electric actuator, shed forming sinkers, rotary mechanism forming the shed and beating-up the weft.

shed, and is deflected by these sinkers onto one of the shed's branches. The second guide needle bar guides the remaining warp threads, which form the second shed branch, and directs them between the sinkers. After each weft insertion, the latter needle bar is displaced by one segment equal to the length of one graduation in the sinker displacements, in opposite directions alternately.

A modification [4] of the mechanism, which forms the shed of the loom with rotating sinkers, was made in order to introduce the weft by an air stream. The structure of this mechanism is presented in Figure 2.

The mechanism is provided with two rotating shafts, the upper (1) and the bottom (2) shaft. The shed forming sinkers (3) are mounted immovably to the upper shaft, alternately with the weft beat-up sinkers (4), which beat-up the weft (5) to the edge of the woven fabric (6). The distances between the shed forming sinkers are slightly greater than the sinkers' thickness. The sinkers (4) are placed at half the distance between the adjacent sinkers (3). Moreover, distance rings (7) are placed on the shaft (1) between sinkers (3) and (4). The shed forming sinkers (3) are mounted immovably to the bottom shaft (2) which is divided by distance rings (7). The distances between sinkers (3) mounted to the shaft (2) are also slightly greater than the sinkers' thickness. The sinkers (3) are mounted to the shafts (1) and (2) in such a way that the same fragments of the sinkers mounted to both of the shafts mutually coincide. The thicknesses of the sinkers (3) mounted to both shafts are equal. The sinkers (3) have the form of a circle seg-

ment. In each of the sinkers, a channel (8) with convergent walls is cut parallel to the circular part of their edges. The walls of the channels (8) of the sinkers (3) mounted to shaft 1 converge in the opposite direction to the walls of channels (8) of the sinkers (3) but mounted to shaft 2. The rotating shafts (1) and (2)

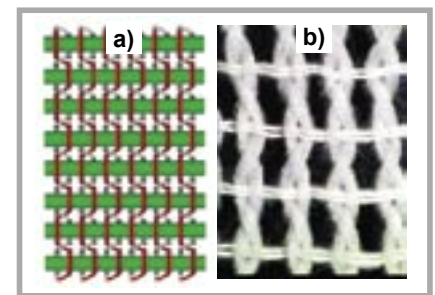

Figure 1. Drawing (a) and photo (b) of a leno weave.

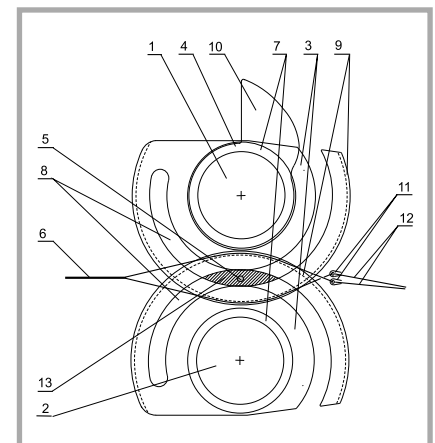

Figure 2. Scheme of the mechanism which forms the shed and beating-up the weft; 1 - upper rotating shaft, 2 - bottom rotating shaft, 3 - shed forming sinkers, 4 - weft beat-up sinkers, 5 - weft, 6 - woven fabric, 7 - distance ring, 8 - channel, 9 - groove, 10 - projection, 11 - guide needle bar, 12 - warp, 13 - convergent pipe.

Introduction

Woven fabrics with leno weaves [1] are characterised by a configuration of warp wherein adjacent warp threads are mutually interlaced between succeeding wefts (Figure 1).

Manufacturing such weaves with the use of traditional looms demands the use of special heald frame mechanisms of complex structure, which limit the efficiency of weaving.

In contrast, nets with leno weaves can be very easily and simply woven by using a loom with rotating sinkers which form the shed [2].

Rotary mechanism forming the shed and beating-up the weft

The weaving technology of woven fabrics with leno weaves [3] is based on the application of two guide needle bars. One of them is immovable, and positioned in such a way that each second warp thread that is guided by it is placed into the grooves of the sinkers which form the

are mutually situated so that the distance of their axes of rotation is equal to the sum of the outer and inner radii of curvature of the channels (8) of the sinkers (3). Moreover, a groove (9) of a depth about equal to the sinkers' thickness is cut in the circular part of the edge of each sinker (3). The weft (5) beat-up sinkers (4) have the shape of a ring with an outer radius smaller than the inner curvature radius of the channel (6) of sinkers (3). A projection (10) with a height slightly greater than the radius of the circular part of the sinkers (3) is mounted to the edge of each sinker (4). One edge of the projection (10) is an extension of the radius of the sinker (4), whereas the second has the shape of an involute developed from the outer edge of the sinker (4). The radius of the outer edge of the distance rings (7) is equal to the outer radius of the sinkers (4). The mechanism of the guide needle bars (11), the number of which depends on the kind of weave of the woven fabric to be manufactured, is placed near the sinkers (3) and (4) parallel to the axes of the shafts (10 and 2). Furthermore, the loom is equipped with a warp feeding mechanism (12) (behind which the backrest roller compensating for the changes in yarn demand is situated), a woven fabric (6) take-up mechanism, and the mechanism for introducing weft (5) into the shed.

Depending on the weave used for manufacturing the woven fabric, a part of the guide needle bars (11) is placed opposite to the sinkers (3) mounted to shaft (1), whereas the remaining part opposite to the sinkers (3) mounted to shaft (2). Thanks to this configuration, one group of warp threads (12) guided by one group of guide needle bars is inserted into the grooves (9) of the sinkers (3) mounted to shaft (1), whereas the second group of warp threads (12) guided by the second group of needle bars (11) is inserted into the grooves (9) of the sinkers (3) mounted to shaft (2). During the rotation of both shafts (1 and 2), the warp threads (12) of both groups part and form a shed. At the same time, the sinkers (3) mounted to the shaft (1) and the sinkers (3) mounted to the shaft (2) are mutually placed in such a way that their channels (8) form a common tunnel, which forms the convergent pipe, into which the weft (5) is inserted with the use of an injecting jet. During further rotating of both shafts (1 and 2), the weft (5) emerges from the convergent pipe (13), and with the help of the beat-up sinkers (4) is guided to the

edge of the woven fabric (6) and beat-up to it by the projections (10) of the sinkers (4). After taking up the formed fragment of the woven fabric (6), the sinkers (3) of both shafts (1 and 2) take a position with their right edges pointed mutually toward each other; in this position of the sinkers (3), the guide needle bars (11) are displaced along both the shafts (1 and 2) on a segment equal to the distance between sinkers (3), and next the cycle of shed forming is repeated, as well as the weft (5) insertion to the channel of the convergent pipe (13), and beating-up of weft (5) to the woven fabric edge (6).

When manufacturing a not with leno weave, two guide needle bars are sufficient. One of them threaded by each second warp thread is immovable, which causes that the threads guided by this bar to be placed in the sinkers' grooves mounted on one of the shafts. The second guide needle bar, threaded by the remaining warp threads, is displaced after each inserted weft at one graduation of sinker displacement, and inserts the guided threads into the grooves of the adjacent sinkers mounted to the second shaft.

The succeeding positions of the elements of the mechanism which forms the shed and beating-up the warp are presented in Figure 3.

The mechanism described which forms the shed and beating-up the warp was tested with the use of a model loom based on the P 125A jet pneumatic loom.

■ Functional loom model

The technological scheme of the P125A jet pneumatic loom is presented in Figure 4.

The loom is equipped with a warp beam (1) from which the warp is unwound. The warp on its way to the loom comes across the backrest roller (2), which ensures the appropriate tension of the warp threads. Next, the warp reaches the mails of the heald shafts. The harnesses (3) are driven by a crank mechanism. Depending on the kind of drive, which in turn depends on the weave of the woven fabric manufactured, the particular groups of harnesses are displaced over succeeding working cycles of the loom in one direction or the other. As a result of this movement the shed is formed, into which the weft is inserted by the device (4), which measure off the weft, and inject it with the use of



Figure 3. Succeeding positions of the elements of the mechanism which forms the shed and beating-up the warp.

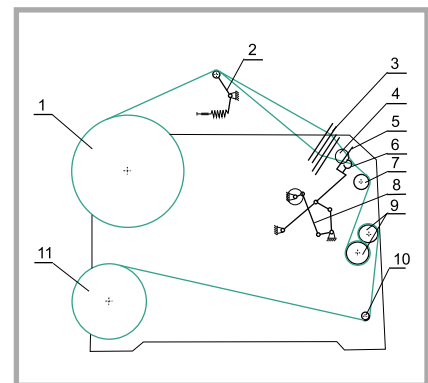

Figure 4. Technological scheme of P 125A jet pneumatic loom; 1 – warp beam, 2 – back rest roller device, 3 – harnesses, 4 – injecting device, 5 – reed, 6 – convergent pipe, 7 – back rest roller, 8 – crank mechanism, 9 – rake-up rollers, 10 – roller, 11 – woven fabric beam [11].

a compressed air stream. The convergent pipe (6) is used with the aim of ensuring the air stream from dispersion. The pipe and the reed are mounted to the batten, which is driven by the crank mechanism (8). The manufactured woven fabric encircles the fore-ring, is directed to the take-up roller (9), encircles the shaft (10), and is wound onto the woven fabric beam (11).

The modification of the loom described above was based on replacing the harness mechanism (3) and the reed (5) with the batten, and the convergent pipe (6) with the rotary mechanism discussed before. Furthermore, cogbelt transmissions driving the sinker-shafts were applied in the place of the crank mechanism used before (Figure 2), and an electromagnetic actuator [5] replaced the cam mechanism which displaces the guide needle cam.

Magnetolectric device for driving the guide needle cam

The magnetolectric actuator which was applied for driving the guide needle cam (11 in Figure 1) is presented in Figure 5. It was used together with a control system, a DC power pack, and a shaft position sensor.

The action of the actuator is based on the phenomena of generating forces, as the result of the influence of a magnetic field on a conductor through which electric current flows. A strong, stationary magnetic field generated in the air-gap by the set of magnets (2), pole shoes (3), and the jacket (4) influences the coil windings placed in the air-gap. A force is generated in the coil as the effect of current flow-

ing through the windings, and this force is transmitted by the carcass (6) onto the element driven, i.e. the guide needle bar. The value and the direction of the force generated can be controlled by the direction and value of the coil current.

The actuator's coil is connected to the control system. The aim of this is to control the coil current in such a way that the guide needle bar achieves its described position with an accuracy of 0.1 mm, and synchronises the movement of the cam with the movements of the sinkers so that the jump takes place at the technologically appropriate moment. The information of the sinkers' position is obtained thanks to the induction position sensor of the machine's driving shaft.

The electrical energy required to generate the motion demanded is provided by the DC power pack.

The basic technical parameters of the actuator designed by us and applied on the loom under discussion are as follows:

- supply voltage: 24V,
- working stroke of the actuator's mandrel: 5.5 mm,
- jump time: maximum 16 ms for a guide needle bar mass of 1.7 kg,
- maximum jumping frequency: 1000/min,
- maximum force generated: 300 N,
- obtaining accurate position.

Summary

The weaving experiments carried out with the use of the model loom we constructed indicated that both the applied concept of the mechanism for shed formation and beating-up the weft and the

device to drive the guide needle bar fulfil their intended functions satisfactorily.

Application of these devices leads to the following advantages:

- achieving an increase in the loom efficiency when manufacturing nets with leno weaves,
- significant reduction of noise generation,
- weft insertion by an air stream, and
- achieving a decrease in the energy balance of the loom.

Conclusions

The investigation presented above indicates that the proposed constructional solutions of the mechanisms forming the shed and beating-up the weft, as well as the guide needle bar driving system, should ideally be followed by manufacturing looms equipped with these devices, i.e. rotary shed forming mechanisms and electromagnetic actuators for guide needle cams. An analysis of this invention also indicates that possibilities exist to modifying the pneumatic looms used at present, as well as those which have been withdrawn from use.

Acknowledgment

This investigation was carried out as part of the research project 'Mechatronic model cam-sinkers system with rotating convergent pipe for weaving looms', number 5 T07C 01425, which has been fully sponsored by the Polish State Committee for Scientific Research (KBN).

References

1. Frontczak I., Wnuk J., 'Tkactwo', ed. WSiP, Warszawa, 1993.
2. Kopias K., 'Shedding with the Use of Rotating Sinkers and Needle Bars – A New Construction of the Loom', *Fibres & Textiles in Eastern Europe*, vol. 10, No. 2, 2002, p. 17.
3. Kopias K. et al., 'Method for manufacturing a woven fabric with leno weave and a device for manufacturing a woven fabric of leno weave (in Polish)', Patent Application P-352976, 2002.
4. Kopias K., Gwardyński M., Siejka B., 'Weaving loom with rotating sinkers forming the shed and beat-up the weft (in Polish)', Patent Application P-374626.
5. Kossowski Z., Kopias K., 'Drive for guide needle bars of a weaving loom (in Polish)', Patent Application P-368432, 2004.

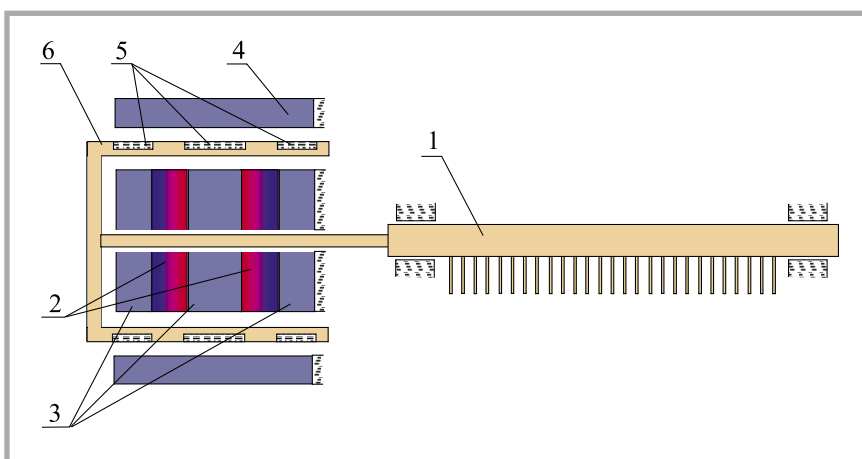

Figure 5. Scheme of the guide needle bar driving device; 1 – guide needle bar, 2 – set of magnets, 3 – pole shoes, 4 – jacket, 5 – windings of the coil, 6 – carcass.

Received 13.07.2005 Reviewed 07.11.2005