

# Revista Mexicana de Astronomía y Astrofísica

Revista Mexicana de Astronomía y Astrofísica  
Universidad Nacional Autónoma de México  
rmaa@astroscu.unam.mx  
ISSN (Versión impresa): 0185-1101  
MÉXICO

2005

C. Packham / C. M. Telesco / J. H. Hough / C. Ftaclas  
CANARICAM: THE MULTI-MODE MID-IR INSTRUMENT FOR THE GTC  
*Revista Mexicana de Astronomía y Astrofísica*, diciembre, año/vol. 024  
Universidad Nacional Autónoma de México  
Distrito Federal, México  
pp. 7-12

Red de Revistas Científicas de América Latina y el Caribe, España y Portugal

Universidad Autónoma del Estado de México



## CANARICAM: THE MULTI-MODE MID-IR INSTRUMENT FOR THE GTC

C. Packham,<sup>1</sup> C. M. Telesco,<sup>1</sup> J. H. Hough,<sup>2</sup> and C. Ftaclas<sup>3</sup>

### RESUMEN

La Universidad de Florida ha desarrollado una cámara de infrarrojo medio para el Gran Telescopio de Canarias de 10.4 metros, la cual está en sus etapas finales. CanariCam posee cuatro modos científicos y dos de ingeniería que emplean el mismo detector de banda de bloqueo de impurezas, de silicio adicionada de arsénico de 320 x 240 pixeles, de Raytheon. CanariCam representa una evolución del diseño exitoso de T-ReSC, para imagen/espectroscopía en el IR medio puesto en operación en el verano de 2003 en las instalaciones de Géminis Sur, que igualmente fue diseñado y construido en la Universidad de Florida. Cada uno de los modos puede ser rápidamente seleccionado a control remoto durante una secuencia observacional. La escala de pixeles es de 0.08 segarc, que corresponde a un muestreo de Nyquist de la función de dispersión limitada por difracción en 8 micras, la longitud de onda más corta para la cual está optimizada CanariCam. El campo visual total disponible para imágenes es de 26 segarc x 19 segarc. El modo primario de ciencia será de imagen limitado por difracción, con uno de varios filtros espectrales disponibles en las ventanas atmosféricas de 10  $\mu\text{m}$  (alrededor de 7.5-13.5  $\mu\text{m}$ ) y de 20  $\mu\text{m}$  (alrededor de 16-26  $\mu\text{m}$ ). Cualquiera de las cuatro retículas planas puede ser insertada para espectroscopía de rendija de resolución tanto baja como moderada ( $R = 60 - 1300$ ), en las regiones de 10 y 20  $\mu\text{m}$ . En la ventana de 10  $\mu\text{m}$ , la cámara se convierte en un coronógrafo mediante la inserción de diafragmas de campo y Lyot apropiados, mientras que la cámara se convierte en un polarímetro de doble haz mediante la inserción de una placa rotatoria interna de media onda, de una máscara de campo y de un prisma de Wollaston.

### ABSTRACT

The University of Florida is in the final stages of completing a mid-infrared camera for the 10.4-meter Gran Telescopio CANARIAS. CanariCam has four science modes and two engineering modes, which use the same 320  $\times$  240-pixel, arsenic-doped silicon, blocked-impurity-band detector from Raytheon. CanariCam represents an evolution of the successful instrument design of T-ReCS, the Gemini South facility mid-IR imager/spectrometer commissioned in summer 2003, which was also designed and built at the University of Florida. Each mode can be remotely selected quickly during an observing sequence. The pixel scale is 0.08 arcsec, resulting in Nyquist sampling of the diffraction-limited point-spread-function at 8 microns, the shortest wavelength for which CanariCam is optimized. The total available field of view for imaging is 26 arcsec  $\times$  19 arcsec. The primary science mode will be diffraction-limited imaging using one of several available spectral filters in the 10  $\mu\text{m}$  (around 7.5-13.5  $\mu\text{m}$ ) and 20  $\mu\text{m}$  (around 16-26  $\mu\text{m}$ ) atmospheric windows. Any one of four plane gratings can be inserted for low and moderate-resolution ( $R = 60 - 1300$ ) slit spectroscopy in the 10 and 20- $\mu\text{m}$  regions. In the 10  $\mu\text{m}$  window, insertion of appropriate field and Lyot stops converts the camera into a coronagraph, while insertion of an internal rotating half-wave plate, a field mask, and a Wollaston prism converts the camera into a dual-beam polarimeter.

*Key Words:* **INSTRUMENTATION: MISCELLANEOUS — INSTRUMENTATION: SPECTROGRAPHS — METHODS: OBSERVATIONAL**

### 1. INTRODUCTION

CanariCam is a state-of-the-art multimode camera being developed at the University of Florida for use at the Gran Telescopio CANARIAS (GTC). CanariCam will be operational in Winter 2004, and will be available for GTC Day-1 science observing. This

paper describes the camera and its key observational modes. CanariCams electronics are nearly identical to those of T-ReCS, the Gemini South mid-infrared camera, and the reader is referred to Telesco et al. (1998) for a more detailed description of them. CanariCam is optimized for use at 8-25 $\mu\text{m}$ , the so-called mid-infrared wavelength region, but it is useful for certain key engineering observations down to around 2 $\mu\text{m}$ . The goal has been to provide the GTC astronomical community with an outstanding workhorse

<sup>1</sup>University of Florida, Department of Astronomy, USA.

<sup>2</sup>Department of Physical Science, University of Hertfordshire, UK.

<sup>3</sup>Institute for Astronomy, Honolulu, Hawaii, USA.

multi-mode instrument for use in the atmospheric windows near  $10\ \mu\text{m}$  and  $20\ \mu\text{m}$ . The detector is an arsenic-doped silicon, blocked-impurity-band (BIB, or IBC) device from Raytheon, with peak QE in the  $8\text{--}25\ \mu\text{m}$  region and a rapid decrease in QE at longer wavelengths. In addition to the selection of this particular detector device, optimization for the mid-IR has entailed: (1) matching the plate scale of the instrument to the pixel size of  $50\ \mu\text{m}$ , so that the point-spread-function (PSF) is Nyquist-sampled at  $8\ \mu\text{m}$ , (2) selecting various window, filter and coating materials that maximize throughput at these wavelengths, (3) designing the electronics so that the detector can be read-out rapidly enough to prevent saturation in the high-thermal background that is characteristic of the mid-infrared regime, and (4) designing the cryostat to permit key components to operate below  $10\ \text{K}$  and (5) minimize background radiation from all extraneous sources.

Outstanding image quality, high throughput, and excellent mechanical stability are key characteristics of CanariCam. These properties must be achieved in the context of operational convenience, long-term reliability, and reasonable development and maintenance costs. As a facility workhorse instrument, CanariCam must possess a special combination of simplicity and outstanding performance. CanariCam will meet or exceed these expectations, and it is expected to be user-friendly to the GTC technical and astronomical staff who must support it.

CanariCam will address a broad range of key scientific areas. Astronomical bodies at temperatures of  $100\text{--}1000\ \text{K}$  emit significant mid-IR radiation. Of particular importance are the ubiquitous small dust particle that absorb radiation at virtually any wavelength and re-radiate it into infrared, sub-millimeter, or millimeter radiation. Mid-infrared continuum emission from the dust is diagnostic of the properties of a great variety of astrophysical objects, including planets, circumstellar disks, star-forming regions, and starburst and active galactic nuclei. With multi-wavelength mid-infrared imaging, one can locate energy sources that power often enormous luminosities, trace the distributions of dust particles and their temperatures, and determine how UV and optical radiation, which heats the dust, propagates throughout the infrared-emitting regions. The spectroscopy mode will permit investigations of the spectral energy distributions and emission lines from similar objects. The coronagraphic mode is ideally suited to the investigation of sub-stellar objects in close proximity to parent stars. Finally, polarimetric observations allow detailed mapping of the

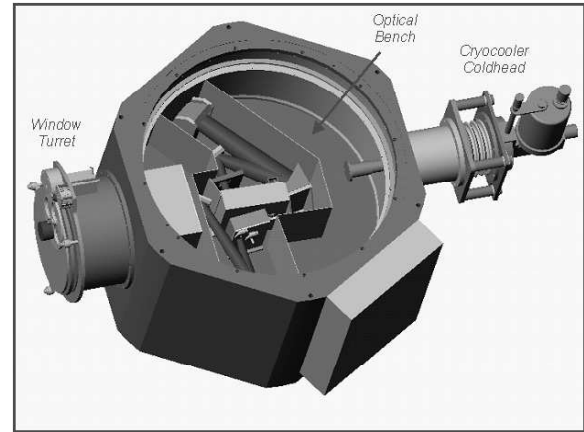

Fig. 1. The CanariCam enclosure, or dewar, illustrating its overall shape and scale and the locations of the coldhead, optical bench and window turret.

magnetic alignment of dust particles in objects such as circumstellar disks, young stars and active galaxies.

## 2. BASIC CONFIGURATION AND OPTICAL DESIGN

The CanariCam optics and detector are encased in a hexagonally shaped dewar to which is attached a coldhead capable of cooling the detector to its operating temperature of around  $9\ \text{K}$  and the optics and interior hardware to appropriately low temperatures to minimize thermal background. The CanariCam instrument is illustrated in Figure 1. The window-turret, permits one to select in real time from several entrance windows to permit optimization of the window material for specific science goals and humidity conditions. With the exception of the entrance window, the detector and all optical components and associated mechanisms are attached to the rigid internal optical bench, which is thermally isolated from the radiation shields and outer case by several bands, or cylinders, of G-10 fiberglass standoffs.

All of CanariCams powered and fold optics are reflective. The imaging and spectroscopic are fully reflective except for the entrance window and filters. The polarimetric mode employs a composite half-wave plate and a Wollaston prism, both of which are transmissive, and the coronagraphic mode uses an occulting spot located on a ZnSe substrate. The dominantly reflective design is achromatic and minimizes scattering and, therefore, straylight. The optics and mechanisms are distributed on both sides of the optical bench, with a fold, which diverts the beam through the bench. In the following descrip-

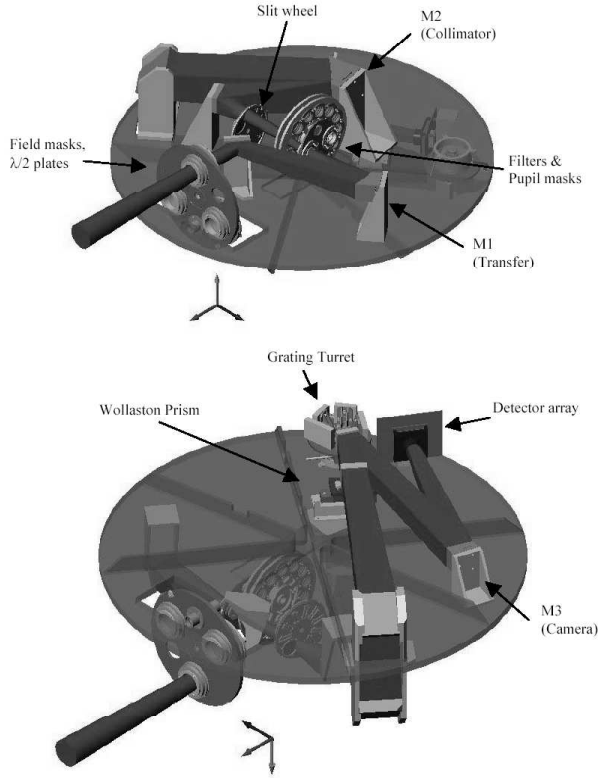

Fig. 2. The CanariCam optical layout shown attached to the optical bench.

tion we refer to Figure 2, which shows the optical bench and the associated optical components.

The telescope beam passes through the dewar entrance window and comes to a focus inside the dewar. Between the entrance window and the telescope focal plane, half-wave plates for the polarimetric mode or a lens assembly for the window-imaging mode can be inserted. The half-wave plates can be rotated to any position angle or one of four d-tent'd position angles. A selection of aperture stops (including occulting masks for coronagraphy and polarimetry as well as several test masks to confirm correct instrumental operation) are installed in a wheel at the location of the telescope focus. The diverging beam is then incident on the powered transfer mirror M1, which forms an image of the telescope pupil and an image of the telescope focal plane. Pupil stops are on a rotating assembly at the pupil image, and a double filter wheel is very close to this position. The rotating pupil stop assembly permits rotation of the complex pupil mask in order to provide maximum throughput and straylight rejection. One can insert a dual-lens assembly in this region to make pupil images. A slit wheel permits insertion at the re-imaged

telescope focal plane an open hole for imaging or a selection of spectroscopic slits for spectroscopy. The beam is then incident on the collimator M2, which forms a pupil image near the position where the gratings (for spectroscopy) and a flat mirror (for all other modes) are mounted on a rotatable turret. A Wollaston prism can be inserted into the collimated beam between M2 and the turret. After the turret the beam is incident on the camera mirror M3, which images the astronomical field onto the detector array.

### 3. OBSERVING MODES

Mid-infrared imaging is considered to be the fundamental science mode for CanariCam, and implementation of the other modes was prevented from compromising the imaging performance. The key image-quality requirement is that the energy enclosed within a square of pixels at the final image shall be at least 80% of that expected for the telescope alone at a wavelength of  $8\ \mu\text{m}$ . Even at this wavelength, the most aberrated part of the image plane delivers an enclosed energy that is 96% of the diffraction limit, corresponding to a Strehl ratio of 92%. The enclosed energies and Strehl ratios are higher for all other fields. The distortion of the field at the corner relative to the center is approximately 1 pixel. To achieve the highest possible throughput for a given set of observing conditions, the ferrofluidic window turret permits one to select from several entrance windows. For observing only in the  $10\ \mu\text{m}$  window, a ZnSe window is used which has a transmittance greater than 94%, but is opaque in the  $20\ \mu\text{m}$  window. For observing in both the  $10$  and  $20\ \mu\text{m}$  windows, a KBr window, for which the transmittance is greater than 92%, can be used. However, KBr is water-soluble, and so it cannot be used under higher-humidity conditions. Under such conditions a KRS-5 window will be used, albeit with a loss in throughput (transmission  $>70\%$  at  $2\text{-}35\ \mu\text{m}$ ). The throughput of the optical system (windows and mirrors only) is anticipated to be 90% with the ZnSe window and better than 85% with the KBr window. Including the detector and filters, the system throughput in the imaging mode is expected to be  $> 21\%$ .

The spectrometer follows that of the Czerny-Turner layout using any one of four classical plane gratings installed on a turret. The diameter of the pupil image near the grating has been maximized to achieve moderate spectral resolution, with the constraint that the system must fit within the envelope at the folded Cassegrain focus, which is the

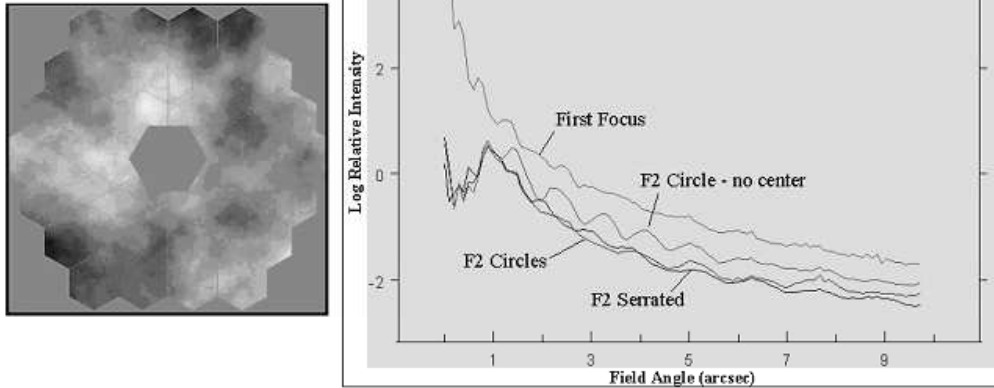

Fig. 3. The telescope pupil. Azimuthal PSF averages with and without the coronagraphic.

most constraining of the three focal-plane envelopes (Cassegrain, nasmyth, and folded Cassegrain) where CanariCam must be deployable. The resultant pupil image on the grating turret folding flat mirror is 24.4mm in diameter. The spectroscopy mode permits four modes of operation,  $10\mu\text{m}$  low resolution ( $R=175$ ),  $20\mu\text{m}$  low resolution ( $R=120$ ),  $10\mu\text{m}$  moderate resolution ( $R=1313$ ) and  $20\mu\text{m}$  moderate resolution ( $R=891$ ). The gratings are optimized for use in first order, although use in other orders is possible. Substrates will be aluminum and coated with protected gold. CanariCam will employ a slit wheel mechanism that permits the selection of any of nine slit with the use of an upstream dekker (i.e. oversized slit) in the aperture wheel. One will then be able to match the slit width to the seeing conditions or spectral resolution requirements during the observing session itself

CanariCam has a dual-beam polarimetric mode for the 10-micron spectral region (Packham et al. 2004), the first dual-beam polarimetry available for mid-IR wavelengths. The design permits simultaneous measurement of the ordinary (o) and extraordinary (e) rays, which minimizes effects of seeing and changes in atmospheric transparency and also increases observational efficiency (for compact sources). For a dual-beam polarimeter, an absolute uncertainty in the degree of polarization of 0.5% requires a S/N ratio of around 300:1 in total flux. For the source-limited case this corresponds to 80,000 photons or 40,000 per Stokes parameter. Thus, with a dual-beam system the accuracy obtained is a function of photon numbers only, and accurate polarime-

try of bright sources can be carried out during observing conditions that are too bad for almost any other type of quantitative observation. CanariCams polarimetric mode will be able to measure degrees of polarization as small as around 0.1% in the 10-micron atmospheric window. The key components of the polarimetric design are: (1) a cooled, rotatable (Sulphur-free) CdSe half-wave plate (HWP, retarder) within the cryostat located just upstream from the telescope focal plane; (2) a focal-plane mask at the telescope focal plane; and (3) a (Sulphur-free) CdSe Wollaston prism (analyzer) located just upstream from the grating turret. The HWP will be rotated sequentially to four (detent-determined) orientations (0, 22.5, 45, and 67.5 degrees), with images being taken at each HWP orientation. The Wollaston prism is inserted into the beam on a slide, and produces an angular separation between the orthogonally polarized states, hence producing two beams, the so-called o and e rays. Hence two images of the object are formed on the detector. The image quality is largely maintained with a small telescope focus change.

When using a dual-beam analyzer, a focal plane mask, is required so that extended objects can be observed without overlap of the orthogonally polarized images. The separation of beams is usually a compromise between possible optical aberrations produced for large separations and cross-talk for too small a separation. Large separations are convenient, since extended objects may be fully covered by one of the mask gaps, and observations can be made with a single pointing of the telescope.

For stars observed in the mid-IR, thermal background emission from the sky and the telescope will be many orders of magnitude larger than the stellar flux. By the use of chopping and nodding techniques, however, it is possible to remove this background at levels approaching one part in a million. Once the background has been removed, the focal plane intensity will be dominated by the stellar point spread function (PSF), the wings of which can be thought of as a halo arising from diffracted and scattered light. The key motivation for the coronagraphic mode is to suppress the stellar halo, or PSF wings, to allow circumstellar searches for disks and faint companions. An important goal of an effective coronagraphic mode is to minimize residual diffractive structure in the focal plane with minimum losses in field of view and throughput.

To illustrate key features of the CanariCam coronagraphic mode, we consider the case of good atmospheric conditions at an observing wavelength of 10 microns defined by a Fried scale length of order the size of the aperture (10 m) and an outer scale twice the size of the aperture (20 m). These parameters define Peak Atmospheric Conditions (PAC). The shape of the GTC entrance pupil with the model atmosphere is shown in Figure 3. We assume that the star is occulted in the telescope focal plane by a hard-edged (top-hat), low reflectivity circular mask occulting mask 0.83 arcsec in radius. In Figure 4 we show a plot of the log of the azimuthally averaged intensities as a function of the distance from the star. The top line represents the stellar image PSF for no coronagraphic masks. The line denoted F2 circle-no center represents the stellar image for the occulting mask and a circular Lyot stop inscribed in the hexagonal pupil. The line denoted F2-circles represents the stellar image for the occulting mask combined with a Lyot mask consisting of an inscribed circle and a central circular mask that blocks the central pupil obscuration. Finally, the line denoted F2 Serrated represents the stellar image for the occulting mask combined with a Lyot mask that has a serrated and hex-shaped outer mask that matches the pupil shape and masks that block the secondary-mirror spiders.

We have developed a design that employs a rotating Lyot stop and maximizes the throughput but provides some leeway for the operational complexity anticipated as the mask rotates. The basic design consists of: (1) a hard-edged (top hat), focal-plane (i0) mask 0.83 arcsec in radius; (2) a hard-edged, rotating Lyot stop with a spider mask with widths around 20 times the spider-image width. The rotating Lyot stop is dodecagonal (12-sided) and scaled

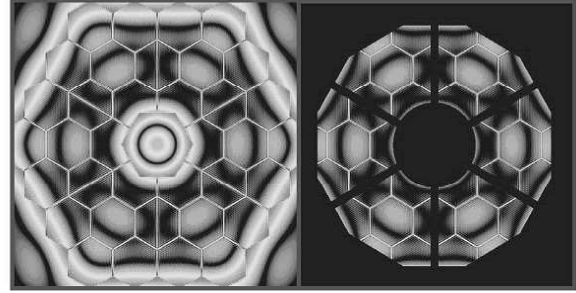

Fig. 4. Left: Pupil image after use of occulting spot at telescope focal plane. Right: Rotating pupil mask applied to pupil image.

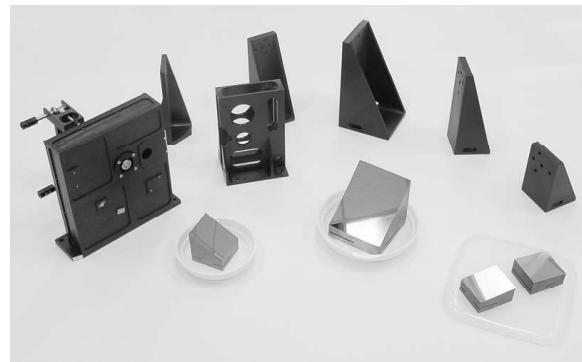

Fig. 5. Selected CanariCam Optics.

from the input pupil so that the outer dodecagonal edge is 90% the size of the image of the original. A central hard-edged, circular mask blocks out the secondary mirror/obscuration; that mask is 140% the size of the image of the original. The total throughput of the Lyot stop is 66%. The reason for the dodecagonal, rather than a hexagonal, mask is evident from Figure 4. In particular, the effect of diffraction is to make the image of the central obscuration more circularly symmetric and to make the hexagonal outer pupil edge appear softer, or more rounded. The proposed masks are intended to block more fully the unwanted radiation without reducing throughput unnecessarily.

#### 4. CURRENT STATUS

At the time of writing, CanariCam is in the integration phase where we will optimize and characterize the instrument. All optical components have been delivered to the University of Florida (see Figure 5), with the exception of the polarimetry optics which will undergo acceptance testing at the vendor shortly. Initial testing of the CanariCam optics on an optical test bench demonstrates the expected

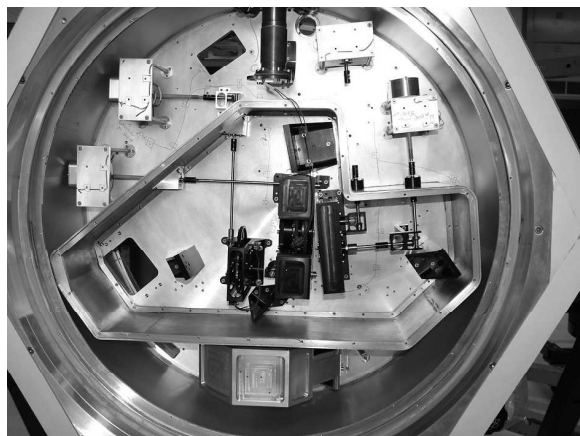

Fig. 6. Test fitting of mechanical components in CanariCam dewar.

optical quality. Testing of the efficiency of the diffraction gratings lead to rejection of the two moderate resolution gratings, which were subsequently remanufactured and retested to ensure they met their requirements. The filter suite includes five broad band filters and seventeen narrow band filters, most of which are part of the so-called VISIR filter consortium, the de-facto standard, which facilitates comparisons with other mid-IR instruments.

All cryogenic mechanical parts have been manufactured and the dewar, cold plate and G10 structure

is complete. All components have been test fit in the dewar, as shown in figure 6. The motor control box has been completed and tested on a motor test rig and demonstrated to operate as required. The pressure and temperature control boxes are complete, and the array read-out electronics and cabling are around 80% complete. The software effort is drawing heavily on the results of T-ReCS operation at Gemini South, and is around 85% complete.

Acceptance testing of CanariCam is scheduled for winter 2004, with the subsequent commissioning on the GTC to take place likely in 2006, dependant on the progress of the telescope commissioning. Detailed plans for the acceptance testing and commissioning of the instrument are in final preparation, drawing heavily on experience garnered from the success of T-ReCS on Gemini South. Finally, a science team consisting of Spanish/US-based astronomers is planning and making initial observations using Spanish/US-based observatories, to prepare for the advanced opportunities that CanariCam on GTC will provide.

#### REFERENCES

- Packham, C., Hough, J. H., Kolokolova, L., & Telesco, C. M., JQSRT 2005, in press  
 Telesco, C. M., Pina, R. K., Hanna, K. T., Julian, J. A., Hon, D. B., & Kisko, T. M. 1998, SPIE, 3354, 534

- C. Packham and C. M. Telesco: University of Florida, Department of Astronomy, 211 Bryant Space Science Center, Gainesville, FL, 32611 USA (packham@astro.ufl.edu).  
 J. H. Hough: Department of Physical Science, University of Hertfordshire, Hatfield, Hertfordshire, AL10 9AB UK.  
 C. Ftaclas: Institute for Astronomy, 2680 Woodlawn Drive, Honolulu, Hawaii, 96822 USA.