

Y. Selma SÜNGÜ<sup>1</sup>  
Birsen KARAMAN<sup>2</sup>  
E. Ferda PERÇİN<sup>1</sup>  
Sevim BALCI<sup>3</sup>  
İlhan SEZGİN<sup>1</sup>

## A Case of Bisatellited-Isodicentric Supernumerary Chromosome 15

<sup>1</sup>Department of Medical Biology and Genetics, Faculty of Medicine, Cumhuriyet University 58140-Sivas, <sup>2</sup>Department of Medical Genetics, Faculty of Medicine, Istanbul University, Çapa -Istanbul, <sup>3</sup>Department of Pediatrics, Faculty of Medicine, Hacettepe University Ankara - TURKEY

Received: August 28, 2000

**Key Words:** ESAC (extra structurally abnormal chromosome), bisatellite, isodicentric, marker chromosome

The frequency of extra structurally abnormal chromosomes (ESACs) is 0.2/1000 in live births and 0.6/1000 in midtrimester amniocentesis. The frequency is much higher (3.27/1000) in the mentally retarded population (1-5). Most ESACs (65%) are derived from chromosome 15 (6,7). About 16% of ESAC are familial. In general, familial ESACs have no impact on the phenotype. However, the risk prediction of de novo ESACs detected prenatally is difficult. This was estimated to be ~13% by Warburton (8). In those cases, the exact characterisation of the ESAC is very important. The conventional cytogenetic techniques such as GTG, CBG, RFA and NOR are not always helpful in solving this problem.

We report the cytogenetic findings of a case of ESAC, in which the GTG and CBG findings might lead to false diagnosis, if this chromosome were not familial (inherited).

### Case Report and Cytogenetics Studies

A phenotypically normal couple was investigated cytogenetically during second pregnancy because of a history of a child with neural tube defect that died immediately after the birth. GTG banded chromosome analysis of the couple revealed a normal karyotype in the mother, but an ESAC in all metaphases analysed (100 cells) in the father (Fig. 1a). Using CBG banding, a light coloured band was observed between two dark coloured

bands (Fig. 1b). Satellites on both sites of the ESAC were seen by NOR banding (Fig. 1c). An amniocentesis was performed. Fetal karyotyping indicated that the fetus was also a carrier for this ESAC (47,XY,+ idic. mar) (Fig. 2). Second level USG findings were normal and the pregnancy continued. In order to identify the origin of the ESAC, we used the FISH technique with Multiprobe 1 (Cytocell). The result showed that the ESAC originated from chromosome 15. Further findings of FISH application with the probes wcp 15 and SNRPN (Cytocell) indicated that the ESAC contained no euchromatic material. The karyotype was as follows:

47,XY,+idic.mar.lsh.idic(15)(15pter→q11::15q11→pter)[D15Z1++,SNRPN (PWS/ANG)-, wcp15. None of the other family members (II-4, III-1, III-3, III-7, III-9), (Fig. 3) who were investigated cytogenetically, had this marker chromosome.

Most ESACs are de novo in origin (9) and this may lead to a dilemma in prenatal diagnosis. The characterisation of ESACs is very important for risk prediction. It is generally accepted that ESACs containing euchromatic sequences lead to abnormal phenotypes. Soudek and Sroka (10) stated that C-banding is more informative than other conventional banding techniques for ESAC analysis. FISH techniques with different probes allowed us to define the origin and characterisation of ESACs. In our case, it was surprising to find such C-banding results in a normal carrier. However, the FISH results were found to be in agreement with the carrier



Figure 1a: GTG-stained metaphase chromosomes, showing the marker chromosome.

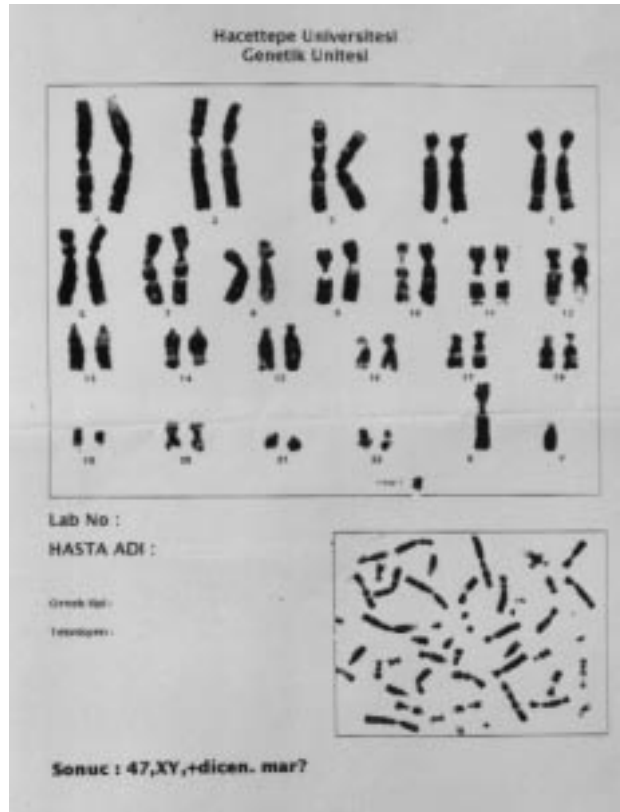

Figure 2. The karyotype following amniocentesis.

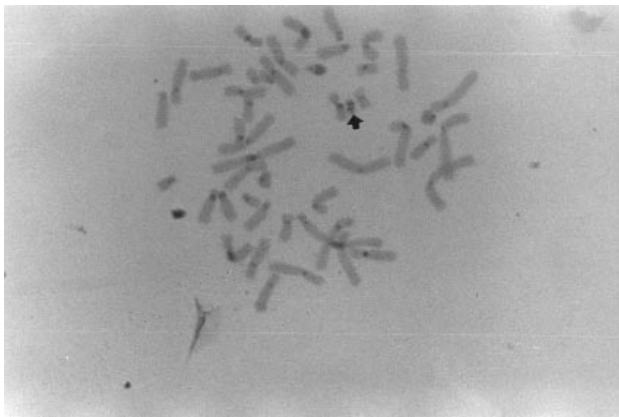

Figure 1b: CBG-stained metaphase chromosomes. (The arrow indicates the marker chromosome)



Figure 1c: Metaphase showing NOR banding. (The arrow indicates the marker chromosome)

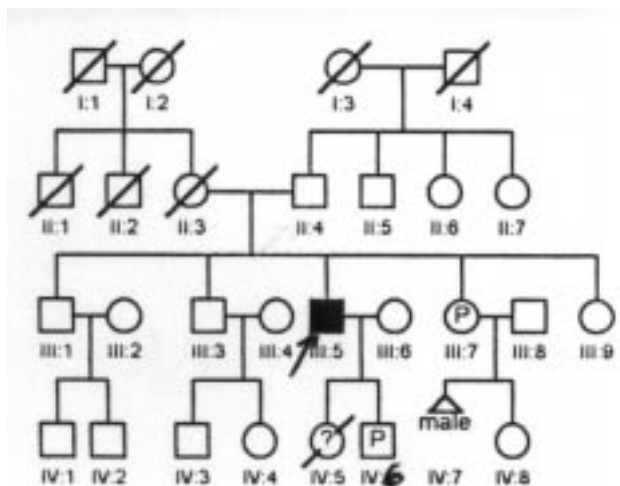

Figure 3. Pedigree of our case study.

phenotype. If this chromosome had been identified prenatally as de novo, the GTG and CBG results alone would have led to a false diagnosis. In such cases, FISH application is strongly recommended for the identification and characterisation of ESACs.

The family was recommended to have amniocentesis and genetic consultation for every pregnancy.

*Correspondence author:*

*Selma SÜNGÜ*

*Department of Medical Biology and Genetics,*

*Faculty of Medicine,*

*Cumhuriyet University 58140-Sivas - TURKEY*

## References

1. Adhvaryu GS, Brown PT, Livingstone E, Qumsiyeh BM. Familial supernumerary marker chromosome evolution through three generations (short communication) *Prenat Diagn* 18: 178-181, 1998.
2. Buckton KE, Spowart G, Newton MS, Evans HJ. Forty-four probands with an additional "marker" chromosome. *Hum Genet* 69 (4): 353-370, 1985.
3. Wolstenholme J, Burn J. The Application of Cytogenetic Investigations to Clinical Practice. In: *Human Cytogenetics* (Eds: DE. Rooney and BH Czepulkowski). 2<sup>nd</sup> Edn. Oxford University Press, pp: 119-156, 1992.
4. Hsu LYF. Prenatal Diagnosis of Chromosomal Abnormalities Through Amniocentesis. *Genetic Disorders and The Fetus* (Eds: A. Milunsky). 3<sup>rd</sup> Edn. Johns Hopkins University Press. Baltimore and London, pp: 155-210, 1992.
5. Mikkelsen M, Nielsen KB. Karyotype Analysis and Chromosome Disorders. In: *Prenatal Diagnosis and Screening*. (Eds: DYH. Brocks, HC. Rodeck, AM. Ferguson-Smith) Churchill Livingstone, pp: 99-125, 1992.
6. Sachs ES, Van Hemel JO, Den Hollander JC, Yahoda MG. Marker chromosomes in a series of 10000 prenatal diagnosis cytogenetic and follow-up studies. *Prenat Diagn* 26 (3): 621-628, 1987.
7. Crolla JA. FISH and molecular studies of autosomal supernumerary marker chromosomes excluding those derived from chromosome 15: II. Review of the literature. *Am J Med Genet* 75 (4): 367-381, 1998.
8. Warburton D. De novo balanced chromosome rearrangements and extra marker chromosomes identified at prenatal diagnosis: Clinical significance and distribution of breakpoints. *Am J Hum Genet* 49 (5): 995-1013, 1991.
9. Hook EB, Schreinemachers DM, Willey AM, Cross PK. Rates of mutant structural chromosome rearrangements in human fetuses: Data from prenatal cytogenetic studies and associations with maternal age and parental mutagen exposure. *Am J Hum Genet* 35 (1): 96-109, 1983.
10. Soudek D, Sroka H. C-bands in seven cases of accessory small chromosomes. *Clin Genet* 12 (5): 285-289, 1977.