

Revista Mexicana de Astronomía y Astrofísica  
Universidad Nacional Autónoma de México  
rmaa@astroscu.unam.mx  
ISSN (Versión impresa): 0185-1101  
MÉXICO

2007

M. L. Edwards / S. S. Eikenberry / A. Marín Franch / M. Charcos Llorens / M. Rodgers / J. Julian / S. N.  
Raines / C. Packham

STATUS OF THE CANARIAS INFRARED CAMERA EXPERIMENT (CIRCE)

*Revista Mexicana de Astronomía y Astrofísica*, vol. 029

Universidad Nacional Autónoma de México

Distrito Federal, México

pp. 21-23

Red de Revistas Científicas de América Latina y el Caribe, España y Portugal

---

Universidad Autónoma del Estado de México

<http://redalyc.uaemex.mx>



## STATUS OF THE CANARIAS INFRARED CAMERA EXPERIMENT (CIRCE)

M. L. Edwards,<sup>1</sup> S. S. Eikenberry,<sup>1</sup> A. Marín-Franch,<sup>1</sup> M. Charcos-Llorens,<sup>1</sup> M. Rodgers,<sup>2</sup> J. Julian,<sup>1</sup> S. N. Raines<sup>1</sup>, and C. Packham<sup>1</sup>

### RESUMEN

El experimento Cámara (CIRCE) es un instrumento visitador para el infrarrojo cercano para el Gran Telescopio de Canarias (GTC) de 10.4-m. Además de su funcionamiento como un formador de imágenes de 1-2.5 micrones, CIRCE tendrá la capacidad para obtener imágenes de banda angosta, espectroscopía de grisma de baja y moderada resolución, y polarimetría. El diseño óptico asférico totalmente reflectivo de CIRCE ofrece un excelente rendimiento y calidad de imagen. Presentamos un análisis del diseño óptico, revisión del desarrollo del software y el progreso del diseño opto- y crio-mecánico y de la manufactura.

### ABSTRACT

We report on the design status of the Canarias InfraRed Camera Experiment (CIRCE), a near-infrared visitor instrument for the 10.4 meter Gran Telescopio Canarias (GTC). In addition to functioning as a 1-2.5 micron imager, CIRCE will have the capacity for narrow-band imaging, low- and moderate- resolution grism spectroscopy, and polarimetry. CIRCE's all-reflective aspheric optical design offers excellent throughput and image quality. We present an analysis of the optical layout, an overview of the software development and the progress of the opto- and cryo-mechanical design and manufacture.

*Key Words:* **INFRARED: GENERAL — INSTRUMENTATION: PHOTOMETERS**

### 1. INTRODUCTION

The Canarias InfraRed Camera Experiment (CIRCE) is a near-infrared (1-2.5  $\mu\text{m}$ ) instrument for the Gran Telescopio Canarias (GTC) 10.4-meter telescope. While several instruments will be immediately available upon completion of the telescope, EMIR, the near-infrared facility instrument, will not be on-line until after the GTC's inception. We designed CIRCE to observe the currently uncovered wavelength range and fill the gap between first and second generation instruments. Furthermore, features such as narrowband imaging and polarimetry will allow CIRCE to fill important niches once EMIR is complete, augmenting CIRCE's role as a complement to the facility instrument suite.

CIRCE has an all-reflective aspheric optical design that offers excellent throughput and image quality. We first offer the results of our analysis of the optical layout and then discuss the design of opto- and cryo- mechanical components including the mirrors, brackets, and filter wheels. We end with a brief overview of software and hardware development.

<sup>1</sup>University of Florida, Department of Astronomy, 211 Bryant Space Science Center, Gainesville, FL 32611, USA (edwards@astro.ufl.edu).

<sup>2</sup>Optical Research Associates, 3280 East Foothill Boulevard, Suite 300 Pasadena, CA 91107-3103, USA.

### 2. INSTRUMENT DESCRIPTION

CIRCE will be a cryogenic re-imager with a standard collimator/camera design similar in its basic layout to most modern astronomical infrared cameras, including the Wide-field InfraRed Camera (WIRC) (Wilson et al. 2003) and FLAMINGOS-2. However, CIRCE differs significantly from the instruments in its all-reflective optical system using diamond-turned aspheric mirrors. This approach is a natural step in the development of similar diamond-turned complex aspheric systems for use in astronomical applications at the University of Florida, including the GTC facility mid-infrared imager/spectrograph (CanariCam) and the new near-infrared image-slicing integral-field spectrograph (FISICA). Such an optical approach provides significantly improved image quality and throughput as compared to more traditional refractive designs. While diamond-turned aspheres have been historically difficult to test and align, there have been significant advances in their manufacture and testing over recent years. The University of Florida has considerable experience in handling and aligning them within the necessary tolerances for the above-mentioned instruments, providing confidence that we can implement the CIRCE design successfully.

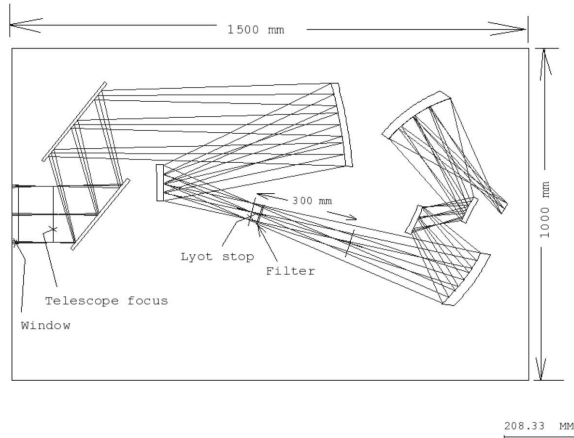

Fig. 1. The all-reflective aspheric optical design of CIRCE.

Figure 1 illustrates the basic components of CIRCE. Incoming light from the telescope will pass through the cryostat entrance window, inside of which all components will be kept at temperatures of 77K to eliminate contaminating thermal near-infrared emission. At the telescope focus, CIRCE will have a “slit wheel”, including an imaging field stop ( $3.4 \times 3.4$ -arcmin), a long slit for grism spectroscopy, and a partial-field imaging stop for Wollaston polarimetry. After the telescope focus, two fold mirrors compress the design into the necessary envelope requirements. Then a 2-mirror collimator will produce an image of the telescope exit pupil at a Lyot stop, which blocks stray light from reaching the detector. CIRCE will have two filter wheels fore and one aft of the Lyot stop, placing bandpass filters (both broad- and narrow- band) in the collimated beam, allowing the study of the infrared colors and emission features of science targets. After the filter wheel, a 4-mirror anastigmatic camera will bring the light to a focus on the HAWAII-2  $2048 \times 2048$ -pixel infrared detector.

CIRCE spectroscopy includes two grisms, both of which are derived from designs for the FLAMINGOS-2 instrument for Gemini (and share the grating ruling masters custom-built for FLAMINGOS-2). The first grism will cover the  $1.25 - 2.4\mu\text{m}$  bandpass instantaneously at a resolution of  $R=410$  at  $1.25\mu\text{m}$  and  $R=725$  at  $2.20\mu\text{m}$  (all resolutions are FWHM for a 3-pixel slit). The second grism will cover a single band instantaneously at a resolution of  $R \sim 1500$  (3-pixel slit) in its 3rd order (K-band), 4th order (H-band), or 5th order (J-band). The CIRCE optics will maintain seeing-limited image quality with the

grism in the optical path over the entire bandpass.

In addition, CIRCE’s optical design includes a polarimetric mode. A detailed explanation of CIRCE’s polarimetric capabilities are the subject of another paper in these proceedings.

### 3. CURRENT PROGRESS

#### 3.1. Optical Design

We concluded the primary optical design phase, including a slight modification to the initial concept that compressed CIRCE into the envelope size specified for the Bent Cassegrain Port of the GTC. We then proceeded with a detailed analysis of the current layout. Using an enclosed energy diagram, we find that throughout most of the field, CIRCE reaches enclosed energy values  $> 80\%$  in the J-band. Even at the corners, one 18 micron pixel contains  $\sim 70\%$  of the light from a point source. The 0.10 arcsec plate scale will provide seeing limited images even in excellent atmospheric conditions; preliminary models suggest that it will produce images with  $< 0.25$  arcsec intrinsic FWHM. Also, the planned  $3.4' \times 3.4'$  field is 25 times larger than NIRC/KECK and 3 times larger than NIRI/Gemini.

Once we finished the optical layout and analysis, we began work on the mechanical designs necessary for manufacture of the mirrors. We completed 2-D drawings of the optics using AutoCAD and submitted them to several manufacturers for review.

A unique and specialized solution to optical testing surfaced in our discussion with Janos Technology. Instead of testing each optic separately to ensure that it is within specification, Janos will test the entire system in concert. This novel technique encompasses the bench, bracket, and mirrors, and allows for immediate correction of alignment problems *in situ*.

We began 3-D designs of the eight CIRCE mirrors and brackets and the  $1.5 \text{ m} \times 1 \text{ m}$  optical bench. Using techniques previously employed in the design of other successful University of Florida instruments, we modeled the optical surfaces and locations with AutoCad and used this template to create the correct hole patterns for mirror blocks, brackets, and bench. Furthermore, to decrease the weight of the optics, we lightweighted the more massive mirrors using a honeycomb technique that will reduce the weight of the mirrors by up to 25%.

The brackets and mirror blanks are currently in production at the University of Florida. We expect delivery of all critical pieces to Janos and return of the mounted brackets and mirrors within the next six months.

Since the goal of CIRCE is to design, build, and integrate a powerful and useful instrument in a short amount of time, we chose to draw from the proffered expertise and skill of other instrumentation teams at the University of Florida. We used cryostat designs from both FLAMINGOS-1 and FLAMINGOS-2 as the basis for the CIRCE cryostat. Similarly, we modeled the CIRCE filter, grism, and lyot wheels and filter box after the FLAMINGOS-2 design. This design philosophy will also ensure the efficiency of all cyro-mechanical component production.

The CIRCE filter box will hold five geared wheels. Of the five wheels, three will contain narrow- and broad- band filters. Each filter wheel will hold five filter cartridges designed for 70 mm-diameter, 6 mm-thick circular filters. These cartridges will ensure that disassembly of the filter box will not be necessary to remove and insert filters. While this will allow for simple exchanges during cryostat warm-ups, CIRCE's 12 filter capacity should meet the nightly needs of most observers. The design of the grism wheel, positioned at the aft of the filter box, is similar to that of the filter wheels. The grism wheel will house four grism cartridges with one "open" space for use when CIRCE is in imaging mode. While the lyot wheel is identical to the filter wheels, its specialized cartridges will allow us to tilt masks in the lyot stop to meet CIRCE's optical design specifications.

We finished design of the filter box and wheels and manufacture will soon be underway. We currently have the filter, grism, and lyot gear blanks in-hand. Upon completion, we will test each cryo-mechanism prior to integration using a specially designed test cryostat available at the University of Florida.

The CIRCE slit wheel at the telescope focal plane offers a new challenge. The envelope specifications place specific limitations on the slit wheel design. To overcome these constraints, we are currently studying several options, including a decker wheel and slit "fan". We will continue to explore these concepts in the coming months and expect design completion before the return of the optical bench.

#### 4. HARDWARE

CIRCE's control hardware consists of four physical units: the Cryostat housing the detector array, optics, and mechanisms, the Detector Control (DC) hardware (MCE3+ Array Controller), the Mecha-

nism Control (MC) hardware, and the Local Control Unit (LCU) that runs the control and data transport software.

All described subsystems will be controlled through the UFLIB instrument control software. The UFLIB software is specifically designed to interface with MCE array- and mechanism-controller electronics, and will thus allow a straightforward implementation of the instrument control (based on FLAMINGOS-1).

#### 5. USER INTERFACES SOFTWARE

The user interface will consist of two java-based interfaces: UFJCI for the mechanism and detector control and UFJDD for quick look and analysis of data.

The UF Java Control Interface (UFJCI) is a Graphical User Interface that communicates with device agents and will allow an observer to configure, start, and monitor an observation with CIRCE. The UFJCI can be executed on any machine with TCP/IP access to the instrument's LCU, and so is usually not running on the LCU.

The UF Java Data Display (UFJDD) communicates with the FAS for fetching and displaying current status and data frames for quick-look display purposes. It will allow an observer to display, process, and analyze the data.

A more complete description of CIRCE software and hardware can be found in Marín-Franch et al. (2006)

#### 6. CONCLUSION

The Canarias InfraRed Camera Experiment will provide a unique and powerful complement to the GTCs facility instruments. We expect that CIRCE, with its imaging, spectroscopic and polarimetric modes, will produce a myriad of scientific results.

We would like to acknowledge the support of the University of Florida, the Gran Telescopio Canarias Project Office, the Elmer team, the EMIR team, and the National Science Foundation

#### REFERENCES

- Wilson, J. C., et al. 2003, Proc. SPIE, 4841, 451  
 Marín-Franch, A., et al. 2006, Proc. SPIE, 6269, 155