

Hikmet HASSA¹
Ömer T. YALÇIN¹
Nilgün BASMAK¹
Hamza ESEN²
Duygu KOYUNCU³
Nevin KURTDERE⁴
Resat N. ASTI⁴

Teratogenic Effects of Electromagnetic Fields on the Skeletal Systems of Rat Fetuses

Received: March 10, 1998

Abstract: OBJECTIVE: To evaluate the potential teratogenic effects of electromagnetic fields on the skeletal systems of rat fetuses.

MATERIAL AND METHODS: Twenty-five pregnant rats, which had been exposed to electromagnetic fields with frequencies of vertical 50 Hz and horizontal 20 kHz and a total maximum intensity of 10 milligauss, during their pregnancies, were the study group, while 15 pregnant rats were the control group. One hundred eighty-nine and 125 fetuses obtained from the study and the control group respectively, were evaluated for abnormalities and variations in the skeletal system. The chi-square test was used for the statistical analysis.

RESULTS: Major abnormality, minor abnormality and variation of the skeletal

system were seen in 4(16.0%), 3(12.0%) and 12 (48.0%) of the 25 litters and 8(4.2%), 4(2.1%), and 41 (21.7%) of the 189 fetuses respectively, in the study group, while none of the litters or fetuses had any abnormalities and 2 litters (13.3%) including 5(4.0%) fetuses had variations of the skeletal system in the control group. The proportions of the litters ($p<0.05$) and fetuses ($p<0.01$) with skeletal system variation in the study group were found to be significantly higher than the proportions of those in the control group.

CONCLUSION: Electromagnetic fields created by video display terminals might alter the normal development of the skeletal systems of rat fetuses.

Key Words: Electromagnetic field, rat, skeletal system, teratogenic effect.

¹Departments of Obstetrics and Gynecology, Osmangazi University, Faculty of Medicine, Eskişehir.

²Biophysics, Osmangazi University, Faculty of Medicine, Eskişehir.

³Histology and Embryology, Osmangazi University, Faculty of Medicine, Eskişehir.

⁴Department of Histology and Embryology, Ankara University, Faculty of Veterinary Medicine Ankara-Turkey

Introduction

A standard video display terminal (VDT) creates a very low frequency electromagnetic (EM) field with a maximum intensity of 2 milligauss approximately 30 cm from the screen (1-3). The rapid increase in the number of VDTs used in the working environment together with the number of women working during their reproductive periods have resulted in an increase in the number of pregnant women using VDTs during pregnancy (4-6). For this reason, the question of whether the EM fields created by VDTs have any potential teratogenic effects or not, has occurred during the last half century (1-7).

Although some epidemiological studies, designed to answer this question, found that some types of abnormalities were seen more frequently in the children of women who had operated VDTs during their pregnancies compared to those who had not, there were

no statistically significant differences between the two groups (1-3, 5-8). Almost all of the studies reported significantly increased rates of growth retardation in animal fetuses exposed to EM fields. However, there were controversies about its teratogenic effects (9-17). Some studies found that some types of abnormality, especially those of the skeletal system occurred significantly more frequently with exposure to EM fields and the teratogenic effect increased with increasing amount and frequency of the EM fields (9, 12-14, 16), while others reported that only the risk of skeletal system variations increased significantly but the risk of abnormalities did not (11, 15, 17).

This study was designed to evaluate the teratogenic effect of EM fields, which had similar intensities and frequencies to those created by a standard VDT on the skeletal systems of rat fetuses.

Materials and Methods

Forty 3-month-old adult female Wistar albino rats were used in this study, which was designed by the departments of Gynecology and Obstetrics, Histology and Embryology and Biophysics and was performed in Physiology laboratory. The reproductive cycles of every rat, which were kept in wooden cages at room temperature, were followed for 15 days. Every female rat determined to be in estrus or proestrus phase of their cycles were mated polygamously with male rats in the same cage for one day and those which had sperm in their vaginal smears were considered to be at the day zero of their pregnancies.

Fifteen of the 40 pregnant rats which were kept in a simple wooden cage without any EM field exposure during the study, were the control group. The remaining 25 pregnant rats in the study group were kept in a specially constructed wooden cage in which the EM fields with desired intensities and frequencies were created by two pairs of Helmholtz coils (Figure 1). One of these coil pairs was placed horizontally on the external surfaces of the ceiling and floor of the cage to create the vertical and other pair was placed vertically on the external surfaces of two lateral walls to create horizontal EM fields (3). Each pair of coils was connected to two different function generators which supplied alternate current to adjust the frequencies of the vertical and horizontal EM fields as 50 Hz and 20 kHz, respectively. The desired intensities of each EM field was obtained by adjusting the intensities of alternate current through the coils, so that the intensities of EM field to which the rats were exposed was 10 milli Gauss (mG) peak for each pair. The peak EM field at the center of each pair of circular coils placed a known distance apart was calculated by using the equation:

$\beta = [4\pi \cdot 10^{-7} \cdot I \cdot a \cdot N / (a^2 + z^2)^{2/3}]$ where β was the intensity of EM field, I was the intensity of current through the coils, a was the radius of coil, N was the number of turns on each coil and z was the distance between each pair of coils (1-3). Twenty-five pregnant rats in the study group were exposed to these EM fields 8 hours per day during the first 20 days of their pregnancies. Apart from exposure to EM fields, similar conditions with respect to the food and water supplies, humidity and temperature of the cages, were provided for all the pregnant rats in both groups.

All of the pregnant rats were sacrificed by cervical dislocation on the 20th day of gestation and fetuses were removed from the uterus by laparotomy and hysterotomy. One hundred eighty-nine and 125 fetuses obtained from the study and the control group respectively, were first examined macroscopically for gross structural abnormalities by the same researcher who was unaware of the type of fetus. Samples of cartilage and bone tissues were taken from the upper right carpal joints of 10 randomly selected fetuses from each group by another researcher. These samples were fixed in 4.0% glutaraldehyde solution and prepared for electron microscopic examination to evaluate the maturation of cartilage and bone tissues. Including these ones, all of the fetuses were fixed in 96% ethanol and their soft tissues were removed in 1.0% KOH solution. After staining with the Alizarin Red-S and/or Alcian blue-Alizarin Red-S combined technique, they were examined under a light microscope by a histologist (18). The teratogenic effects observed in the fetuses were categorized as major abnormalities, minor abnormalities and variations. Nonsynchronized developments of the tissues were accepted as variations. Abnormalities which

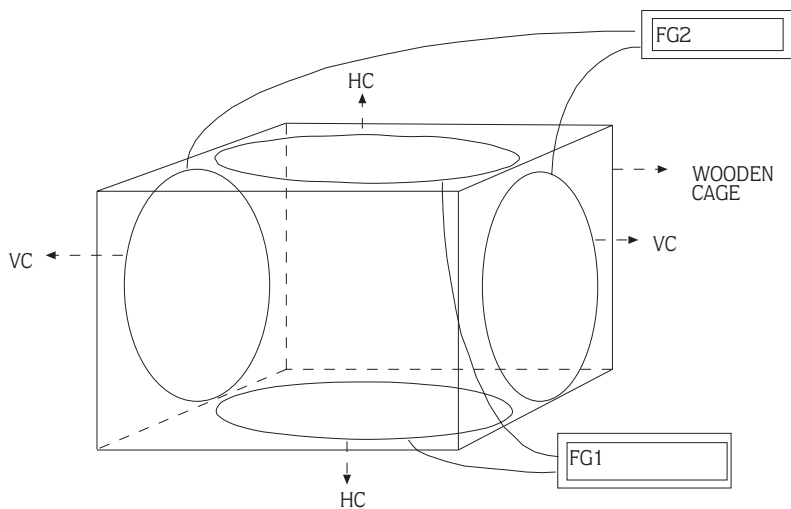

Figure 1. Diagram of the specially constructed wooden cage in which the electromagnetic fields created by two pairs of Helmholtz coils (HC: Horizontal Coils, VC: Vertical Coils, FG: Function Generator).

did not affect the function of organs or systems were counted as minor, while those which were believed to effect the functions or to be lethal for fetuses were categorized as major abnormalities (10, 15, 16).

Data obtained from the study and the control groups were compared statistically by using the chi-square test.

Results

None of the litters and fetuses in the control group had any major or minor abnormality of any system. However, 2(13.3%) litters including 5(4.0%) of the 125 fetuses had a total of 7 variations in the skeletal system. Four of these 7 variations were ossification retardation of the sternbrae, while two of them were ossification retardation of the basis crania and one of them was asymmetric ossification of the xyphoid.

Eight (4.2%) of the 189 fetuses in the study group had a total of 12 major abnormalities and 4 (2.1%) of them had a total of 4 minor abnormalities, while 41(21.7%) of them had a total of 57 variations in the skeletal system. The numbers of litters including fetuses with major abnormalities, minor abnormalities and variations in the skeletal system were 4 (16.0%), 3 (12.0%) and 12 (48.0%) respectively, in the study group. One fetus with a major skeletal system abnormality (phocomelia) had also two different major abnormalities of the gastrointestinal system (macroglossia and megacolon). Twelve major skeletal system abnormalities included 5 syndactylies, two short and curved tails, one segmentation deformity of the tarsal bones, one spacious angulation of the radioulnar joint, one atrophic extremity, one hand at the crus and one phocomelia. Four minor skeletal system abnormalities included three enlarged anterior fontanel and one enlarged posterior fontanel. Twenty-six, 21 and 10 of the 57 variations of the skeletal system were ossification retardation of sternbrea, ossification retardation of basis crania and ossification retardation or unossification of xyphoids, respectively. Light microscopic examinations of the fetuses showed that almost all of the abnormalities and variations of the skeletal system included incomplete ossification and segmentation of the bone tissues and very narrow joint distances. As the control group had no abnormalities, a statistical comparison could not be done between the rates of major or minor abnormality on the two groups. However, both the proportion of the litters ($p<0.05$) and the proportion of the fetuses ($p<0.01$) with skeletal system variations in the study group were found to be significantly higher than the proportions of those in the control group.

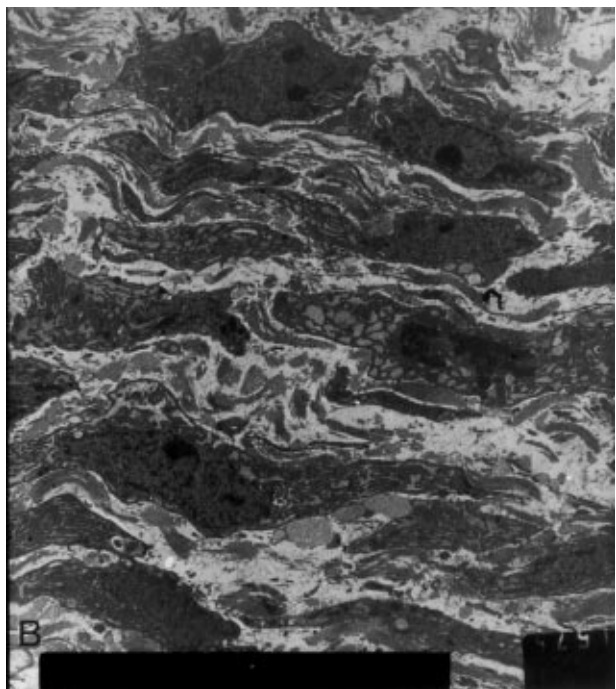
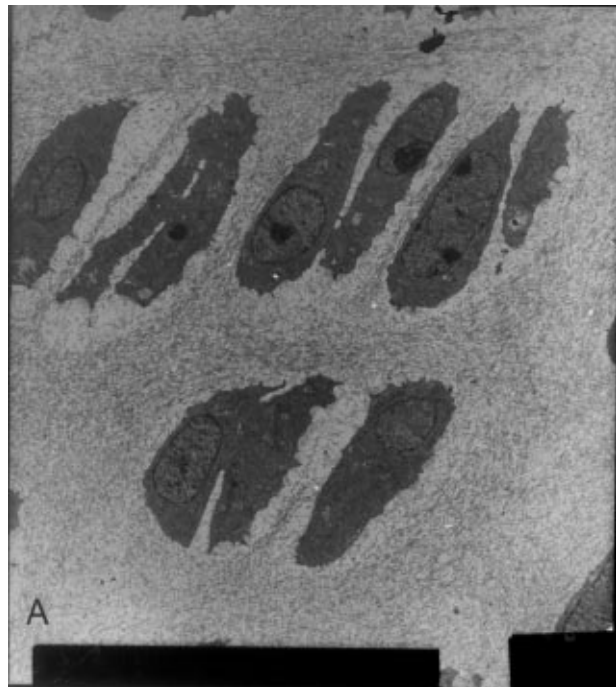

Figure 2. A) Normal proliferation cartilage containing mature chondrocytes, B) Abnormal proliferation cartilage containing undifferentiated mesenchymal cells. EM, x7200.

During electron microscopic examination, 7 of the 10 samples taken from the study group were observed to have insufficiently proliferated immature cartilage tissues, which still contained a significant amount of mesenchymal cell (Fig. II-B). However, this finding, which was accepted as evidence of maturation retardation of cartilage tissue, was observed only in 2 of the 10 samples taken from the control group, while the remaining 8 samples had completely differentiated cartilage tissues containing mature chondrocytes (Fig. II-A). The proportion of samples containing immature cartilage tissue taken from the study group was significantly higher than the proportion of those taken from the control group ($p < 0.05$).

Discussion

Worldwide use of electrical devices has resulted in a special interest in the biological effects of the EM fields radiated from these devices. The number of working women have increased rapidly together with the number of VDTs used in the working environment especially during the last half century (1-4). Operation of VDTs by more women during their pregnancies has provoked a discussion about the potential teratogenic effect of the EM fields created by these devices (2, 5, 7).

It is known that the maximum intensity of EM fields radiated by a standard VDT are 50, 2 and 0.3 mG with a frequency of 16 kHz, at 10, 30 and 70 cm away from the screen, respectively (3, 5). If a pregnant VDT operator is assumed to be 30 cm away from the screen, the intensities of the EM fields exposed to her abdomen, her 8 μm oocyte and her 2 mm embryo are calculated to be 1 $\mu\text{V}/\text{m}$, 0.4 $\mu\text{M}/\text{m}$ and 10 $\mu\text{V}/\text{m}$ respectively (1).

Most of the epidemiological studies which assessed the effects of EM fields on human fetuses reported significantly increased risks of spontaneous abortion and growth retardation (1, 2, 5-7). Some of those studies stated that renal, genital, cardiac and skeletal systems and chromosomal abnormalities had been observed more frequently in the fetuses of the VDT operators than in those of the normal population (1, 5, 7). However, neither the increased risks of these abnormalities were observed to be statistically significant, nor was any correlation found between a special type of abnormality and exposure to EM fields.

Increased risks of growth retardation and skeletal system abnormalities were observed in most of the studies which investigated the effects of EM fields on animal fetuses (9, 12, 14)-16). Stuchly et al. found that

exposure to EM fields with an intensity of more than 100 mG significantly increased the risks of variations and minor abnormalities, without affecting the risk of major abnormalities, while Huushonen et al. observed an increased risk of variations, minor and major abnormalities of the skeletal system of rat fetuses (15, 16). Another study, performed by Juutialainen et al., which used chicken embryos reported that exposure to EM fields with a frequency of 16 kHz or more significantly increased the risk of growth retardation and abnormalities of the skeletal system. However, those with lower frequencies did not have any significant effect (9). A comprehensive study, which also used chicken embryos, found that not only the risk of abnormalities of skeletal system and growth retardation were increased significantly by EM fields, but also the increased risk correlated positively with the increased intensities and frequencies of the EM fields (10).

In contrast with these findings Cameron et al. showed that exposure to EM fields resulted in growth retardation but did not cause any structural abnormalities of the rat fetuses, while in another study which used the same animal, neither any abnormality nor any variation in the skeletal system was observed to be increased significantly (11, 17).

In this study, 7 (28.0%) of the 25 litters and 12 (6.3%) of the 189 fetuses exposed to EM fields with an intensity of 10 mG and frequencies of 20 kHz and 50 Hz, were found to have skeletal system abnormalities, including 8 (4.2%) fetuses with a total of 12 major and 4 (2.1%) fetuses with a total of 4 minor abnormalities. One fetus with a major skeletal system abnormality (phocomelia) also had two other major abnormalities (macroglossia and megacolon) of the gastrointestinal system. However, there was no litter or fetus with major or minor abnormalities of any system in the control group. Twelve (48.0%) litters including 41 (21.7%) fetuses in the study group were observed to have a total of 57 skeletal system variations, while only 2 (13.3%) litters including 5 (4.0%) fetuses in the control group had a total of 7 variations of the same system. Both the proportion of the litters and the proportion of the fetuses with skeletal system variations, most of which was believed to be caused by insufficient maturation of cartilage tissues and incomplete ossification of bone tissues, in the study group were found to be significantly higher than those obtained in the control group.

These findings which were comparable to most of those in the literature, suggested that EM fields could alter the normal development of the skeletal system.

Although some studies observed a positive correlation between the intensities and the frequencies of the EM fields and its effects on the skeletal system, no comment on this correlation could be made, as the EM fields used in this study had fixed intensities and frequencies (10).

When the effects of EM fields on bone metabolism were assessed it was found that EM fields increased the entry of calcium ions into the cells of bone tissue and altered the expansion of ossification (19). Because of these effects, EM fields have been used in the treatment of bone fractures of adult humans (20). In contrast, some studies in the literature reported that exposure to EM fields had resulted in retardation of ossification of the bone tissue (7, 8, 16). In this study not only the light microscopic examinations showed that ossification and

segmentation of bone tissues were significantly retarded but also electron microscopic examinations revealed that maturation and differentiation of cartilage tissues were significantly delayed in fetuses exposed to EM fields. These findings suggested that AM fields could also affect the differentiation of soft tissues.

Data obtained in this study suggested that exposure to EM fields during pregnancy could alter the normal development and increase the risk of variations in the skeletal system of rat fetuses. Although it was believed that further studies were needed to confirm this result, more epidemiological studies should also be planned to evaluate the effects of EM fields created by VDTs on human fetuses.

References

- Brent RL, Gordon WE, Bennett WR, Beckman DA. Reproductive and teratologic effects of electromagnetic fields. *Reprod Toxicol* 7: 535-8, 1993.
- Schnorr TM, Grajewski BA, Horning RW. Video display terminals and the risk of spontaneous abortion. *N Engl J Med* 324: 727-33, 1991.
- Kavet R, Tell RA. VDT's: Field levels, epidemiology, and laboratory studies. *Health Physics* 61: 47-57, 1991.
- Nurminen T, Kurppa K. Office employment, work video display terminals and course of pregnancy. *Scand J Work Environ Health* 14: 293-8, 1988.
- Trassner HT, Arnolds CW. Environment and pregnancy. *Medical Therapy in Pregnancy* (Eds. N. Gleicher) Appleton & Lange, East Norfolk 1992, pp: 89-101.
- Brandt LP, Nielsen C. Congenital malformations among children of women working with video display terminals. *Scand J Work Environ Health* 16: 329-33, 1990.
- Chernoff N, Rogers JM, Kavet R. A review of the literature on potential reproductive and developmental toxicity of electric and magnetic fields. *Toxicology* 74: 91-126, 1992.
- Tenforde TS, Kaune WT. Interaction of extremely low frequency electric and magnetic fields with humans. *Health Physics* 53: 585-606, 1987.
- Juutilainen J, Saali K. Development of chick embryos in 1 Hz to 100 kHz magnetic fields. *Radiat Environ Biophys* 25: 135-40, 1986.
- Juutilainen J, Harry M, Saali K, Lathinen T. Effects of 100 Hz magnetic field with various waveforms on the development of chick embryos. *Radiat Environ Biophys* 25: 65-71, 1986.
- Cameron IL, Hunter KE, Winters WD. Retardation of embryogenesis by extremely low frequency 60 Hz electromagnetic fields. *Physiol Chem Phys Med NMR* 17: 135, 1985.
- Zusman I, Yaffe P, Pinus H, Ornoy A. Effects of pulsing electromagnetic fields on the prenatal and postnatal development in mice and rats: In vivo and in vitro studies. *Teratology* 42: 157-70, 1990.
- Delgado JMR, Leal J, Montagudo JL, Gracie G. Embryological changes induced by weak, extremely low frequency electromagnetic fields. *J Anat* 134: 533-51, 1982.
- Martin AH. Magnetic fields and time dependent effects on development. *Bioelectromagnetics* 9: 393-6, 1988.
- Stuchly MA, Ruddick J, Villeneuve D. Teratological assessment of exposure to time-varying magnetic field. *Teratology* 38: 461-6, 1988.
- Huuskonen H, Juutilainen J, Komulainen H. Effects of low-frequency fields on fetal development in rats. *Bioelectromagnetics* 14: 205-13, 1993.
- Rommereim DN, Kaune WT, Buschborn RL, Phillips RD, Sikov MR. Reproduction and development in rats chronologically exposed to 60-Hz electric fields. *Bioelectromagnetics* 8: 243-58, 1987.
- Bareggi R, Grill V, Zwyer M, Narducci P, Frobosca A. A quantitative study on the spatial and temporal ossification patterns of vertebral centra and neural arches and their relationship to the fetal age. *Ann Anat* 176: 311-7, 1994.
- Adey WR. Tissue interactions with nonionizing electromagnetic fields. *Physiol Rev* 61: 435-510, 1981.
- Andrew C, Bassett L. The development and application of pulsed electromagnetic fields (PEMF's) for ununited fractures and arthrodeses. *Orthop Clin North Am* 25: 61-7, 1984.