

Using Superconducting Qubit Circuits to Engineer Exotic Lattice Systems

Dimitris I. Tsomokos¹, Sahel Ashhab^{2,3}, Franco Nori^{2,3}

¹*Department of Mathematics, Royal Holloway, University of London, Egham TW20 0EX, UK*

²*Advanced Science Institute, The Institute of Physical and Chemical Research (RIKEN), Wako-shi, Saitama 351-0198, Japan*

³*Physics Department, University of Michigan, Ann Arbor, Michigan 48109-1040, USA*

(Dated: September 16, 2010)

We propose an architecture based on superconducting qubits and resonators for the implementation of a variety of exotic lattice systems, such as spin and Hubbard models in higher or fractal dimensions and higher-genus topologies. Spin systems are realized naturally using qubits, while superconducting resonators can be used for the realization of Bose-Hubbard models. Fundamental requirements for these designs, such as controllable interactions between arbitrary qubit pairs, have recently been implemented in the laboratory, rendering our proposals feasible with current technology.

PACS numbers: 64.60.De, 05.50.+q, 85.25.Cp, 42.50.Dv

I. INTRODUCTION

The idea of quantum simulation has led to a large number of theoretical proposals and some remarkable experimental results over the past decade [1]. For example, the transition between a superfluid and a Mott insulator, which is a classic condensed-matter-physics paradigm, has been investigated in a controlled fashion using a gas of ultracold atoms [2]. Based on the success of such experiments, there have been intense efforts to devise methods for the simulation of various physical problems whose theoretical analysis is challenging. One area that has been studied substantially in the theoretical literature, with a number of fundamental questions still unanswered, is that of lattice systems in arbitrary dimensions and topologies. Implementing such systems using naturally occurring systems in two or three dimensions is challenging because the required connectivity is incompatible with the geometry of the *physical* space in which the spins or lattice sites reside. Here we propose the implementation of such exotic systems using electronic nanocircuits based on superconducting qubits (SQs) and superconducting resonators [3].

The basic elements required for the implementation of our proposals have all been demonstrated experimentally. In particular, in a recent experiment [4], Harris *et al.* fabricated a SQ circuit with $N > 100$ qubits and demonstrated fully controllable interactions in blocks of 8 qubits, i.e. essentially *all pairs* of qubits were coupled to each other with individually controllable coupling strengths. This ability to design at will tunable couplings between any pair of qubits is a crucial ingredient in our proposal for experimentally engineering exotic quantum architectures, which are hard to study otherwise. We investigate a range of systems that can be implemented using such SQ circuits with fully controllable interactions. The experiments that we propose should be realizable in the near future, particularly those related to the thermodynamic properties of classical spin systems, where many-qubit coherence is not required.

We start by reviewing the present-day technology of

superconducting qubits, resonators and tunable couplers. We then go through our list of proposals. In particular, we examine complex quantum systems in *higher* and *nonconventional* dimensions, such as spin lattices in noninteger (fractal) dimensions [5–7], and we consider the embedding of lattice systems on *exotic topologies*, such as the Klein bottle and Möbius strip [8–10]. Both types of systems (i.e. those involving nonconventional dimensions or topologies) could advance our understanding of phase transitions [11–13] and lead to practical applications. For example, it is known that dimensionality plays an important role in phase transitions [11], and the ability to engineer any desired dimension would provide a valuable experimental knob in their study. Furthermore, spin lattices in nontrivial topologies and in higher dimensions have been shown to be better suited for implementing passive quantum-information-protecting schemes than conventional systems [14]. Near the end of the paper, we discuss the implications of the *in-situ* tunability of the parameters and the possibility of performing novel *topology quench* experiments.

II. PHYSICAL IMPLEMENTATION

Although various types of SQs could be used to implement the architectures that we propose here, we shall focus on flux qubits, since these were used in the experiments of Ref. [4]. The flux qubit is a superconducting loop interrupted by a number of Josephson junctions, typically one to four [3], as illustrated in Fig. 1(a). When a magnetic flux close to half a flux quantum is applied through the loop, two quantum states (one with clockwise and the other with counterclockwise circulating current) are almost degenerate and form the qubit basis. These states are usually denoted by $|\uparrow\rangle$ and $|\downarrow\rangle$, and the qubit can be thought of as a spin-1/2 particle. The single-qubit Hamiltonian in the language of Pauli matrices $\hat{\sigma}^{x,y,z}$ is

$$\hat{H}_q = \frac{\Delta}{2}\hat{\sigma}^x + \frac{\epsilon}{2}\hat{\sigma}^z, \quad (1)$$

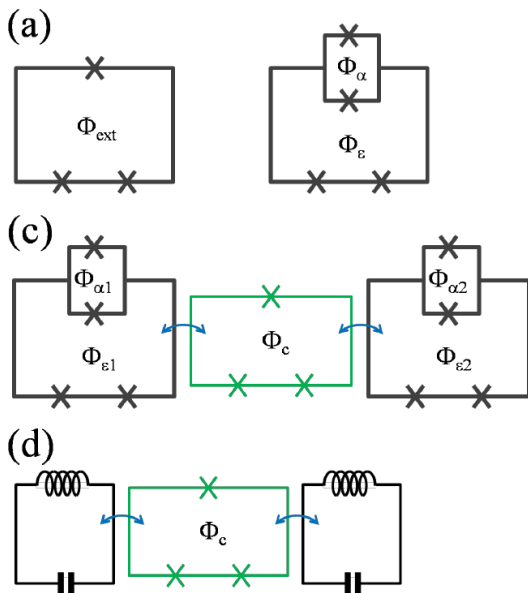

FIG. 1: (Color online) Schematic diagrams of (a) a simple three-junction flux qubit, (b) a flux qubit with a tunable gap, (c) two flux qubits interacting through a tunable coupler, and (d) two resonators interacting through a tunable coupler. In (a) the external magnetic flux Φ_{ext} threading the superconducting loop controls the parameter ϵ in the single-qubit Hamiltonian (Eq. 1). In (b) the magnetic flux Φ_{ϵ} controls the parameter ϵ in the Hamiltonian, while Φ_{α} controls the parameter Δ . In (c) two flux qubits are coupled inductively to a common coupler, resulting in an effective coupling between the two qubits. The effective coupling strength J can be tuned through the magnetic flux Φ_C . In (d) two LC circuits, i.e. resonators, are effectively coupled to each other through a tunable coupler.

where Δ is the minimum gap at the half-flux bias point and ϵ is the deviation from this point. It is worth noting here that ϵ is an easily tunable parameter and that it has recently become possible to also tune Δ using the externally applied magnetic fields [15], as shown in Fig. 1(b).

If two qubits are placed next to each other, the magnetic-dipole interaction gives rise to a two-qubit coupling term of the form

$$\hat{H}_{\text{int,q-q}} = J\hat{\sigma}_1^z\hat{\sigma}_2^z, \quad (2)$$

where J is the coupling strength and the subscripts indicate the different qubits. For two directly coupled qubits, the coupling strength J is fixed by geometry and material properties. One could avoid this limitation and obtain an effectively tunable coupling strength by employing a coupler, an additional circuit element that mediates coupling between the two qubits [16]. A schematic diagram of this technique is shown in Fig. 1(c). By tuning the bias parameters (e.g. the magnetic flux through the coupler's loop), one can effectively tune the inter-qubit coupling strength J . An additional advantage of using couplers is the flexibility allowed in their design, which leads to the ability to couple qubits that are separated by large

distances and to produce coupling terms in any desired pairing of the qubits [4]. With the above architecture, one obtains the many-qubit Hamiltonian

$$\hat{H}_1 = \sum_i (\Delta_i \hat{\sigma}_i^x + \epsilon_i \hat{\sigma}_i^z) / 2 + \sum_{i,j} J_{i,j} \hat{\sigma}_i^z \hat{\sigma}_j^z, \quad (3)$$

with at least the parameters ϵ_i and $J_{i,j}$ being *in-situ* tunable. Further details concerning the circuit can be found in Ref. [4].

While qubits are suited for the implementation of spin-lattice Hamiltonians, Bose-Hubbard Hamiltonians require harmonic-oscillator-like circuit elements, i.e. resonators. These can be implemented either as lumped-element LC circuits, as illustrated in Fig. 1(d), or as coplanar-waveguide resonators [3]. In both cases, the resonator behaves as a linear oscillator with the Hamiltonian

$$\hat{H}_{\text{osc}} = \hbar\omega \left(\hat{a}^\dagger \hat{a} + \frac{1}{2} \right), \quad (4)$$

where ω is the oscillator frequency and \hat{a}^\dagger and \hat{a} are the oscillator's creation and annihilation operators, respectively. Several experiments have demonstrated coherent coupling between resonators and qubits [3]. With the technology that has been developed in that context, there should be no difficulty in coupling resonators to each other using couplers, thus leading to tunable coupling with any desired pairing of the resonators. The interaction Hamiltonian is then given by

$$\hat{H}_{\text{int,q-osc}} = J \left(\hat{a}_i^\dagger \hat{a}_j + \hat{a}_j^\dagger \hat{a}_i \right), \quad (5)$$

where the subscripts indicate the different resonators. In writing this form for the Hamiltonian, we have assumed that $J \ll \hbar\omega/n$ (with n being the typical number of excitations in each resonator) such that the rotating-wave approximation is valid. The resonators can now be seen as sites in a Hubbard-like model, and the number of excitations in any given resonator represents the number of (bosonic) particles occupying that site. One thus obtains the non-interacting Bose-Hubbard Hamiltonian

$$\hat{H}_2 = \sum_i \hbar\omega_i (\hat{a}_i^\dagger \hat{a}_i + 1/2) + \sum_{i,j} J_{i,j} (\hat{a}_i^\dagger \hat{a}_j + \hat{a}_j^\dagger \hat{a}_i), \quad (6)$$

with the parameters $J_{i,j}$ being *in-situ* tunable. The resonator frequencies ω_i generally exhibit small deviations from the values specified when designing the circuit, and recent experiments have demonstrated resonators with tunable values of ω [17].

III. NONCONVENTIONAL DIMENSIONS

On the theoretical side, spin lattice systems in higher dimensions ($d \geq 3$) have been studied extensively in the past [11]. Interest in these higher-dimensional systems stems from the important role that dimensionality plays in the physics of phase transitions and critical phenomena, as well as in determining the magnetic

and thermodynamic properties of materials. Over the years, a number of different theoretical methods have been used in studying higher-dimensional systems, including renormalization-group and Monte-Carlo methods. However, the validity of these methods generally cannot be established rigorously [18]. Therefore, experimental investigation of higher-dimensional systems is highly desirable. The experimental realization of such systems is hindered, however, by the difficulties associated with coupling spatially separated elements, such as distinct two-level systems.

With SQ networks it should be possible to overcome the difficulty of arbitrary connectivity. The Ising model in $d = 1, 2, 3, \dots$ dimensions can be implemented using the connections illustrated in Fig. 2. In this context one might worry whether the crossing of some of the lines in Fig. 2 would be a problem. However, this is not the case, since such lines can be fabricated in different layers, similarly to what was done in Ref. [4]. Naturally there would be physical limits on the number of layers in a realistic system, and one might worry that for larger numbers of qubits a larger number of layers will be required. However, the number of layers does not depend on the system size, but only on the engineered effective dimension: in principle no overlapping connections are needed for $d = 2$, only two layers of couplers are needed for $d = 3$, and so on.

Similarly to higher-dimensional systems, spin systems with noninteger dimensions have also received much theoretical interest over the past few decades but have not been implemented experimentally [5–7]. One example of interesting theoretical results in this context is that the Ising model can exhibit spontaneous magnetization at finite temperatures on spin lattices with $d < 2$ [6]; another is the prediction that certain spin models change critical behavior from second to first order at specific noninteger dimensions [7].

One way to obtain noninteger dimensions, without losing local structure, is to use fractal geometries. Indeed, the proposed SQ architectures can be used to implement the Ising model on a well-studied fractal that can be used to probe noninteger dimensions between $d = 1$ and $d = 2$, namely, the *Sierpinski carpet* [5]. The relevant construction is illustrated and explained in Fig. 3. Note that a two-dimensional lattice of qubits without any qubits missing can be used to generate any desired dimension between 1 and 2. This is achieved by decoupling any unneeded qubits from the rest of the lattice using the tunable couplers, effectively removing these qubits from the system and creating holes in their place. Alternatively, the Sierpinski carpet can be generated by engineering the connections between the different qubits on the chip, even if the qubits are not arranged in a two-dimensional lattice (as explained in Fig. 2).

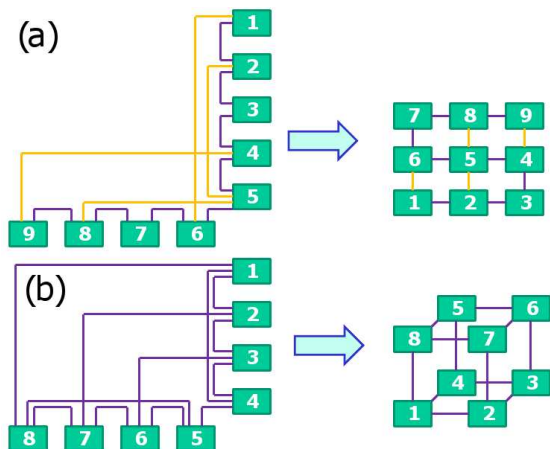

FIG. 2: (Color online) Engineering the effective dimensionality of a lattice system by changing the connections between qubits: (a) Nine qubits can be connected so as to form a linear chain [purple (black) connections] or a 3×3 square lattice [purple (black) and orange (gray) connections]. (b) Eight qubits can be connected into a three-dimensional cube.

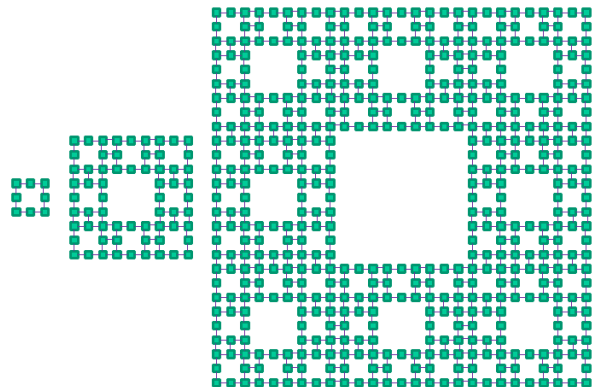

FIG. 3: (Color online) First few generations of a Sierpinski carpet with dimension $\log[8]/\log[3] \approx 1.9$: one starts from a square of 8 qubits, a 3×3 lattice with the middle qubit removed; then each site is replaced by the original, first-generation square; and so on. Any dimension between 1 and 2 can be obtained by adjusting the total size and missing fraction in the first-generation square: if the length of the square is n qubits and the length of the missing core is l qubits, the effective dimension is $\log[n^2 - l^2]/\log[n]$. Starting from a three-dimensional cube, one can obtain any dimension between 2 and 3, and so on.

IV. EXOTIC TOPOLOGIES

A substantial amount of theoretical work has been devoted to the critical behavior of spin lattices with non-trivial topology [8]. Experimental realizations have been possible with thin film materials [9, 10], but with limited controllability of subsystems. An open question in this area is whether there is any general principle connecting the properties of a many-body system with the curvature or the topology of the surface on which the system

resides. It would therefore be desirable to have small-scale lattices with local addressability, whose underlying topology is also controllable.

With the designs proposed here, this experimental goal becomes more feasible. For example, it would be possible to engineer a spin system whose topology is either a *torus* or a *Klein bottle*. These two lattice topologies can be engineered as follows: we start from, say, the 3×3 lattice shown in Fig. 2(a). In addition to the connections shown, we impose periodic boundary conditions along the vertical direction, i.e. we connect qubits (1-7), (2-8) and (3-9). The type of connections made along the horizontal direction then differentiates between a torus and a Klein bottle. For the torus we connect qubits (1-3), (4-6) and (7-9); while for the Klein bottle we connect (1-9), (4-6) and (3-7).

The simplest model one could study on these structures is the Ising model, where nearest neighbors $\langle i, j \rangle$ interact via a $\hat{\sigma}_i^z \hat{\sigma}_j^z$ coupling term. One could also apply an effective transverse field, i.e. a $\hat{\sigma}_i^x$ term in the Hamiltonian, of strength λ , on every qubit and obtain signatures of a *quantum* phase transition [12] as the parameter λ is varied. One of the most telling signs of the system passing through a ‘critical’ value λ_c , is that the *entanglement* properties of the ground state wavefunction change quite drastically [13]. Even small systems of, say, $N = 4, 9, 16$ qubits, will display cusps of increasing sharpness in some entanglement measure, such as the concurrence between two neighboring qubits. Such entanglement properties can be measured relatively easily in the proposed architecture. Since the coupling strengths are all tunable, the qubits can all be decoupled from one another. Then, by selectively turning on and off certain coupling strengths and performing the required quantum gates, the necessary multi-qubit observables can be measured, e.g., following quantum state tomography or entanglement witness measurement protocols.

V. BOSE-HUBBARD MODELS

The architectures described above for spin lattice systems in nonconventional dimensions and topologies can also be implemented using resonators, such that the result is a Bose-Hubbard system. In such systems, one can study the transport properties of the excitations, which play the role of bosonic particles. In particular, one can investigate the superfluid-Mott-insulator phase transition and the Anderson-localization phase transition.

In order to investigate the superfluid-Mott-insulator phase transition, one needs inter-particle interactions. Such interactions can be engineered by coupling each resonator to a qubit, similarly to the proposals of Ref. [19]. In order to investigate the Anderson-localization phase transition, one needs disorder in the single-site energies or nearest-neighbor coupling strengths (i.e. hopping matrix elements). Engineering such disorder is straightforward with superconducting circuits, where each site energy and each coupling strength is individually tunable. A recent theoretical work also proposed the possibility of engineered time-reversal symmetry breaking in a system of coupled superconducting resonators [20]. This idea can also be implemented in the systems of arbitrary dimension or topology proposed in our work.

An important quantity in the study of many-body physics is the two-point correlation function of the form $\langle a_i^\dagger a_j \rangle$. The tunability of the coupling strengths in SQ systems enables one to measure this quantity relatively straightforwardly. One starts by turning all the couplings off. By measuring the number of excitations in each resonator, and repeating the experiment a large number of times, one obtains $\langle a_i^\dagger a_i \rangle$. If then one couples only resonators i and j with coupling strength J as described by \hat{H}_2 , the number of excitations as a function of time is given by

$$\langle a_i^\dagger(t) a_i(t) \rangle = \langle a_i^\dagger(0) a_i(0) \rangle \cos^2 \left(\frac{Jt}{\hbar} \right) + \langle a_j^\dagger(0) a_j(0) \rangle \sin^2 \left(\frac{Jt}{\hbar} \right) - \frac{i}{2} \langle a_i^\dagger(0) a_j(0) - a_j^\dagger(0) a_i(0) \rangle \sin \left(\frac{2Jt}{\hbar} \right). \quad (7)$$

One can therefore use the resulting oscillations in order to extract the imaginary part of $\langle a_i^\dagger(0) a_j(0) \rangle$. Repeating the same procedure with a $\pi/2$ phase shift applied to one of the resonators, allows the extraction of the real part of $\langle a_i^\dagger(0) a_j(0) \rangle$.

VI. QUENCH DYNAMICS AND TOPOLOGY-QUENCH EXPERIMENTS

The *in-situ* tunability of the parameters in SQ circuits enables one to perform quench-related experiments,

where the parameters are changed from some initial configuration to a different one. What starts out being the ground state or thermal-equilibrium state then becomes an excited state that tends to relax to the new ground state or thermal-equilibrium state. How this relaxation takes place, and whether it is possible at all under the constraints imposed by conservation laws has been a subject of extensive studies in the past [13, 21]. The quintessential example of such quench problems is the Kibble-Zurek mechanism [22], which describes defect formation in systems that are quenched from one thermodynamic phase into another and is proposed as the mech-

anism for pattern formation, such as galaxy creation, in the early universe. Using the SQ architecture discussed here, one can quench the parameters across any of the phase transitions mentioned above and analyze the resulting dynamics of the system.

We also propose the idea of implementing *topology-quench* experiments, in which a system is initially embedded in one topology and, subsequently, its internal interactions are changed in order to obtain a different topology. The idea can be explained using the 3×3 lattice of Fig. 2(b), which can be turned into a torus or a Klein bottle, as explained above. The two different topologies differ by two of the connections implementing the boundary conditions: (1-3) and (7-9) versus (1-9) and (3-7). A topology quench can be performed by switching off the torus-generating connections and then switching on the Klein bottle-generating connections. It is known that the partition functions of the Ising model in these two different topologies are not the same [8], and we would therefore expect to see signatures of the different orders as we change from one topology to the other. These may be manifested by the magnetization and thermal entanglement properties [13]. In this case, it is the actual topology of the underlying lattice structure that changes as one set of interactions is turned off and another is turned on. The reordering of the quantum state via the Kibble-Zurek mechanism will consequently have to follow this change of topology of the lattice.

VII. TYPICAL EXPERIMENTAL PARAMETERS

Superconducting flux qubits typically have minimum gaps [i.e. the parameter Δ in Eq. (1)] in the range 3-7 GHz [3]. Recently, new qubit designs have made this parameter *in-situ* tunable, with a minimum value of essentially zero [15]. The parameter Δ can therefore be tuned to any value between 0 and 7 GHz. By changing the externally applied flux in the large qubit loop, the parameter ϵ can be tuned to any value between 0 and values higher than 20 GHz.

The coupling strength between a qubit and a coupler can be designed through the kinetic inductance arising from shared superconducting segments or Josephson junctions. Coupling strengths close to 1 GHz have been achieved [23], and with straightforward parameter changes it should be possible to reach values of about 2 GHz. Couplers typically have minimum gaps Δ in the range 10-20 GHz. These parameters can result in a maximum inter-qubit coupling strength on the order of a few hundred MHz [16] (Note that, by the design of the circuit under consideration, the effective inter-qubit coupling strength is tunable). It is therefore possible to explore parameter combinations extending from the regime where the single-spin energies (including both σ_x and σ_z components) are larger than the interaction energy to the regime where the opposite is true. This is the region

where phase transitions are expected to occur, suggesting that the experimental investigation of these phase transitions and related critical phenomena in superconducting qubit circuits is feasible.

Superconducting resonators with frequencies in the few-Gigahertz range, which is the natural range to use in qubit circuits, can be designed and fabricated with high controllability. In qubit-resonator circuits, coupling strengths in the range of 10-100 MHz are common, and recent experiments have achieved coupling strengths close to 1 GHz [24]. Since superconducting couplers have similar structure to qubits, similar resonator-coupler coupling strengths can be expected. The above numbers indicate that inter-resonator coupling strengths (i.e. hopping coefficients) and on-site inter-particle interaction coefficients on the order of a few hundred MHz should be achievable. Since the competition between inter-site hopping and on-site interactions governs the Superfluid-Mott-Insulator transition, one should be able to access the Superfluid-Mott-Insulator transition in the proposed architecture. Disorder of magnitudes smaller than or larger than hundreds of MHz can also be achieved, implying that the Anderson-localization transition can also be investigated.

Typical decay rates for both qubits and resonators are on the order of 1 microsecond in superconducting circuits. It has been a challenge to experimentally fabricate multiple qubits on one chip where all of the qubits have coherence times at that scale. However, it is expected that in the future long coherence in multi-qubit circuits will be possible. When that goal is achieved, it will mean that the overall coherence timescale will be long compared to typical parameters in the Hamiltonian, which are on the order of tens of nanoseconds or shorter.

VIII. CONCLUSIONS AND OUTLOOK

Facilitated by high levels of controllability and steadily improving coherence properties, superconducting qubits and resonators are finding various potential applications in quantum information processing and condensed-matter physics. For example, there have recently been a number of proposals for using them as quantum simulators [1]. In this context, the single qubit/resonator controllability and readout is a key advantage of superconducting qubits compared to microscopic simulators, such as natural atoms or ions.

In this work, we have added to the list of feasible potential applications of superconducting circuits the engineering of lattice systems in arbitrary dimension and topology. In particular, we have proposed to engineer spin lattices in integer dimensions $d \geq 3$, fractal dimensions and nonconventional topologies. We have also discussed how Bose-Hubbard lattice systems in similar exotic dimensions and topologies can be implemented using superconducting resonators. An advantage of SQ systems in this context, which is particularly exploited in our propos-

als, is the high level of connectivity [25] between superconducting qubits, resonators and hybrid qubit-resonator systems. Furthermore, the *in-situ* tunability of the parameters allows for the design of quench, or even *topology quench*, experiments: in such experiments the internal reordering of the system could be observed as the connections between lattice sites are changed. In this case, the very topology of the underlying lattice could be quenched, thereby opening the way to a rather different type of quantum quench experiments.

We should emphasize that our proposal for investigating signatures of phase transitions in the Ising model does *not* require multi-qubit quantum coherence. Additionally, fluctuations in the parameters can be tolerated for purposes of analyzing the presence or absence of phase

transitions. Such experiments should therefore be easier to realize in the near future. Experiments combining both scalability and long multi-qubit coherence times are expected in the coming few years, at which point the investigation of quantum phase transitions and critical phenomena using superconducting lattice systems can also be realized.

We would like to thank M. Blencowe and J. R. Johansson for useful discussions. This work was supported in part by the EPSRC-GB grant No. EP/G045771/1, DARPA, LPS, NSA, ARO, NSF grant No. 0726909, Grant-in-Aid for Scientific Research (S), MEXT Kakenhi on Quantum Cybernetics, and Funding Program for Innovative R&D on S&T (FIRST).

-
- [1] I. Buluta and F. Nori, *Science* **326**, 108 (2009).
- [2] M. Greiner, O. Mandel, T. Esslinger, T. W. Hänsch, and I. Bloch, *Nature* **415**, 39 (2002).
- [3] J. Q. You and F. Nori, *Phys. Today* **58** (11), 42 (2005); R. J. Schoelkopf and S. M. Girvin, *Nature*, **451**, 664 (2008); J. Clarke and F. K. Wilhelm, *Nature* **453**, 1031 (2008).
- [4] R. Harris *et al.*, arXiv:1004.1628v1; M. W. Johnson *et al.*, *Supercond. Sci. Technol.* **23**, 065004 (2010).
- [5] T. Nakayama and K. Yakubo, *Fractal Concepts in Condensed Matter Physics* (Springer, 2003).
- [6] Y. Gefen, B. B. Mandelbrot, and A. Aharony, *Phys. Rev. Lett.* **45**, 855 (1980); Y. Gefen, A. Aharony, and B. B. Mandelbrot, *J. Phys. A: Math. Gen.* **17**, 1277 (1984); G. Banhot, H. Neuberger, and J. A. Shapiro, *Phys. Rev. Lett.* **53**, 2277 (1984); M. A. Novotny, *Phys. Rev. Lett.* **70**, 109 (1993); G. P. Zheng and M. Li, *Phys. Rev. E* **62**, 6253 (2000); G. Pruessner, D. Loison, and K. D. Schotte, *Phys. Rev. B* **64**, 134414 (2001); M. Shinoda, *J. Appl. Probab.* **39**, 1 (2002); A. Vezzani, *J. Phys. A: Math. Gen.* **36**, 1593 (2003).
- [7] M. Tissier, B. Delamotte, and D. Mouhanna, *Phys. Rev. Lett.* **84**, 5208 (2000); A. Peles and B. W. Southern, *Phys. Rev. B* **69**, 081403(R) (2004).
- [8] S. Yamaguchi, *Prog. Theor. Phys.* **97**, 703 (1997); W. T. Lu and F. Y. Wu, *Phys. Lett. A* **259**, 108 (1999); *Phys. Lett. A* **293**, 235 (2002); *Phys. Rev. E* **63**, 026107 (2001); C. H. Otto Chui and P. A. Pearce, *J. Stat. Phys.* **107**, 1167 (2002); N. Zhao, H. Dong, S. Yang, and C. P. Sun, *Phys. Rev. B* **79**, 125440 (2009).
- [9] S. Kawata, H.-B. Sun, T. Tanaka, and K. Takeda, *Nature* **412**, 697 (2001); V. F. Puentes, K. M. Krishnan, and A. P. Alivisatos, *Science* **291**, 2115 (2001); S. Tanda, T. Tsuneta, Y. Okajima, K. Inagaki, K. Yamaya, and N. Hatakenaka, *Nature* **417**, 397 (2002); H. Yoshikawa, K. Hayashida, Y. Kozuka, A. Horiguchi, and K. Awaga, *Appl. Phys. Lett.* **85** 5287 (2004).
- [10] A. M. Turner, V. Vitelli, and D. R. Nelson, *Rev. Mod. Phys.* **82**, 1301 (2010).
- [11] F. Y. Wu, *Exactly Solved Models: A Journey In Statistical Mechanics* (World Scientific, 2009).
- [12] S. Sachdev, *Quantum Phase Transitions* (Cambridge University Press, 2000).
- [13] L. Amico, R. Fazio, A. Osterloh, and V. Vedral, *Rev. Mod. Phys.* **80**, 517 (2008).
- [14] E. Dennis, A. Kitaev, A. Landahl, and J. Preskill, *J. Math. Phys.* **43**, 4452 (2002); D. Bacon, *Phys. Rev. A* **73**, 012340 (2006).
- [15] F. G. Paauw, A. Fedorov, C. J. P. M. Harmans, and J. E. Mooij, *Phys. Rev. Lett.* **102**, 090501 (2009); X. Zhu, A. Kemp, S. Saito, and K. Semba, arXiv:1008.4016.
- [16] D. V. Averin and C. Bruder, *Phys. Rev. Lett.* **91**, 057003 (2003); B. L. T. Plourde, J. Zhang, K. B. Whaley, F. K. Wilhelm, T. L. Robertson, T. Hime, S. Linzen, P. A. Reichardt, C.-E. Wu, and J. Clarke, *Phys. Rev. B* **70**, 140501(R) (2004); M. Wallquist, J. Lantz, V. S. Shumeiko, and G. Wendin, *New J. Phys.* **7**, 178 (2005); A. Maassen van den Brink, A. J. Berkley, and M. Yalowsky, *New J. Phys.* **7**, 230 (2005); S. Ashhab, A. O. Niskanen, K. Harrabi, Y. Nakamura, T. Picot, P. C. de Groot, C. J. P. M. Harmans, J. E. Mooij, and F. Nori, *Phys. Rev. B* **77**, 014510 (2008).
- [17] M. Sandberg, C. M. Wilson, F. Persson, G. Johansson, V. Shumeiko, T. Duty, and P. Delsing, *App. Phys. Lett.* **92**, 203501 (2008).
- [18] See, e.g., P. H. Lundow and K. Markström, *Phys. Rev. E* **80**, 031104 (2009).
- [19] M. J. Hartmann, F. G. S. L. Brandao, and M. B. Plenio, *Nat. Phys.* **2**, 849 (2006); A. D. Greentree, C. Tahan, J. H. Cole, and L. C. L. Hollenberg, *Nature Phys.* **2**, 856 (2006).
- [20] J. Koch, A. A. Houck, K. Le Hur, and S. M. Girvin, arXiv:1006.0762.
- [21] J. Dziarmaga, arXiv:0912.4034.
- [22] T. W. B. Kibble, *J. Phys. A* **9**, 1387 (1976); W. H. Zurek, *Nature* **317**, 505 (1985); *Phys. Rep.* **276**, 177 (1996).
- [23] A. O. Niskanen, K. Harrabi, F. Yoshihara, Y. Nakamura, S. Lloyd, and J. S. Tsai, *Science* **316**, 723 (2007); K. Harrabi, F. Yoshihara, A. O. Niskanen, Y. Nakamura, and J. S. Tsai, *Phys. Rev. B* **79**, 020507 (2009); see also P. C. de Groot, J. Lisenfeld, R. N. Schouten, S. Ashhab, A. Lupascu, C. J. P. M. Harmans, and J. E. Mooij, arXiv:1008.1294.
- [24] P. Forn-Diaz, J. Lisenfeld, D. Marcos, J. J. Garcia-Ripoll, E. Solano, C. J. P. M. Harmans, and J. E. Mooij, arXiv:1005.1559.
- [25] The high connectivity of superconducting qubits in

circuit-QED setups has recently been exploited to propose simulations of highly-connected spin lattice systems; D. I. Tsomokos, S. Ashhab, and F. Nori, *New J. Phys.*

10, 113020 (2008); J. Larson, *Europhys. Lett.* **90**, 54001 (2010).