

## Instruments of RT-2 Experiment onboard CORONAS-PHOTON and their test and evaluation V: Onboard software, Data Structure, Telemetry and Telecommand

S. Sreekumar · P. Vinod · Essy Samuel · J. P. Malkar · A. R. Rao · M. K. Hingar · V. P. Madhav · D. Debnath · T. B. Kotoch · Anuj Nandi · S. Shaheda Begum · Sandip K. Chakrabarti

Received: date / Accepted: date

**Abstract** The onboard software and data communication in the RT-2 Experiment onboard the Coronas-Photon satellite is organized in a hierarchical way to effectively handle and communicate asynchronous data generated by the X-ray detectors. A flexible data handling system is organized in the X-ray detector packages themselves and the processing electronic device, namely RT-2/E, has the necessary intelligence to communicate with the 3 scientific payloads by issuing commands and receiving data. It has direct interfacing with the Satellite systems and issues commands to the detectors and processes the detector data before sending to the satellite systems. The onboard software is configured with several novel features like a) device independent communication

This work was made possible in part from a grant from Indian Space Research Organization (ISRO). The whole-hearted support from G. Madhavan Nair, Ex-Chairman, ISRO, who initiated the RT-2 project, is gratefully acknowledged.

S. Sreekumar, P. Vinod, Essy Samuel  
Vikram Sarabhai Space Centre, VRC, Thiruvananthapuram 695022  
E-mail: sreekumar\_s@vssc.gov.in

J. P. Malkar, A. R. Rao, M. K. Hingar, V. P. Madhav  
Tata Institute of Fundamental Research, Homi Bhabha Road, Colaba, Mumbai 400005

D. Debnath, T. B. Kotoch, A. Nandi<sup>+</sup>  
Indian Centre for Space Physics, 43 Chalantika, Garia Station Rd., Kolkata 700084  
Tel.: +91-33-24366003  
Fax: +91-33-24622153 Ext. 28  
E-mail: dipak@csp.res.in; tilak@csp.res.in; anuj@csp.res.in (+: Posted at ICSP by Space Science Division, ISRO Head Quarters, Bangalore)

S. Shaheda Begum  
Radio Astronomy Centre, NCRA-TIFR, Ooty 643001

Sandip K. Chakrabarti  
S.N. Bose National Centre for Basic Sciences, JD Block, Salt Lake, Kolkata 700097  
(Also at Indian Centre for Space Physics, 43 Chalantika, Garia Station Rd., Kolkata 700084)  
Tel.: +91-33-23355706  
Fax.: +91-33-23353477  
E-mail: chakraba@bose.res.in

scheme, b) loss-less data compression and c) Digital Signal Processor. Functionality of the onboard software along with the data structure, command structure, complex processing scheme etc. are discussed in this paper.

**Keywords** Satellites communication · X- and gamma-ray telescopes and instrumentation · Data acquisition · Telemetry

**PACS** 84.40.Ua · 95.55.Ka · 07.05.Hd · 84.40.Xb

## 1 Introduction

RT-2 Experiment onboard the Coronas-Photon satellite (Kotov et. al. 2008) consists of 3 scientific and 1 processing electronic payloads (Nandi et al. 2009a). The processing electronic device, namely, RT-2/E communicates with the scientific payloads and the ground stations through SSRNI (System of Collection and Registration of Scientific Informations or SCRSI in English) and the Control and Communication unit (BUS-FM) of the satellite. The three scientific payloads are RT-2/S & RT-2/G (both Phoswich scintillating detectors of NaI(Tl)/CsI(Na) crystals) and RT-2/CZT (solid-state imaging detector). In Debnath et al. (2009), Kotoch et al. (2009), Nandi et al. (2009), we described the technical aspects of three scientific payloads, their functionality and different imaging techniques that are designed and implemented in the RT-2/CZT payload. In Sarkar et al. (2009), we mainly discussed the effect of the cosmic diffuse high energy X-ray background on all the three detectors through Monte-Carlo simulations as implemented in GEANT-4 toolkit.

The RT-2 Experiment covers the energy range of 15 to 150 keV extendable up to 1 MeV. All three payloads have different fields of view ranging from  $4^\circ \times 4^\circ$  (RT-2/S),  $6^\circ \times 6^\circ$  (RT-2/G) and  $6' - 6^\circ$  (RT-2/CZT). In order to view the sky (Sun) in the low energy  $\gamma$ -ray range, all the three detector systems are placed outside the hermetically sealed module of the satellite. The three detectors are mounted with instrument axis parallel to the Sun pointing axis of the satellite. On the other hand, RT-2/E along with other processing systems of the satellite are placed inside the hermetically sealed chamber of the satellite.

In the present paper, we will concentrate on the onboard software and the overall functionality of RT-2/E. The schematic diagram of RT-2 system is shown in Figure 1.

## 2 Description of the processing electronics (RT-2/E)

RT-2/E is the main processing electronic device of the RT-2 Experiment and it acts as an interface between the detector electronics and the satellite system. The unit decodes the telecommand appropriately and transmits the detector data to the ground through the satellite telemetry, which also involves the functions of compressing and making packets of the data from the detectors. The control logic system of the device is FPGA (Field Programmable Gate Array), which carries all the logical operations in the RT-2/E. A Digital Signal Processor ADSP2101 is used in the system for data processing. The RT-2/E electronics also consists of input and output buffers for detectors, satellite interface, electronics for power interface, memory interface. The schematic block diagram of RT-2/E device is shown in Figure 2. A continuous power supply to the RT-2 system is provided by the Control and communication unit (BUS-FM) of the satellite.

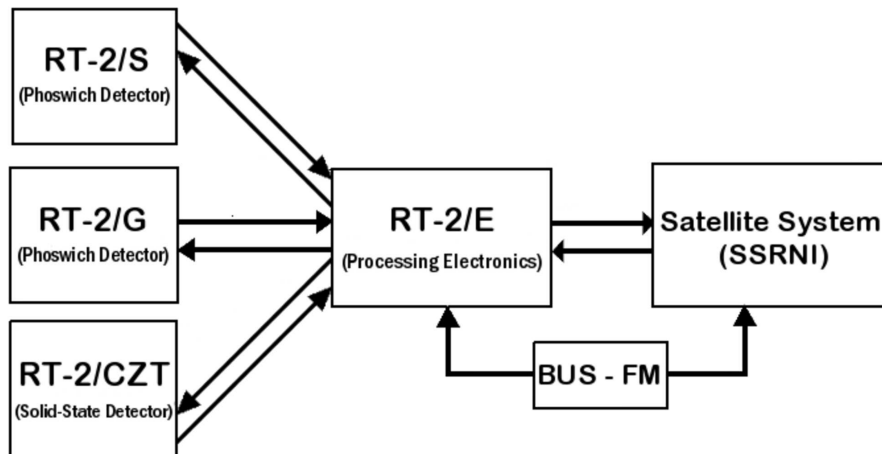

Fig. 1 Schematic diagram of RT-2 system.

Power supply is provided by a DC current source with the Voltage of  $27_{-3}^{+7}$  Volt without a midpoint. The maximum power provided for the RT-2 system is 32 Watt.

RT-2/E weighs 8.56 kg and the power consumption of the device is 3.78 Watt,  $\leq 10$  kg and  $\leq 5$  Watt, respectively, as per design requirement. RT-2/E is operable in the temperature range of  $-10^{\circ}\text{C}$  to  $+40^{\circ}\text{C}$  and it is placed inside a hermetically sealed chamber of the satellite.

### 3 Basic functions of RT-2/E

In the power-on mode, all detectors detect X-rays and package them in a 'page' in the detector box itself, in a mode called the 'normal' mode, which can be changed to 'test' mode by command. Every second, RT-2/E sends a 'second' signal to the detectors and the data is sent to RT-2/E while the storing is done in a separate 'page' (these two pages toggle every second). RT-2/E processes the detector data and sends to the satellite. In RT-2/E, the data is made into packets with the processing intervals known as frames in whole (a number of packets as one frame) and each frame is divided into blocks. These blocks are compressed and are written in the memory of RT-2/E, in the form of packets. This telemetry data is subsequently sent to the satellite. Telecommands, which are up-linked to the satellite, include commands to adjust high voltage (HV), low level discriminator (LLD) value, Channel boundary change, 'mode' change and so on. All these commands are decoded within RT-2/E and are passed on to the respective detectors.

Another important task of the RT-2/E is to execute the pulse commands (SWITCH OFF/ON) that are available from the Control and communication unit (BUS-FM) of the satellite. The control commands (pulse commands) of the RT-2 system are discussed later on.

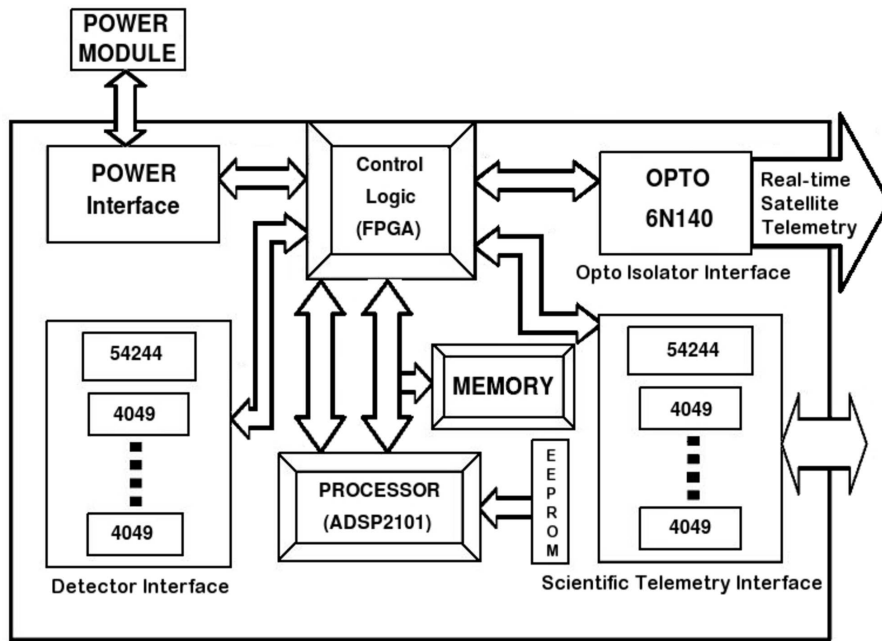

Fig. 2 Schematic block diagram of the processing electronic device RT-2/E.

#### 4 Role of RT-2 Onboard Software

The telemetry resources available for the RT-2 Experiment is 32 bits of satellite telemetry, read every 4 seconds and transmitted semi-continuously to the ground and 10 Mbytes of onboard memory, transmitted once or twice daily to the ground. The scientific requirement is to have coarse spectral and timing information of the X-ray data on a continuous basis and higher time resolution information during transient events. Further, it is also desirable to have faster read out of information for ground testing as well as for trouble shooting purposes. The onboard software needs to be parameterized so that a sufficient flexibility is available to change the working of the software based on a 16-bit data command and 14 'pulse commands'. For time synchronization, calibration time information is also available from the satellite subsystem SSRNI. This multiple and complex demands are realized in the following way:

- The asynchronous data from the X-ray detectors are packaged in the detector blocks themselves. This packaging is organized in two modes: a) a time tagged event mode to get 0.3 ms time resolution (to cater to any special needs like high time resolution study of some celestial objects and also for debugging the detector software) and b) a spectral and timing mode which has a time resolution better than what is scientifically required. Spectrum and image every second, and timing information every 10 millisecond, packaged every second are deemed to be sufficient to satisfy all the requirements. Time-stamping is done in the detector block using a local clock, and the data is interrogated and taken precisely every second, and this precision is established by taking this information from SSRNI. The detector performance and

software are controlled by a few data commands, designed as a subset of the 16-bit satellite data command.

- The basic detector data are packaged and kept in a memory in RT-2/E, to be transmitted to the satellite memory with its own protocol. This re-packaging is done based on modes and while transmitting, data are compressed using a loss-less compression code.
- The information from the detector is codified (8 bits per payload) and sent to the satellite telemetry every 4 seconds to have a basic diagnostic of the working of the experiment.
- The modes of operation is done based on ground commands as well as onboard processing. The onboard processing caters to a) flare detection b) memory availability c) satellite position (high and low background regions) and solar visibility.
- Facility is also kept to change the complete onboard software.

The data collected from the detectors is first taken into input buffers of RT-2/E memory and is accumulated in the accumulation buffers during a processing interval. On every processing interval boundary or on every processing mode change, the frame of data is compressed and made into packets by the onboard software. The algorithm used for loss-less compression of RT-2/E telemetry data is the CCSDS (Consultative Committee for Space Data Systems) recommended Rice algorithm (Yeh et al. 1991; Rice et. al. 1993). The compressed data is then sent to the satellite and then subsequently to the ground. Also, all the telecommands coming from the ground are decoded and appropriate commands are sent to the corresponding detectors.

The onboard flare detection logic is enabled every second. Satellite telemetry data is prepared by the software every second. Also, all the required functions are carried out on receiving the ON/OFF commands from the satellite.

Memory management scheme is included in the software, which does the work of managing the memory in RT-2/E. Further, CZT detectors initialization data is sent to CZT from the RT-2/E memory, on receiving CZT initialization command from ground. Watchdog timer updating logic is incorporated in the software, which will enable the hardware to reset the digital signal processor in case of software hang up.

There is an additional feature of downloading the contents of the program memory (onboard software) for verification. This can be enabled based on ground command. The onboard software is developed in the assembly language of ADSP2101 processor.

## 5 Modes of Operation

Based on the diverse constraints for using the satellite memory as well as requirement of the scientific interest, various processing modes are defined for RT-2/E.

### 5.1 Bad Mode (Mode Id = 0, 100 sec/frame)

The bad mode runs when the satellite enters into high flux region (South Atlantic Anomaly - SAA, North and South polar regions), based on signals from the satellite called 'GOOD' and 'BAD'. When RT-2/E is in this mode, the onboard software lowers the high voltage of Photomultiplier Tubes (PMT) of the Phoswich detectors and makes the HV of CZT detectors to zero and only the frame header data is transmitted but not

---

the detector data. When coming out of this mode i.e., to the good state, the previous modes are started afresh and the high voltage is set for the PMTs and CZT. The switch over to good mode from bad mode can be delayed by ground command as multiples of 64 seconds. In the bad mode, the data (header data) is sent every 100 seconds.

#### 5.2 Test Mode (Mode Id = 1, 1 sec/frame)

The software enters this mode, when the test mode data from the detectors are received. There will be house keeping data (VCO) and event data from the detectors, in this mode. The most significant bit of VCO data, if set, takes the software to this mode. The raw data from the detectors is sent to the satellite as soon as they arrive to RT-2/E, i.e., every second without any compression. There are also command based facilities to send a limited number of CZT events and also to send only the CMOS data.

#### 5.3 Debug Mode (Mode Id = 2, 1 sec/frame)

In this mode, the spectral data from detector units is sent to the satellite every second as soon as they arrive to RT-2/E. The purpose of this mode is debugging during the initial verification phase as well as in the case of any later malfunctions of either packages (payloads). RT-2/E is switched to the debug mode on commands from ground.

When RT-2/E is in the debug mode, there is an option to get the timing data alone from the detectors.

#### 5.4 Solar Quiet Mode - SQM (Mode Id = 4, 100 sec/frame)

This is the primary accumulation mode since the Sun is quiet in hard X-rays most of the time. In this mode, spectrum is obtained for every 100 second and count rates for every second in RT-2/S and G. Similarly, the spectra and the images in every 100 second and the count rates in every second are obtained for CZT detectors while only images are obtained for CMOS in every 100 second.

#### 5.5 Solar Flare Mode - SFM (Mode Id = 3, 10 sec/frame)

The major science requirement for this experiment is the availability of high temporal and spectral resolution data during solar flares. Since such flares occur randomly, the onboard software has a built-in mechanism for checking the current count rate against the present thresholds to detect the flares. The flare search is carried out at every second. The logic of flare detection will be discussed later. The data packaging is unaffected for RT-2/CZT during flares.

In this mode, data frame structure is identical to the solar quiet mode except that both the time resolutions are reduced by a factor of 10, i.e., in this mode, the count rates are stored at every 0.1 second and spectra are stored at every 10 second.

Normally, the data accumulation is done in the quiet mode. However, as soon as the flare trigger occurs, the current frame of the quiet mode is filled to the next multiple of 10 s. The quiet mode data till the detection of flare is made into packets and a new

frame is started in the flare mode. After trigger, the data is accumulated in this mode for next 10 second i.e., one frame. At the end of the frame, again flare threshold is checked and if the count rate is still more than that, then this mode will continue for another frame. Otherwise, the data accumulation will revert back to the quiet mode. Flare mode data frames are stored in the same address stream of data as the quiet mode.

### 5.6 Shadow Mode (Mode Id = 4, 100 sec/frame)

Shadow mode is activated when the Sun is out of the detector field of view i.e., during NIGHT and at the time of solar occultation. In this mode, flare detection is disabled. The processing of data in the shadow mode is similar to the solar quiet mode (SQM). The detector data are stored for every 100 seconds in blocks of 64 words. While transmitting, they are compressed and transmitted in packets of 60 words (59 words of data and one packet header). Also, for each type of data a separate packet called frame header is created.

For example, in the normal mode for RT-2/S and G, after decompression at ground, one frame data consists of 57 packets data (in RT-2/CZT 218 packets). Out of these 57 packets of data, first packet data is called frame header. Rest of the 56 packets contain scientific data. First word of each data packet is called packet header, it signifies current packet number out of total packets in the frame. The number of packets after decompression (60 words each) will be number of blocks before compression \* 64/59 + 1 and these values are estimated and given in Table 1.

**Table 1** Modes & packetisation of RT-2/S, RT-2/G and RT-2/CZT payload data

Processing Mode	Description	Compressed		Decompressed	
		S/G	CZT	S/G	CZT
Bad Mode	Frame Header, every 100 sec	-	-	1	1
Shadow mode	Spectrum every 100 sec	51	200	57	218
Test mode	Event data every sec	1-230	1-198	2-251	2-216
	Software download	-	64	-	71
Debug mode	Spectrum every sec	51	200	57	218
	Timing alone	13	19	16	22
Solar flare mode	Spectrum every 10 sec	51	-	57	-
Solar quiet mode	Spectrum 100 sec	51	200	57	218

### 5.7 Mode Selection Logic

The mode of operation of the experiment depends on the input from the satellite system (GOOD/BAD and LIGHT/SHADOW), data commands to the detector (to decide Test/Normal mode), data commands to the processor (to decide Normal/Debug mode), and onboard analysis (to decide memory availability and flare detection). Again, the flare detection logic can be fine-tuned using several data commands. Further, any of the data commands can be given in a time-tagged mode.

**Table 2** Good data condition for RT-2 payloads

GOOD/BAD	LIGHT/SHADOW	Detector Mode	Processor Mode	Flare detected	Output Mode
Bad	X	X	X	X	Bad
Good	X	Test	X	X	Test
Good	Shadow	Normal	Normal	X	SQM
Good	X	Normal	Debug	X	Debug
Good	Light	Normal	Normal	No	SQM
Good	Light	Normal	Normal	Yes	SFM

The selection logic for the Mode of operation is given in Table 2, which is valid when the available memory is  $>50\%$ . The letter ‘X’ in the table implies that the condition of that particular column is ignored to determine the Mode. The “BAD” condition is given the highest priority, when no scientific data is transmitted but only the frame header, i.e., one packet containing vital health parameters, is transmitted every 100 s. When the available memory is  $<25\%$ , the output is deemed to be in the Bad mode. The detector ‘Test Mode’ is given the next priority, when the output is in the ‘Test Mode’. This mode is enabled to directly get the detector data at higher time resolution for trouble-shooting purposes and hence very rarely used. Similarly, the ‘Debug Mode’ of the processor is used to directly transmit the detector data for trouble shooting purposes.

The normal mode of operation is the SQM. When the satellite is in the ‘Light’ region, the flare trigger is activated to take data transmission mode to SFM. Flare detection, however, is disabled when the available memory is below 50%. Sufficient care is taken such that the mode transitions do not cause any break in the data transmission (for example, when the data storing goes from SFM to SQM, it is done at an integer multiple of 10 seconds). Extensive and elaborate information is given in the header (see Table 20) so that the onboard logic which caused the mode transitions could be clearly understood.

## 6 Detector Data Formats

### 6.1 Data format for the RT-2/S and RT-2/G detectors

In the detector device, the asynchronous data from the NaI (Tl) / CsI (Na) crystals (Debnath et al. 2009) are stored in the memory. This data is transmitted to RT-2/E every second, based on a command from RT-2/E. Thus the asynchronous data from the detectors are sent in a synchronized manner for further processing.

The data storage occurs in two modes: i) test mode, where every event is time-tagged correct to 0.3 ms and ii) normal mode, where all the spectral data is accumulated and eight channel count rates are stored every 10 ms and sent in every second. The basic data (for each registered X-ray event) consists of pulse height (PH), pulse shape (PS), amplifier from which pulse height is determined (gain 1 - G1 or gain 2 - G2), and the time of registration of events. The detector box also creates histograms of pulse height depending on whether they are from NaI (Tl) or CsI (Na) (based on whether the pulse shape, PS, is less than a predetermined value,  $PS_{cut}$ ). Hence the highest time resolution possible from the experiment is: a) 0.3 ms in the event mode and b) 10 ms for



8 channel counters and c) 1 second for full spectrum. Apart from the detector data, the house-keeping (HK) information of the detectors is also sent to RT-2/E by encoding the information through a Voltage Controlled Oscillator (VCO). The spectral data is packaged in the detector device and dispatched to RT-2/E in the following format.

### 6.1.1 Test mode

Each detector ‘event’ is characterized by 2 words and event data structure is given in Table 3.

**Table 3** Event data structure of RT-2/S & RT-2/G.

D31-D20	D19-D13	D12	D11-D0
Time	Pulse Shape	G1 or G2	Energy

Maximum events that can be stored in memory are 7360 events. This data block is stored in a memory and sent to RT-2/E, whenever 1 second command is received. The channel number is incremented every second.

### 6.1.2 Normal mode

1. Header block (1 word): VCO data (2 bytes)
2. Spectrum block (2432 words): G1 Na (PH): 1K words; + G1 Cs (PH): 1 K words; + G2: 256 words; + width: 128 words.
3. Timing blocks (800 words): 100 Timing blocks X 8 counters X 1 word (counters in each block will count for 10 ms).
4. Counter block (8 words): 8 counters (1 word each)

The house-keeping data of Phoswich detectors (RT-2/S & RT-2/G) are multiplexed through VCO and stored in 8 channel format. The VCO data structure (2 byte) is given in Table 4.

**Table 4** VCO data structure of RT-2/S and G payloads.

D15	D14	D13-D11	D10-D0
Mode ID	Corona	VCO Channel No.	VCO Counts

The detail descriptions of eight VCO channels (HK parameter) is given in Table 5 (NC means Not Connected). One of these channel parameters is sent to RT-2/E through VCO every second.

Note: VCO frequency (2 kHz min. to 20 kHz max.) is corresponding to 1 to 10 Volt variation.

## 6.2 Data format for the RT-2/CZT detector

In the detector block, the asynchronous data from the CZT detectors (Kotoch et al. 2009) are stored in memory. This data is transmitted to RT-2/E every second, based

**Table 5** HK parameters of RT-2/S and G payloads.

Channel No.	Description	Voltage level
0	Supply Voltage	+ 5V $\pm$ 0.5V
1	Thermistor	+ 1.5V - +5.0V
2	Supply Voltage	+ 5V $\pm$ 0.5V
3	NC	-
4	HV Feedback	+ 1.5V - +5.0V
5	HV Reference	+ 1.5V - +5.0V
6	LLD Voltage	+ 1.5V - +5.0V
7	NC	-

on 1 second command from RT-2/E. Thus the asynchronous data from the detectors are sent in a synchronized manner for further processing.

The data storage occurs in two modes: i) test mode where every event is time-tagged correct to 0.3 ms and ii) normal mode, where all the spectral and image data are accumulated and count rates are stored every 10 ms and sent in every second. Hence the highest time resolution possible from the RT-2/CZT is: a) 0.3 ms in the event mode and b) 10 ms for 12 channel counters and c) 1 second for full spectrum and image. Apart from the detector data, the House-Keeping (HK) information of the detectors is also sent to RT-2/E by encoding the information through an ADC.

RT-2/CZT is set to command mode by ground command before issuing commands to individual CZT modules. For CZT, the ADC value corresponding to each pixel is multiplied by a gain factor 1.xx, where 'xx' varies from 0 - 0.25 in steps of 0.001 (to correct the errors in the energy range and count ratio of pixels). Then a constant value (CZT constant can be commanded from ground) is subtracted from this. This constant is the same for all pixels. Further, an offset value is added to this. Offset is an 8 bit number and can be different for each pixel.

- Pixel value (CZT) = (ADC O/P value) \* gain - CZT constant + offset

Here, the 'CZT constant' is subtracted to account for the sign of the offset value. The optimum gain and offset values for each pixel is stored in the gain-offset table within the CZT memory. The ADC value, after applying these operations is used for image and spectrum computation in the normal mode. In the test mode, upper 10 bits of the actual ADC value (12 bits) are used in the event data.

For CMOS detector, 512 x 1024 pixel values are read periodically and a CMOS constant (which can be changed by ground command) is subtracted from the ADC value corresponding to each pixel.

- Pixel value (CMOS) = (ADC O/P value) - CMOS constant

An upper threshold value is also defined (ground command) and if the pixel value crosses this threshold, the value is zeroed, considering it as a bad pixel. For 1-bit image, if the value crosses a threshold (defined separately for each line), the value is 1, else 0.

Bit image of the CMOS detector is made by applying logical OR to the values of four adjacent (2x2) pixels. This is done for 512 x 512 pixels, starting from a start line. Start line and line thresholds can also be changed by command. This results in a 256 x 256 1-bit image. The sum of all vertical pixels and horizontal pixels are computed separately (before 'OR'ing) as  $V_{sum}$  and  $H_{sum}$  respectively.

In CMOS, frames (each scanned image) are obtained depending on the frame interval provided. Frame interval is the time set to get a frame from the detector, which is

selectable from ground. For example, if the frame interval is set for 4 seconds, a frame is obtained every 4 seconds. Frames are integrated in the detector itself during this interval. In the test mode, all the frames received in every 32 seconds are integrated within RT-2/CZT and the integrated data is sent to RT-2/E in 32 second (data of 8k pixels in each second). The possible frame intervals in normal mode and test mode are given in Table 6.

**Table 6** Frame Intervals in Normal and test modes of RT-2/CZT (CMOS detector).

Normal Mode	Test Mode
1	1
2	2
4	4
5	8
10	16
20	32
25	-
50	-
100	-

#### CMOS Calibration:

Calibration of CMOS pixels can be done in the test mode of RT-2/CZT. Data of N consecutive image frames are averaged and these frames are taken, where N is 32 divided by the frame interval, defined in the previous table. The calibration result is written in 256  $V_{sum}$  locations, two values in each word. The calibration result is identified by '1' in the location 8182 of RT-2/CZT data. Addition of an offset value to the calibrated results can also be done by command in normal or test mode.

The contents of RT-2/CZT EEPROM can be sent as data to RT-2/E in test mode, on receiving the command 0x4803. The data from RT-2/CZT is sent to RT-2/E every second in the following format.

#### 6.2.1 Test mode

Each CZT 'event' is characterized by 2 words and event data structure is given in Table 7. This data is stored in the memory and sent to RT-2/E, every second. Maximum events that can be stored in memory are 4032 events.

**Table 7** Event data structure of RT-2/CZT detector

D31-D20	D19-D10	D9-D2	D1-D0
Time	ADC value of Detector data	Pixel ID	Detector No. (0-2 for 3 CZTs)

### 6.2.2 Normal mode

The normal mode data format for CZT (3 modules) and CMOS detector is given below:

#### Data of CZT:

1. Image block (3072 words): 1 K words per CZT (4 channel X 256 pixels X 1 word).
2. Spectrum block (1536 words): 512 words per CZT
3. Timing blocks (1200 words): 3 CZT detector X 100 timing words X 4 channels X 1 word (counters in each block will count for 10 ms).
4. Counter block (24 words): 12 counters (2 words each)
5. VCO block (1 word): 2 bytes of ADC data
6. Special words (8 words) : Satellite telemetry word, temperature, Command sent, Data read against command, event number , CMOS line number, Calibration result identification word and Calibration status

#### Data of CMOS:

1. Image block (4096 words): 256 x 256 pixels
2. Sum (512 words): Vertical sum (256 words) + Horizontal sum (256 words)

The house-keeping (HK) data of CZT-CMOS detector (RT-2/CZT) are multiplexed through an ADC and HK parameters are stored in 8 channel format. The ADC data structure is given in Table 8.

**Table 8** ADC data structure of CZT-CMOS detector

D15	D14	D13-D11	D10-D0
Mode ID (0: Normal, 1: Test)	1: EEPROM, 0: Detector	ADC Channel No.	ADC Counts

The detail description of eight ADC channels (HK parameter) is given in Table 9. One of these channel parameters is sent to RT-2/E through ADC in every second.

**Table 9** HK Parameters of RT-2/CZT payload

Channel No.	Description	Voltage level
0	Supply Voltage	+ 5V $\pm$ 0.5V
1	Thermistor	+ 2.5V - +5.0V
2	NC	-
3	NC	-
4	HV Control	0.0/3.3V
5	CZT Supply (DVDD)	+ 3.6V
6	CMOS Supply	+ 5.0V
7	FPGA core Supply (Vcca)	+ 2.5V

Note: In 'command' mode of CZT, Data read against CZT detector commands comes in the special words.

## 7 Accumulation of Detector Data

Data from the detectors are first fed to the input buffers, where the spectral data / event data of the detectors are buffered. There are two separate buffers for each detector. Data is written alternately into each buffer. FPGA writes the detector data to one of the buffers and the processor reads the data from the other buffer. The allocation of all three detector data in normal mode is discussed in the following sections.

### 7.1 Input buffer of RT-2/S & RT-2/G:

A total of 3328 words of memory space are allocated for the RT-2/S and RT-2/G detectors data in the input buffers. Data structure in the input buffer is given in Table 10.

**Table 10** Data structure of the input buffers of RT-2/S & RT-2/G:

Address	Data Type	Data (words)
0-1023	NaI Spectrum	1024
1024-2047	CsI Spectrum	1024
2048-2847	Timing	800
2936-2943	Total Counts	8
2944-3071	PSD Spectrum	128
3072-3327	G2 Spectrum	256

### 7.2 Accumulation buffer of RT-2/S & RT-2/G

The data from the input buffers is accumulated in an accumulation buffer. A total of 3248 words of memory space are allocated for the RT-2/S and RT-2/G detectors data in the accumulation buffers. The data allocation in this accumulation buffer is given in Table 11.

**Table 11** Data structure of the accumulation buffer of RT-2/S and RT-2/G

Address	Data Type	Data (words)
0-1023	NaI Spectrum	1024
1024-2047	CsI Spectrum	1024
2048-2303	G2 Spectrum	256
2304-2431	PSD Spectrum	128
2432-3231	Timing	800
3232-3247	Counts	16

The 8 extra words in the accumulation buffer are to accommodate deeper (2 words each) accumulation of counters.

### 7.3 Input buffer of RT-2/CZT:

RT-2/CZT is an imaging device. It has two different type of detectors, namely CZT and CMOS. The image, spectrum and timing data allocation of CZT of RT-2/CZT in input buffers is described in Table 12.

**Table 12** Data structure of CZT in RT-2/CZT payload.

Address	Data Type	Data (words)
0-4095	Image	4096
4096-6143	Spectrum	2048
6144-7343	Timing	1200
7744-7767	Counts	24
8176	CZT Satellite Telemetry word	1
8177	Temperature	1
8178	CZT Command	1
8179	Data read against Command	1
8180	Event Number	1
8181	CMOS line Number	1
8182	1: Threshold calibration result in vertical sum location	1
8183	0: CMOS calibration	1

In the input buffer, 8 words are assigned for 'some' special informations (see Table 12) for RT-2/CZT. Description of special words are given below:

Temperature word:

Bits 7-0 : Temperature, Bits 9-8 : CZT number, Bits 13-10 : 0xF valid data, Bits 15-14 : base address of RT-2/CZT EEPROM

Event number:

Bit 15 : CZT3 ON, Bit 14 : CZT2 ON, Bit 13 : CZT1 ON, Bits 12-0 : (number of events)/64

Line number:

Bits 7-0 : CMOS line number, Bits 15-8 : frame interval

CMOS detector has only image information. A total of 4608 words of memory space are allocated for CMOS detector data in the input buffers. The image data allocation of CMOS detector in input buffer is given in Table 13.

**Table 13** Data structure of CMOS detector data

Address	Data Type	Data (words)
8192 - 12287	Image	4096
12288 - 12799	Sum	512

#### 7.4 Accumulation buffer of RT-2/CZT:

A total of 5832 words of memory space are allocated for CZT detector data in the accumulation buffers. Data allocation structure in accumulation buffer is given in Table 14.

**Table 14** Data structure in accumulation buffer for CZT of the RT-2/CZT detector.

Address	Data Type	Data (words)
0 - 3071	Image	3072
3072 - 4607	Spectrum	1536
4608 - 5807	Timing	1200
5808 - 5831	Counts	24

Data allocation of CMOS detector in accumulation buffer is identical as of input buffer and data structure is given in Table 15.

**Table 15** Data structure of CMOS of RT-2/CMOS

Address	Data Type	Data (words)
8192 - 12287	Image	4096
12288 - 12799	Sum	512

During test mode, data in input buffer of RT-2/CZT is read by RT-2/E for telemetry and in normal mode, data in accumulation buffer for telemetry. The allocation of RT-2/CZT data in RT-2/E input buffer in test mode is given in Table 16.

**Table 16** Structure of the allocation of RT-2/CZT data in RT-2/E.

Address	Data Type	Data (words)
0 - 8063	CZT Event reports	8064
8176 - 8183	CZT Special words	8
0 - 8192	EEPROM data	8192
8192 - 12287	CMOS test data	4096
12288 - 12543	CMOS calibration results	256

## 8 Data Compression Scheme

RT-2 telemetry data is subjected to loss-less data compression, for effective bandwidth as well as memory utilization. Each frame of data is divided into different blocks, each block of size 64 words. Each block is compressed, made into packets and then written to RT-2/E memory. CCSDS recommended Rice Algorithm (Yeh et al. 1991; Rice et. al. 1993) is used for compression. There are various compression options in the algorithm,

the best-suited option for each block is decided onboard and the selected option is used for compressing the block of data. If compression is not achieved for the data block, actual data will be sent. The compressed data is made into packets and is written in the memory. Total data size in each frame, number of compressed block and block size is summarized below:

- Number of telemetry data per frame: 3248 words for RT-2/S & RT-2/G, 12800 words (including 7760 words for CZT, and 4608 for CMOS) for RT-2/CZT, 4096 Program memory words.
- Number of blocks to be compressed: 51 for RT-2/S & RT-2/G data, 200 for CZT data, 64 for Program memory data.
- Block size: 64

Each block data contains a block header of one word followed by the compressed data and is written in the packet. Flow chart to compress data is given below:

- Get blocks of data
- Set first sample as the reference sample
- Check the difference between successive samples
- Select the best compression option for the block
- Compress the differences using the best option
- Packet the compressed data

### 8.1 Compression Options:

The block header word (16 bits) of each block has the following information:

Bits 15-8: Compression option, Bits 7-0: Block number.

The difference of adjacent samples in each block is computed and the difference values are coded using the best option given in Table 17.

**Table 17** Compression options of RT-2/E telemetry data.

Option No.	Option
0	16:0
1	15:1
2	14:2
4	12:4
5	zero block
6	No compression

#### **No compression option**

When this option is chosen, the data consists of block header followed by 64 data samples of the block.

#### **Zero block**

When all the samples in the block are the same, all the difference values will be zeroes. In this case, this option is chosen. Here, for each block, compressed data consists of one block header followed by the first sample of the block.



**16:0 option**

Here, difference value as such will be coded using Rice code.

**15:1 option**

In this option, each difference value/2 is encoded using Rice code. The LSB of the difference is appended as such. Thus, for a block, compressed data consists of three parts - block header, Rice codes of all the differences and followed by the LSBs (Least Significant Bit) of all differences. The LSBs are packed into words and written, starting from a fresh word. In this option, there will be 4 LSB words, following the encoded data.

**14:2 option**

In this option, each difference value/4 is encoded using Rice code. The two LSBs of the difference is appended as such. In this option, there will be 8 LSB words, following the block header and encoded data.

**12:4 option**

In this option, each difference value/16 is encoded using Rice code. The four LSBs of the difference is appended as such. In this option, there will be 16 LSB words, following the block header and encoded data.

The fundamental sequence of Rice code is given in Table 18.

**Table 18** The fundamental sequence in the Rice code.

Value	Code
0	1
1	01
-1	001
2	0001
-2	00001
.	.
.	.

## 9 Packeting Scheme

The detector data, after compression, is written in RT-2/E memory in the form of packets. Each frame data results a number of packets, having 60 words (960 bits) each. Out of these packets, first packet is frame header and the remaining packets are data packets. Frame header is written into memory as such without compression. All data packets (from second packet) consist of compressed data. First word of each data packet is the packet header.

The packet header (Table 19) will have the packet number and the location where the next block of compressed data starts in the packet. If there is no new block data in the packet, this number will be zero. The packet header location in the first packet (frame header) will always be 0x0101.

The description of the 60 words (1 packet) in the frame header is given in the Table 20, 21 and 22.

**Table 19** Packet header in RT-2/E memory.

Bit No.	Description
15 - 8	Packet number
7 - 0	Starting location of first block of compressed data

## 10 Satellite Interface

A sophisticated interface scheme is provided for RT-2/E with the Coronas-Photon satellite. Satellite interface scheme includes pulse commands and power ON/OFF for RT-2 payloads, telecommand interface line, scientific telemetry for down link detector data and ‘real-time’ satellite telemetry to have instruments health informations in every 4 seconds. Details of satellite interface with RT-2/E and specific requirements are discussed below:

1. Power and Pulse Commands (PC) for ON/OFF (14 contact commands):

These commands are required for power ON/OFF of the instruments and selection of GOOD/BAD operating region in the satellite orbit. All command informations are summarized in the Table 23.

2. Data commands (16 bits):

To have the redundancy in telecommand, two separate telemetry interfaces 19 and 20 are provided for each telecommand chain i.e. 5 lines X 2 parallel (‘AND’ed). These are the five parallel lines, which are named as ‘one second command’, ‘time sync’, ‘command sync’, ‘clock’, ‘serial data’ for telecommands transmitted in two independent channels.

3. Scientific telemetry:

Scientific telemetry is the transmission of the scientific (spectral/event) data from the detectors. Detector data are packetized in RT-2/E depending on the processing mode. This scientific telemetry is done in two separate telemetry channels TM1 (for RT-2/S and RT-2/G) and TM2 (for RT-2/CZT).

4. Satellite telemetry (32 bits):

Satellite telemetry is a ‘real-time’ telemetry scheme, which sends the data (health parameters) in each 4 second. Satellite telemetry is done in 32 bits (total) - 8 bits for three detectors (S, G and CZT) and for the electronics device (RT-2/E), which are sent every 4 second. In these 32 bits, 15 bits are allotted for the three 5 bit counters (S, G and CZT), 3 bits for 3 VCO bytes converted into bits and 8 bits for the parameters (status of memory, orbit etc.) in RT-2/E. Four digital channels, each of 8-bit wide are used to sent the informations to the satellite telemetry by RT-2/E. In Table 24, all informations are summarized.

## 11 Ground Commands

There will be certain situations to adjust some parameters like the high voltage to the PMT, the LLD value and channel boundary value. These can be done from ground by sending commands to the satellite. Also, the data transfer and mode selection are done by the ground commands. All detector commands are passed through the RT-2/E processing device. Details of detector commands are summarized in respective papers (Debnath et al. 2009; Kotoch et al. 2009). RT-2/E commands are summarized in Table

25. These commands include processor mode selection (SFM, SQM, Debug, Test etc.) with different condition, Flare selection logic for S and G, resetting the RAM, BAD to GOOD time set duration etc.

## 12 Flare Detection

RT-2/E has onboard flare detection logic, which is executed every second. RT-2/E software switches to Solar Flare Mode (SFM) or back to Solar Quiet Mode (SQM) based on the solar mode detected on every 10 second boundary. The solar mode is decided based on the data from RT-2/S and RT-2/G. There are two options by which the solar mode is decided:

1. When RT-2/S or RT-2/G, any of them gives flare data.
2. When RT-2/S and RT-2/G, both give flare data.

Either of these two options can be chosen by ground command. The commands 0xE000 and 0xE001 choose 'or' logic and 'and' logic respectively. Once the solar mode is decided based on the logic, both RT-2/S and RT-2/G data is processed in the same mode, Solar Flare Mode (SFM, processing every 10 second) or Solar Quiet Mode (SQM, processing every 100 second).

Flare detection every second is done based on the accumulated values of C1, C2 and C5 counts (Scientific data are accumulated in 8 counters, for details, see Debnath et al. 2009) during the last three 100 ms intervals within the second. If the sum of the accumulated C1, C2 and C5 counts exceeds a set threshold value ( $F_{th}$ ) in all these three intervals, then a flare is identified. These threshold values can be changed by command. Else, if the counts have not even exceeded the threshold at least once, then the data are assumed to be solar quiet data. Independent threshold values can be given for RT-2/S and RT-2/G. The commands for default threshold are 80FF and A0FF (see Table 25). The default value of both these thresholds is 0xFF, which means that the count rate should be  $\geq F_{th} \times 32$  i.e.  $255 \times 32 = 8160$ . Flare detection logic applies to RT-2/S and RT-2/G data only.

## 13 Discussions and Concluding Remarks

In a series of papers on RT-2 Experiment onboard the Coronas-Photon satellite, we have described the technical details as well as the test and evaluation methods. In the present paper, we have discussed the processing electronic device (RT-2/E) of RT-2. On 30th of January, 2009, the CORONAS-PHOTON was launched successfully and all the RT-2 payload components including RT-2/E are working to our satisfaction. The Data Structure and Data Management softwares are working as per plan as verified by the onboard Data status.

The onboard performance of the software was found to be very satisfactory. Since most of the data are slowly varying, a factor of 3 compression could be obtained, mostly with 15:1 or 14:2 options. In the initial days of operation, the detectors were operated without applying the High Voltages to verify the satisfactory response to the BAD signals from the satellite. Once these aspects are correctly established, the detectors were operated in the SQM (by deliberately keeping the flare threshold high and not allowing any flare detection). It was found that the onboard memory was adequate. The 'Test Modes' were operated to calibrate the CMOS detectors as well as to make

high time resolution observations of the Crab Nebula. In this mode, however, memory full signal was noticed and the system was going to the 'BAD' mode. In the subsequent operations of the 'Test modes', duration of these modes are restricted by time-tagged commands to avoid memory overflow. Once full confidence in the overall working of the instrument was established, the flare detection logic was enabled with appropriate flare threshold commands (Instruments were operated with 0x8002 command for flare threshold value  $F_{th} = 2$  with count rate 64). The system was going to SFM during about 30% of time, mostly due to the flare triggers encountered during high background regions. The details of the on board data calibration would be discussed elsewhere.

**Acknowledgements** DD and TBK thank CSIR/NET scholarships and RT-2/SRF fellowship (ISRO) which supported their research work. The authors are thankful to scientists, engineers and technical staffs from TIFR/ICSP/VSSC/ISRO-HQ for various supports during RT-2 related experiments.

## References

1. Debnath, D., Nandi, A., Rao, A. R., Malkar, J. P., Hingar, M. K., Kotoch, T. B., Sreekumar, S., Madhav, V. P., Chakrabarti, S. K.: Instruments of RT-2 Experiment onboard CORONAS-PHOTON and their test and evaluation I: RT-2/S and RT-2/G Payloads, *Exp. Astron.* (2010, in press).
2. Kotoch, T. B., Nandi, A., Debnath, D., Malkar, J. P., Rao, A. R., Hingar, M. K., Madhav, V. P., Sreekumar, S., Chakrabarti, S. K.: Instruments of RT-2 Experiment onboard CORONAS-PHOTON and their test and evaluation II: RT-2/CZT Payload, *Exp. Astron.* (2010, in press).
3. Kotov, Yu., Kochemasov, A., Kuzin, S., Kuznetsov, V., Sylwester, J., Yurov, V.,: Set of instruments for solar EUV and soft X-ray monitoring onboard satellite Coronas-Photon. In 37th COSPAR Scientific Assembly, in Montral, Canada., p.1596 (2008)
4. Nandi, A., Palit, S., Debnath, D., Chakrabarti, S. K., Kotoch, T. B., Sarkar, R., Yadav, V. K., Girish, V., Rao, A. R., Bhattacharya, D.: Instruments of RT-2 Experiment onboard CORONAS-PHOTON and their test and evaluation III: Coded Aperture Mask and Fresnel Zone Plates in RT-2/CZT Payload *Exp. Astron.* (2010, in press).
5. Nandi, A., Rao, A. R., Chakrabarti, S. K. et. al.: Indian Payloads (RT-2 Experiment) onboard CORONAS-PHOTON Mission. In *Proc. of International Conference on Space Technology, Greece, G. Lampropoulos and M. Petrou (Eds.) (2009a)* (arXiv:0912.4126)
6. Rice, R. F., Yeh, Pen-Shu and Miller, W. H.: Algorithms for high speed universal noiseless coding module. In *Proc. of the AIAA Computing in Aerospace Conference, San Diego, CA, (1993)*
7. Sarkar, R., Mandal, S., Debnath, D., Kotoch, T. B., Nandi, A., Rao, A. R., Chakrabarti, S. K.: Instruments of RT-2 Experiment onboard CORONAS-PHOTON and their test and evaluation IV: Background Simulations using GEANT-4 Toolkit, *Exp. Astron.* (2010, in press).
8. Yeh, Pen-Shu, Rice, R. F. and Miller, W. H.: On the optimality of code options for a universal noiseless coder. NASA JPL Publication, 91-2, (1991)

**Table 20** Description of the frame header in RT-2/E memory.

Word No.	Description	Remarks
0	Packet header - 0x0101	-
1	Detector ID	0: RT-2/S, 1:RT-2/G, 2:RT-2/CZT, 3: EEPROM packet
2	Frame No.	No. of current frame
3	Time duration of frame	sec
4	Time LSB	Time in sec.
5	Time MSB	Time in sec.
6	GPS Time LSB (interface19)	From LSB: 10 bits: millisec; 6 bits: sec
7	GPS Time MSB (interface19)	6 bits: minutes; 5 bits: hours; 5 bits: days
8	GPS Time LSB (interface20)	From LSB: 10 bits: millisec; 6 bits: sec
9	GPS Time MSB (interface20)	6 bits: minutes; 5 bits: hours; 5 bits: days
10	Read packet number - Telemetry1 (TM1)	Number of packets read from TM1 memory
	Read packet number - Telemetry2 (TM2)	Number of packets read from TM2 memory
11	Write packet number - Telemetry1 (TM1)	Number of packets written in TM1 memory
	Write packet number - Telemetry2 (TM2)	Number of packets written in TM2 memory
12	Processing mode ID	0: Bad mode, 1: Test mode, 2: Debug mode, 3: SFM, 4: SQM
13	Bit14 - second select	0: sec in interface19, 1: sec in interface20
	Bit13 - good veto	1: veto good, 0: otherwise
	Bit12 - bad veto	1: veto bad, 0: otherwise
	Bit11 - light veto	1: veto light, 0: otherwise
	Bit10 - shadow veto	1: veto shadow, 0: otherwise
	Bit9 - millisecond select	0: ms in interface 19, 1: ms in interface 20
	Bit8 - GPS valid	1: valid GPS in interface20, 0: invalid GPS in interface 20
	Bit7 - second boundary flag for interface20	1:second boundary
	Bit6 - command flag for interface20	1 when received, 0 when not received
	Bit5 - 4	unused bits
	Bit3 - solar mode	1: flare mode, 0: quiet mode
	Bit2 - processor mode	1: debug mode, 0: normal mode
	Bit1 - corona	1: corona
	Bit0 - detector mode	1: test mode, 0: normal mode
14	Status port1*	*See Table 21
15	Satellite Telemetry LSB	Telemetry channels of RT-2/G and RT-2/S
16	Satellite Telemetry MSB	Telemetry channels of RT-2/E and RT-2/CZT
17	Data Count	Count of data received from detector input buffer
18	Flare Threshold	Value of the threshold set (0-255) (Fth) if $(C1+C2+C5)/32$ (sum count rate) $\geq$ Fth, then flare flag set
19	High Voltage command	Current command given for HV
20-27	VCO data (8 words)	VCO channels of the detectors
28	Memory availability**	**See Table 22
29	Ground command	Last ground command given
30	Bit15 (CZT and CMOS data flag)	1: CMOS data alone in CZT test mode 0: CZT+CMOS data in CZT test mode
	Bit14 (Timing flag)	1: timing alone in debug mode, 0: all data in debug mode
	Bit13-0 (Number of event data)	Valid only in test mode
	<b>RT-2/S &amp; RT-2/G</b>	
31-46	Total counts (16)	C1-C8 counter values, 2 words for each counter
47-59	Ground commands (13)	13 Ground commands given lastly
	<b>RT-2/CZT</b>	
31-54	Total counts (24)	C1-C12 counter values, 2 words for each counter
55-59	CZT data (5)	Word 55: Temperature, Word 56: command Word 57: data read against command Word 58: event number, Word 59: CMOS line number

**Table 21** \*Status Port1

Bit No.	Description	Remarks
15-7	Unused	-
6	Memory area	0: section1, 1: section2
5	GPS valid (interface19)	0: valid GPS, 1: invalid GPS
4	Input buffer select	0: buffer1, 1: buffer2
3	Second flag (interface19)	1: second boundary
2	Command (interface19)	1: command received, 0: otherwise
1	Good/Bad	0: Good, 1: Bad
0	Light/Shadow	0: Light, 1: Shadow

**Table 22** \*\*Memory availability

Bit No.	Availability	Processing modes supported
0	≥50%	All modes
1	50%	All except SFM
2	25%	Bad mode
3	Nil	No data

**Table 23** Power and Pulse commands of RT-2 operation

Contact Identification	Contact	Contact type
PC124	Power ON (RT-2)	Executed in BUS-FM
PC125	Power OFF (RT-2)	Executed in BUS-FM
PC130	Switch ON (RT-2/S)	Pulse dry contact
PC131	Switch OFF (RT-2/S)	Pulse dry contact
PC132	Switch ON (RT-2/G)	Pulse dry contact
PC133	Switch OFF (RT-2/G)	Pulse dry contact
PC134	Switch ON (RT-2/CZT)	Pulse dry contact
PC135	Switch OFF (RT-2/CZT)	Pulse dry contact
PC136	Change Operational Mode	Pulse dry contact
PC137	RESET RT-2	Pulse dry contact
PC147	LIGHT	Continuous dry contact
PC148	SHADOW	Continuous dry contact
PC149	BAD	Continuous dry contact
PC150	GOOD	Continuous dry contact

**Table 24** Description of Satellite Telemetry bits (32 bits)

Bit No.	Description	Remarks
<b>RT-2/S</b>		
0	+5 V	1 = +5V, 0 = 0V
1	Corona ON/OFF	1 = Corona ON, 0 = Corona OFF
2	HV Feedback	1 = HV ON, 0 = HV OFF
3 - 7	5 bit counter	(C1+C2+C5)/32
<b>RT-2/G</b>		
8	+5 V	1 = +5V, 0 = 0V
9	Corona ON/OFF	1 = Corona ON, 0 = Corona OFF
10	HV Feedback	1 = HV ON, 0 = HV OFF
11 - 15	5 bit counter	(C1+C2+C5)/32
<b>RT-2/CZT</b>		
16	+5 V	1 = +5V, 0 = 0V
17	Command mode: CZT status Event mode: Sum of Vsum EEPROM data read mode	1 = Command sent to Detector, 0 = Command not sent 1 = sum of Vsum > threshold, 0 = sum of Vsum < threshold Bit 1 of data in address 8176 of EEPROM*
18	HV Feedback	1 = HV ON, 0 = HV OFF
19 - 23	5 bit counter In EEPROM read mode	(Channel2 count of CZT1)/32 bits 3-7 of data in address 8176 of EEPROM*
<b>RT-2/E</b>		
24	LIGHT/SHADOW	1 = SHADOW, 0 = LIGHT
25	GOOD/BAD	1 = BAD, 0 = GOOD
26	Flare	1 = ON, 0 = OFF
27	+5 V	1 = +5V, 0 = 0V
28 - 29	Memory availability (TM1)	0 = >50%, 1 = 50%, 2 = 25%, 3 = NIL
30 - 31	Memory availability (TM2)	0 = >50%, 1 = 50%, 2 = 25%, 3 = NIL

\*These slots can be used to verify EEPROM lock/unlock.

**Table 25** Ground commands of RT-2/E

Command Type	Command	Description
Normal mode (RT-2/S)	0x80xx	Set RT-2/S in normal mode with flare threshold of xx
Debug mode (RT-2/S)	0x8800	Set RT-2/S in debug mode to get all the data from it
Debug mode with timing alone (RT-2/S)	0x8801	Set RT-2/S in debug mode to get timing data alone from it
Test mode with 'n' events (RT-2/S)	0x89xx	Set RT-2/S in test mode, d6-d0: no. of events/64
Normal mode (RT-2/G)	0xA0xx	Set RT-2/G in normal mode with flare threshold of xx
Debug mode (RT-2/G)	0xA800	Set RT-2/G in debug mode to get all the data from it
Debug mode with timing alone (RT-2/G)	0xA801	Set RT-2/G in debug mode to get timing data alone from it
Test mode with 'n' events (RT-2/G)	0xA9xx	Set RT-2/G in test mode, d6-d0: no. of events/64
Normal mode (RT-2/CZT)	0xC000	Set RT-2/CZT in normal mode
Debug mode (RT-2/CZT)	0xC800	Set RT-2/CZT in debug mode to get all the data from it
Debug mode with timing alone (RT-2/CZT)	0xC801	Set RT-2/CZT in debug mode to get timing data alone from it
Test mode, only CMOS	0xC9FF	Set RT-2/CZT in test mode to get CMOS data only
Test mode, CZT + CMOS	0xC97F	Set RT-2/CZT in test mode to get CZT and CMOS data only
Test mode, only CZT with 'n' events	0xC9xx	Set RT-2/CZT in test mode to get events alone, d6-d0: no. of events/64
Initialization data dump to CZT	0xC400	Dumping initializing data into CZT
RAM address select for RT-2/E	0xDxxx	Select the 12 bit address in RAM, xxx: 12 bit address
Flare decision logic command	0xE000	Flare data from S 'or' G
	0xE001	Flare data from S 'and' G
RAM reset	0xE002	Reset RAM
PGM memory data to RAM	0xE003	Get data from program memory to RAM
RAM data to packets	0xE004	Get data from RAM (page 62) in packets
Bad to good duration set command	0xE1xx	d7-d5: no. of seconds/64
		d4: second select (0: interface19, 1: interface20)
		d3-d0: veto_GBLs (good, bad, light, shadow veto)
RAM data write in RT-2/E (8 bit value)	0xE2xx	-