



## COUPLINGS WITH VARIABLE CHARACTERISTICS OF VEHICLES

Brosnislovas Spruogis<sup>1</sup>, Arūnas Jakštas<sup>2</sup>

*Dept of Transport Technology Equipment, Vilnius Gediminas Technical University,  
 Plytinės g. 27, LT-10105 Vilnius-16, Lithuania*

*Received 2004-09-10 ; accepted 2004-12-03*

**Abstract.** Couplings abruptly changing their torsional rigidity and carrying capacity when the transmitted torque reaches a particular value are considered. This state is achieved either changing the conditions of the deformation of a flexible member or by excluding it from torque transmission. In the presented paper the conditions of mode variation are determined and some relationships for determining major parameters of couplings are given.

**Keywords:** coupling, bearing capacity, rigidity, allowable stresses.

### 1. Introduction

A coupling is one of the structural elements determining the performance of vehicles. It connects the transmission and the drive wheels. A vehicle operates under complicated conditions when mechanical forces acting on its units vary depending on the particular road and mode of operation. Vibration isolation of vehicles is largely determined by coupling flexibility. The requirements which couplings should meet are determined by traffic conditions and operation modes. Thus, operating in an emergency mode couplings should be capable of transmitting the maximum torque, while the vibration isolation requirement is not so important. Under ordinary traffic conditions more flexible couplings are preferred to achieve higher comfortability. Therefore, couplings which change their carrying capacity and rigidity depending on loading are more preferable for commonly used transport facilities.

Now various methods of altering coupling characteristics are known. Thus, load-carrying capacity can be altered by pouring the magneto-rheological liquid in the space between the parallel surfaces of the driving and driven half-couplings [1]. However, in this case torsional coupling rigidity is but slightly changed, while its vibration isolation is still insufficient at variable frequency of disturbance found when traffic speed or road profile are changed.

Vehicle transmission with controlled parameters is obtained by introducing a variator [2] into its de-

sign which helps to change the carrying capacity of the system, while its rigidity remains unchanged.

The problems of improving service conditions of vehicles by using controlled hydraulic transmission are considered. However, in this work the emphasis is also placed on the optimization of carrying capacity.

### 2. Couplings with flexible ring elements

In this type of couplings a torque is transmitted via a ring connected with a hinge to the driving and driven half-couplings. When torque reaches a particular magnitude a flexible member is either unloaded or its deformation conditions are changed.

In the first case (see Fig 1) a coupling is the combination of the ring and tooth-type couplings.

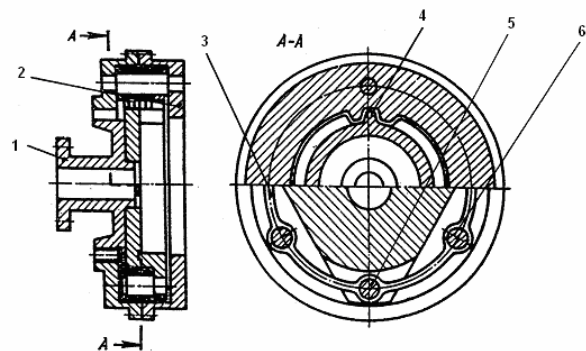

**Fig 1.** A schematic diagram of a tooth-type ring coupling: 1 – driving half-coupling, 2 – driven half-coupling, 3 – a flexible ring, 4 – tooth gearing, 5 – a pin connecting the ring with the driving half-coupling, 6 – a pin connecting the ring with the driven half-coupling

<sup>1</sup> E-mail: bs@ti.vtu.lt

<sup>2</sup> E-mail: arunas@me.vtu.lt

When the torque is small the loading is transmitted via a flexible ring. A distinctive feature of the engagement used in this coupling compared to commonly used mesh is the absence of every other tooth of the rings. Half-couplings are arranged in such a way that, when not loaded, teeth may engage only when the torque achieves a particular value because the gap between them is the largest at that time. When the torque is being transmitted normal stresses occur in the ring due to the following factors:

- a) a bending moment caused by a useful load

$$M_B = a \cdot M_T, \quad (1)$$

here a coefficient depends on the number of pins  $n$  uniformly spaced in any half-coupling (e.g.,  $a = 0,00909$  when  $n = 2$ ,  $a = 0,0245$  when  $n = 3$ ),  $M_T$  is a torque transmitted by the coupling;

- b) longitudinal strength of the pin is

$$N_{ar} = \frac{M_R}{2\pi R}, \quad (2)$$

here  $R$  is a radius of pins arrangement;

- c) a bending moment occurring due to the action of centrifugal forces of the ring [3] is:

$$M_{BL} = \left( \frac{1}{2\alpha} - \frac{1}{2\sin\alpha} - \frac{1}{2} \operatorname{tg} \frac{\alpha}{2} \right) \chi R, \quad (3)$$

here  $\alpha = \pi/n$

$$\chi = \frac{qR^2\omega^2}{A + \frac{FR^2}{I_x} B}, \quad (4)$$

$\chi$  radial reaction in the pins,  $q$  is the linear mass of the ring,  $\omega$  is the rate of coupling revolution,  $F$  is cross-section area of the rings,  $I_x$  is inertia moment of the ring cross-section with respect to the central axis perpendicular to the ring plane,  $A$  and  $B$  are coefficients dependent on  $n$  ( $A = 0,3926$ ,  $B = 0,0744$  when  $n = 2$ ;  $A = 0,4933$ ,  $B = 0,05708$  when  $n = 3$ );

- d) longitudinal strength of the ring due to the action of centrifugal forces is:

$$N_{LC} = qR^2\omega^2 - \frac{\chi}{2} \operatorname{ctg} \frac{\alpha}{2}. \quad (5)$$

The highest stresses in the ring occur at the point of its connection with the pins of the driving coupling therefore the condition of the ring strength is as follows:

$$\sigma = \frac{M_l + M_{BL}}{W_x} + \frac{N_{LC} - N_L}{F} \leq \sigma_{adm}, \quad (6)$$

where  $W_x$  is section modulus of the ring,  $\sigma_{adm}$  –

allowable bending stresses of the ring.

Torsional rigidity of the ring is:

$$C_R = b \frac{EI_x}{R}, \quad (7)$$

where  $b$   $n$ -is dependent coefficient ( $b = 52,9$  when  $n = 2$ ,  $b = 463$  when  $n = 3$ ),  $E$  is elasticity modulus of the ring material.

It is clear that to use the ring most efficiently providing minimum rigidity,  $M_T$  should slightly exceed the value at which the teeth engage. Following this, we will get the relationship for determining structural parameters of the ring:

$$\frac{\sigma_{adm} W_x R}{abEI_x} = k \frac{\pi}{z_f}, \quad (8)$$

where  $k$  is safety factor assumed to be equal to 1,2 – 1,5,  $z_f = d/m$ ,  $d$ ,  $m$  are pitch diameter and tooth engagement modulus the parameters of which are determined by well-known relationships taking into consideration the condition of maximum torque transmission.

To reduce axial coupling rigidity the ring is made of separate sheets. In the case when the mode is shifted by changing the conditions of ring deformation some additional supports preventing the extended parts of a flexible member to approach its revolution axis too closely are introduced in the coupling (Fig 2). The shape of the supports is made similar to that of the extended parts in order to enlarge the contact area with the ring. As a result a bending moment due to the action of the circular force is considerably reduced while the carrying capacity of a coupling is increased by an order or so because most of the flexible ring stresses are bending stresses caused by the above. When the contact is established the increasing circular force causes only tensile stresses.

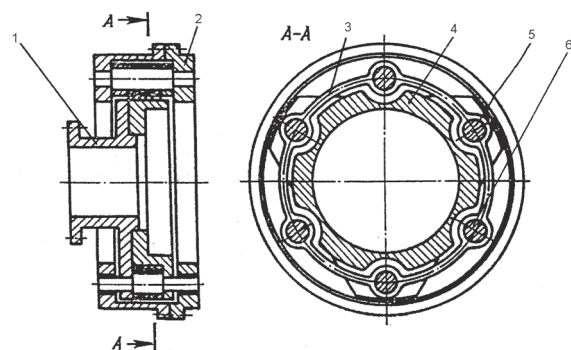

**Fig 2.** A schematic diagram of a coupling with additional supports: 1 – driving half-coupling, 2 – driven half-coupling, 3 – flexible ring, 4 – additional support, 5 – a pin connecting the ring with the driving half-coupling, 6 – a pin connecting the ring with the driven half-coupling

To determine the support profile the displacement of the driving half-coupling pins and radial displacement of the middle points of the stretched ring arcs should be found. The latter are calculated by a fictitious force method based on the curved rods theory implying that the deformation of only one sixth of the ring circumference under the action of the circular force  $T$  and radial force  $P$  applied to the middle of the arc is considered. The displacement in the direction of force  $P$  is expressed by:

$$\delta_P = \frac{E^3}{EI_x} (0,00699T - 0,0453P). \quad (9)$$

When  $P = 0$  we will get the displacement of the middle ring section when it comes in contact with the support (when changing to the second mode at the specified load). The same relationship can be used determining the approximate interacting force of the ring and the support because friction forces affecting the performance of a coupling in the second mode are created by it.

The analysis of operational conditions of a coupling has shown that if the arc bears against the support along its full length, the compensatory mechanisms are less effective while the ring load is increased. Therefore, the contact area making 0,3 – 0,5 of extended arc length can be considered the most appropriate. In coupling design radial arc section displacement can be assumed to be proportional to the section distance from the axis of the connecting pin, while restricting the profile of the middle support section to the circumference with the radius easily determined by simple geometric calculations.

When the coupling considered is used in high-speed drives the ring itself can increase disbalance because of the variation of its cross-section dimensions within the tolerances. The effect of ring deformation on centrifugal forces should be estimated. When the extended and compressed segments of one third of the ring length are individually considered, the following corrected values are obtained for centrifugal forces (Fig 3):

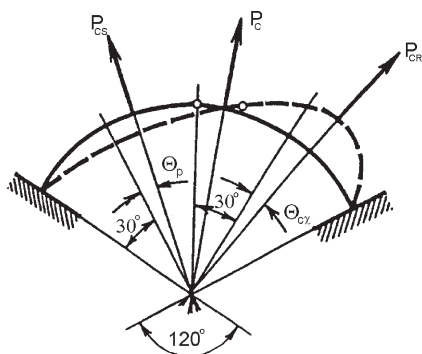

Fig 3. Centrifugal forces acting in the deformed portion of the ring

$$P_{CS} = 0,0929 \frac{\pi R^4 \rho F \omega^2 T}{EI_x}, \quad (10)$$

$$P_{CR} = 0,11689 \frac{\pi R^4 \rho F \omega^2 T}{EI_x}.$$

Calculations of the rotation rate and the ring length made with different applied loads have shown that various deviation angles of the loads resultant centrifugal forces from the middle of the respective arcs have a little effect, therefore the resultant of the centrifugal forces of one third of the ring can be obtained following the rule of vector summation of forces  $P_{ii}$  and  $P_{ign}$  and assuming the angle between them to be 120°. This means that

$$P_C = 0,1672 \frac{\pi R^4 \rho F \omega^2 T}{EI_x}. \quad (11)$$

### 3. A coupling with arched members

In this coupling (Fig 4) the driving and the driven half-couplings 1,2 are linked by flexible arc members 3 attached to half-couplings by pins 4,5. The pins of the connection are located in the depressions of half-couplings, therefore, when the angle of torsion exceeds a particular value, some of the arcs rest against the depression edge decreasing in length. As a result the rigidity of the coupling is increased. To reduce the load on a flexible member when torque is transmitted the radius of pins arrangement on the driving half-coupling should be larger than that of the driven half-coupling.

In Fig 5 a computational scheme of one flexible member is presented. Circular force  $T$  is acting tangentially to the circumference with radius  $R$ . The same reaction though in an opposite direction is observed

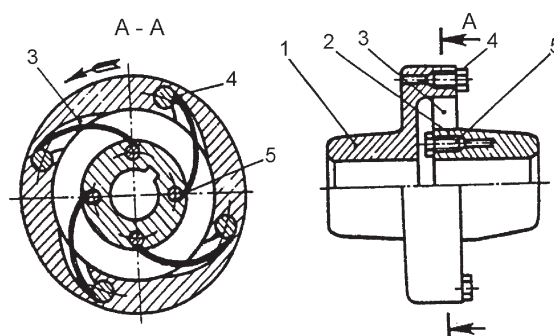

Fig 4. A diagram of a coupling with arched flexible members:

- 1 – driving half-coupling, 2 – driven half-coupling,
- 3 – arched flexible member, 4, 5 – a pins connecting arched flexible member with the driving half-coupling

in hinge *A* (i.e. at the connection point of the arc and the driven half-coupling). The following radial forces occur on hinges:

$$Q = T \frac{\sqrt{(2R_0 \sin \varphi/2)^2 - (r \sin \varphi)^2}}{r \sin \varphi} = T \cdot g \quad (12)$$

where *r* is radius of pins arrangement on the driven half-coupling, *R*<sub>0</sub> radius of curvature of flexible members. In Fig 6 the graphs illustrating the above relationship when *r* = 0.6*R*<sub>0</sub> are given. When the improper parameters are chosen some undesirable force *Q* can considerably exceed the circular force. The parametric values providing for the minimum *Q* value are the most appropriate.

The carrying capacity of a coupling is largely determined by the bending strength of a flexible member. The bending moment of the section, the position of which depends on angle *α* is expressed in the following way:

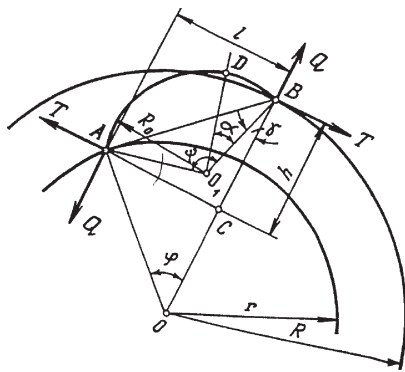

Fig 5. A design scheme of a flexible arched member

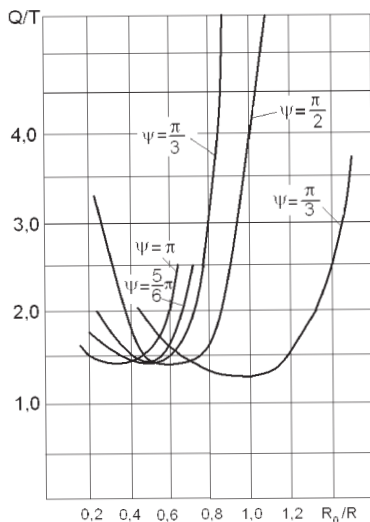

Fig. 6. The dependence of force relationship *Q*/*T* on the relationship between radii *R*<sub>0</sub>/*R*, when *r* = 0,6*R*

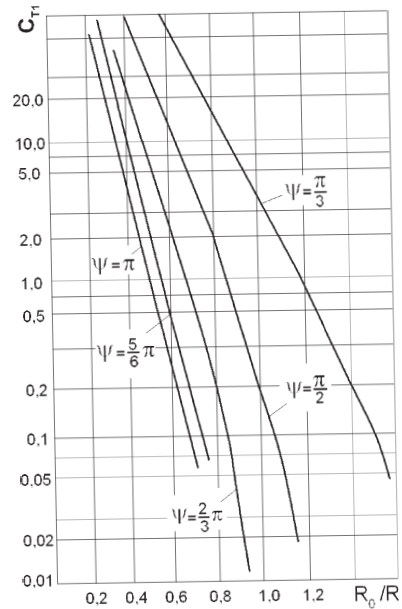

Fig 7. The dependence of torsional rigidity on the relationship between radii *R*<sub>0</sub>/*R*, when *r* = 0,6*R*. *C*<sub>*T*</sub> is expressed in terms of (*R*<sub>0</sub>/*R*)<sup>3</sup>/*K*

$$M_L = TR_0 \{ \cos \gamma (1 - \cos \alpha) - \sin \gamma \cdot \sin \alpha - g [ \sin \gamma (1 - \cos \alpha) + \cos \gamma \cdot \sin \alpha ] \}. \quad (13)$$

The analysis of the expression (13) has shown that given any coupling parameters *M*<sub>1</sub> assumes the largest value when *α* = *ψ*/2.

To determine torsional coupling rigidity the displacement in the direction of force *T* should be found:

$$\delta_T = \frac{\partial \Pi}{\partial T}, \quad (14)$$

where *Π* is the potential bending energy.

By using (14) the following expression can be obtained for torsional coupling rigidity:

$$c_s = \frac{sEI_x R^2}{R_0^3 K}, \quad (15)$$

where *s* is a number of flexible members in a coupling,

$$K = a \cdot \cos^2 \gamma - 2b \cdot \sin \gamma \cos \gamma + c \cdot \sin^2 \gamma - 2g [(a - c) \sin \gamma \cdot \cos \gamma + b (\cos^2 \gamma - \sin^2 \gamma)] + g^2 [a \cdot \cos^2 \gamma + 2b \cdot \sin \gamma \cdot \cos \gamma + c \cdot \cos^2 \gamma]$$

$$a = \frac{3}{2} \Psi - 2 \sin \Psi + \frac{1}{2} \sin 2\Psi,$$

$$b = 1 - \cos \Psi - \frac{1}{2} \sin \Psi,$$

$$c = \frac{1}{2}\Psi - \frac{1}{4}\Psi,$$

$g$  corresponds to formula (12).

In Fig 7 the graphs of the relationship (15) when  $r = 0,6R$  are shown.

The graphs given in Figs 6, 7 can be used choosing the approximate coupling parameters.

#### 4. Conclusions

1. The performance of vehicles can be considerably improved by replacing a commonly used flexible coupling by a coupling with the rigidity abruptly changing when transmitted torque is increased.

2. Rigidity and carrying capacity of couplings can be altered changing the conditions of ring deformation. This can be achieved by using some additional supports or engagement with a reduced number of teeth.

3. Compensational ability of couplings is improved when several arc members are used instead of the flexible ring member.

#### References

1. Kavlicoglu, B.; Gordaninejad, F.; Evrensel, C. A.; Cobanoglu, N.; Xin, M.; Heine, C., Fuchs, A., and Korol, G. A High-Torque Magneto-Rheological Fluid Clutch. In: Proceedings of SPIE Conference on Smart Materials and Structures, San Diego, March 2002.
2. Miyata, S.; Mashid, H. Development of the Half Toroidal CVT POWERTOROS Unit. *Motion & Control*, No 11 (October 2001), NSK.
3. Timoshenko, S. *Strength of Materials*. D. van Nostrand Company, Inc. Toronto, New York, London, 1987.