

Joint Source-Channel Coding with Correlated Interference

Yu-Chih Huang and Krishna R. Narayanan
 Department of Electrical and Computer Engineering
 Texas A&M University
 {jerry.yc.huang@gmail.com, krn@ece.tamu.edu}

Abstract

In this paper, we study the joint source-channel coding problem of transmitting a discrete-time analog source over an AWGN channel with interference known at transmitter. We consider the case when the source and the interference may not be uncorrelated. We first derive an outer bound on the achievable distortion and then, we propose two joint source-channel coding schemes to make use of the correlation between the source and the interference. The first scheme is the superposition of the uncoded signal and a digital part which is the concatenation of a Wyner-Ziv encoder and a dirty paper encoder. In the second scheme, the digital part is replaced by a hybrid digital and analog scheme so that the proposed scheme can provide graceful degradation in the presence of SNR mismatch. We then extend this coding scheme to the generalized cognitive radio channels and analyze the achievable distortion regions for several cases.

Index Terms

Distortion region, joint source-channel coding, cognitive radios.

I. INTRODUCTION AND PROBLEM STATEMENT

In this paper, we consider transmitting a length- n i.i.d. zero-mean Gaussian source $V^n = (V(1), V(2), \dots, V(n))$ over n uses of an AWGN channel with noise $Z^n \sim \mathcal{N}(0, N \cdot I)$ in the presence of Gaussian interference S^n which is known at the transmitter as shown in Fig. 1. Throughout the paper, we only focus on the bandwidth-matched case, i.e., the number of channel uses is equal to the source's length. The transmitted signal $X^n = (X(1), X(2), \dots, X(n))$ is subject to a power constraint

$$\frac{1}{n} \sum_{i=1}^n \mathbb{E}[X(i)^2] \leq P, \quad (1)$$

where $\mathbb{E}[\cdot]$ represents the expectation operation. The received signal Y^n is given by

$$Y^n = X^n + S^n + Z^n. \quad (2)$$

We are interested in the expected distortion between the source and the estimate \hat{V}^n at the output of the decoder given by

$$d = \mathbb{E}[d(V^n, g(f(V^n, S^n) + S^n + Z^n))], \quad (3)$$

where f and g are a pair of source-channel coding encoder and decoder, respectively, and $d(\cdot, \cdot)$ is the mean squared error distortion measure given by

$$d(v^n, \hat{v}^n) = \frac{1}{n} \sum_{i=1}^n (v(i) - \hat{v}(i))^2. \quad (4)$$

Here the lower case letters represent realizations of random variables denoted by upper case letters. As in [1], a distortion D is achievable under power constraint P if for any $\varepsilon > 0$ and sufficiently large n , there exists a source-channel code such that $d \leq D + \varepsilon$.

When V and S are uncorrelated, it is known that an optimal quantizer followed by a Costa's dirty paper coding (DPC) [2] is optimal and the corresponding joint source-channel coding problem is fully discussed in [3]. However, different from the

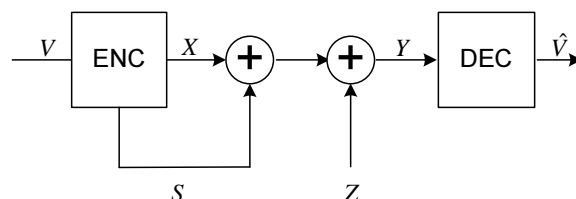

Fig. 1. Joint source-channel coding with interference known at transmitter.

typical writing on dirty paper problem, in this paper, we consider the case that the source and the interference may not be uncorrelated to each other. The covariance matrix is described as follows,

$$\Lambda_{VS} = \begin{pmatrix} \sigma_1^2 & \rho\sigma_1\sigma_2 \\ \rho\sigma_1\sigma_2 & \sigma_2^2 \end{pmatrix} \quad (5)$$

and ρ may not be 0.

Under this assumption separate source and channel coding using DPC naively may not be a good candidate for encoding V^n in general. It is due to the fact that the DPC tries to completely avoid the interference without signal to noise ratio (SNR) penalty so that it cannot take advantage of the correlation between the source and the interference. In this paper, we first derive an outer bound on the achievable distortion region and then, we propose two joint source-channel coding schemes which exploit the correlation between V^n and S^n thereby outperforming the naive DPC scheme. The first scheme is a superposition of the uncoded scheme and a digital part formed by a Wyner-Ziv coding [4] followed by a DPC, which we refer to as a separation-based scheme. The second scheme is obtained by replacing the digital part by a hybrid digital and analog (HDA) scheme given in [3] that has been shown to provide graceful degradation under an SNR mismatch. We then analyze the performance of these two proposed schemes for SNR mismatch cases. It is shown that both the HDA scheme and the separation-based digital scheme benefit from a higher SNR; however, interestingly, their performances are different.

One interesting application of this problem is to derive the achievable distortion region for the generalized cognitive radio channels considered in [5] (also in [6]). This channel can be modeled as a typical two-user interference channel except that one of them knows exactly what the other plans to transmit. We can regard the informed user's channel as the setup we consider in this section and then analyze achievable distortion regions for several different cases.

The rest of the paper is organized as follows. In section II, we present some prior works which are closely related to ours. The outer bound is given in section III and two proposed schemes are given in section IV. In section V, we analyze the performance of the proposed schemes under SNR mismatch. These proposed schemes are then extended to the generalized cognitive radio channels in section VI. Some conclusions are given in VII.

II. RELATED WORKS ON JSCC WITH INTERFERENCE KNOWN AT TRANSMITTER

In [7], Lapidoth *et al.* consider the 2×1 multiple access channel in which two transmitters wish to communicate their sources, which are drawn from a bi-variate Gaussian distribution, to a receiver which is interested in reconstructing both sources. This setup looks somewhat similar to ours if the receiver is only interested in one part of the sources. However, an important difference in their setup is that the transmitters are not allowed to cooperate with each other, i.e., for the particular transmitter, the interference is not known.

In [8], Tian *et al.* consider transmitting a bi-variate Gaussian source over 1×2 Gaussian Broadcast Channel. In their setup, the source consisting of two components V_1^n and V_2^n memoryless and stationary bi-variate Gaussian distributed and each receiver is only interested in one part of the sources. They proposed a HDA scheme which performs optimally in terms of distortion region under all SNRs. At first glance, this problem is again similar to ours if we ignore receiver 2 and focus on the other. Then this problem reduces to communicating V_1^n with correlated side-information V_2^n given at the transmitter. A crucial difference is that this side-information does not appear in the received signal. Therefore, the side-information is completely useless.

Joint source-channel coding for point to point communications over Gaussian channels has been widely discussed. e.g. [3], [9], [10]. However, they either don't consider interference ([9], [10]) or assume independence of source and interference ([3]). In [3], Wilson *et al.* proposed a HDA coding scheme for the typical writing on dirty paper problem in which the source is independent to the interference. This HDA scheme is originally proposed to perform well in the case of a SNR mismatch. In [3], the authors showed that their HDA scheme not only achieves the optimal distortion in the absence of SNR mismatch but also provides gracefully degradation in the presence of SNR mismatch. In the following section, we will discuss this scheme in detail and then propose a coding scheme based on this one.

From now on, since all the random variables we consider are i.i.d. in time, i.e. $V(i)$ is independent of $V(j)$ for $i \neq j$, we will drop the index i for the sake of convenience.

III. OUTER BOUNDS

A. Outer Bound 1

For comparison, we first present a genie-aided outer bound. This outer bound is derived in a similar way to the one in [11] in which we assume that S is revealed to the decoder by a genie. Thus, we have

$$\begin{aligned} \frac{1}{2} \log \frac{\sigma_1^2(1-\rho^2)}{D_{ob}} &\stackrel{(a)}{\leq} I(V; \hat{V}|S) \\ &\stackrel{(b)}{\leq} I(V; Y|S) \\ &= h(Y|S) - h(Y|S, V) \end{aligned}$$

$$\begin{aligned}
&= h(X + Z|S) - h(Z) \\
&\stackrel{(c)}{\leq} h(X + Z) - h(Z) \\
&\stackrel{(d)}{\leq} \frac{1}{2} \log \left(1 + \frac{P}{N} \right), \tag{6}
\end{aligned}$$

where (a) follows from the rate-distortion theory [1], (b) is from the data processing inequality, (c) is due from that conditioning reduces differential entropy and (d) comes from the fact that Gaussian density maximizes the differential entropy. Therefore, we have the outer bound as

$$D_{ob,1} = \frac{\sigma_1^2(1 - \rho^2)}{1 + P/N}. \tag{7}$$

Note that this outer bound is in general not tight for our setup since in the presence of correlation, giving S to the decoder also offers a correlated version of the source that we wish to estimate. For example, in the case of $\rho = 1$, giving S to the decoder implies that the outer bound is $D_{ob} = 0$ no matter what the received signal Y is. On the other hand, if $\rho = 0$, the setup reduces to the one with uncorrelated interference and we know that this outer bound is tight. Now, we present another outer bound that improves this outer bound for some values of ρ .

B. Outer Bound 2

Since S and V are drawn from a jointly Gaussian distribution with covariance matrix given in (5), we can write

$$S = \rho \frac{\sigma_2}{\sigma_1} V + N_\rho, \tag{8}$$

where $N_\rho \sim \mathcal{N}(0, (1 - \rho^2)\sigma_2^2)$ and is independent to V . Now, suppose a genie reveals only N_ρ to the decoder, we have

$$\begin{aligned}
\frac{1}{2} \log \frac{\sigma_1^2}{D_{ob,2}} &= \frac{1}{2} \log \frac{\text{var}(V|N_\rho)}{D_{ob}} \\
&\stackrel{(a)}{\leq} I(V; \hat{V}|N_\rho) \\
&\stackrel{(b)}{\leq} I(V; Y|N_\rho) \\
&= h(Y|N_\rho) - h(Y|N_\rho, V) \\
&= h(X + \rho \frac{\sigma_2}{\sigma_1} V + Z|N_\rho) - h(Z) \\
&\stackrel{(c)}{\leq} h(X + \rho \frac{\sigma_2}{\sigma_1} V + Z) - h(Z) \\
&\stackrel{(d)}{\leq} \frac{1}{2} \log \left(\frac{\text{var} \left(X + \rho \frac{\sigma_2}{\sigma_1} V \right)}{N} \right) \\
&\stackrel{(e)}{\leq} \frac{1}{2} \log \left(1 + \frac{(\sqrt{P} + \rho \sqrt{\sigma_2^2})^2}{N} \right), \tag{9}
\end{aligned}$$

where (a)-(d) follows from the same reasons with those in the previous outer bound and (e) is due from that the maximum occurs when we let X to be a scaled version of V . Thus, we have

$$D_{ob,2} = \frac{\sigma_1^2}{1 + (\sqrt{P} + \rho \sqrt{\sigma_2^2})^2 / N}. \tag{10}$$

Note that although the encoder knows the interference S exactly instead of just N_ρ , the outer bound is valid since S is a function of V and N_ρ .

Remark 1: If $\rho = 0$, this outer bound reduces to the previous one and is tight. If $\rho = 1$, the genie actually reveals nothing to the decoder and the setup reduces to the one considered in [12] that the encoder is interested in revealing the interference to the decoder. For this case, we know that this outer bound is tight. However, this outer bound is in general optimistic except for two extremes. It is due to the fact that in derivations, we assume that we can simultaneously ignore the N_ρ and use all the power to take advantage of the coherent part. Despite this, the outer bound still provides an insight into building a good coding scheme that one should try to use a portion of power to make use of the correlation and then use the remaining power to avoid N_ρ .

Further, it is natural to come up with an outer bound which is the maximum of the above two as

$$D_{ob} = \max\{D_{ob,1}, D_{ob,2}\}. \tag{11}$$

IV. PROPOSED SCHEMES

A. Uncoded Scheme

We first analyze the distortion of the uncoded scheme where the transmitted signal is simply the scaled version of the source

$$X = \sqrt{\frac{P}{\sigma_1^2}} V. \quad (12)$$

Thus, (2) becomes

$$Y = \sqrt{\frac{P}{\sigma_1^2}} V + S + Z. \quad (13)$$

The receiver forms the linear MMSE estimate of V from Y as $\hat{V} = \beta Y$, where

$$\beta = \frac{\sigma_1^2(\sqrt{P/\sigma_1^2} + \rho\sigma_2/\sigma_1)}{P + \sigma_2^2 + N + 2\sqrt{P/\sigma_1^2}\rho\sigma_1\sigma_2}. \quad (14)$$

The corresponding distortion is then given as

$$D_{unc} = \sigma_1^2 \left(1 - \beta \left(\sqrt{\frac{P}{\sigma_1^2}} + \rho \frac{\sigma_2}{\sigma_1} \right) \right). \quad (15)$$

Remark 2: If $\rho = 1$ and $\sigma_1^2 = \sigma_2^2$, the source and the interference are exactly the same and the problem reduces to transmitting V over an AWGN channel Z with power constraint $(\sqrt{P} + \sqrt{\sigma_1^2})^2$. From [13] [14], we know that the uncoded scheme is optimal for this case. One can also think of this scenario as that the transmitter is only interested in revealing the channel state S to the receiver. In [12], the authors have shown that the pure amplification (uncoded) scheme is optimal for this problem. Therefore, we can expect that the uncoded scheme will eventually achieve the optimal distortion when $\rho = 1$.

B. Naive DPC Scheme

Another existing scheme is the concatenation of an optimal source code and a DPC. The optimal source code quantizes the analog source with a rate arbitrarily close to the channel capacity $1/2 \log(1 + P/N)$. Then, the DPC ignores the correlation between the source and interference (this can be done by a randomization and de-randomization pair) and encodes the quantization output accordingly. Since the DPC achieves the rate equal to that when there is no interference at all, the receiver can correctly decode these digital bits with high probability. By the rate-distortion theory, we have the corresponding distortion as

$$D_{DPC} = \frac{\sigma_1^2}{1 + P/N}. \quad (16)$$

Remark 3: In the absence of correlation, i.e., $\rho = 0$, the problem reduces to the typical writing on dirty paper setup and it is known that this scheme is optimal but the uncoded scheme is strictly suboptimal. Therefore, we can expect that when the correlation is small, this naive DPC scheme will outperform the uncoded scheme.

C. Separation-Based Scheme

We now propose a separation-based scheme which retains the advantages of the above two schemes. This scheme can be regarded as an extended version of the coding scheme in [10] to the setup we consider. As shown in Fig. 2, the transmitted signal of this scheme is the superposition of the analog part X_a with power P_a and the digital part X_d with power $P - P_a$. The motivation here is to allocate larger power for the analog part to make use of the interference which is somewhat coherent to the source for large ρ 's and to assign more power to the digital part to avoid the interference when ρ is small. The analog part is the scaled version of linear combination of source and interference as

$$X_a = \sqrt{a}(\gamma V + (1 - \gamma)S), \quad (17)$$

where $P_a \in [0, P]$, $a = P_a/\sigma_a^2$, $\gamma \in [0, 1]$ and

$$\sigma_a^2 = \gamma^2\sigma_1^2 + (1 - \gamma)^2\sigma_2^2 + 2\gamma(1 - \gamma)\rho\sigma_1\sigma_2. \quad (18)$$

The received signal is given by

$$\begin{aligned} Y &= X_d + X_a + S + Z \\ &= X_d + \sqrt{a}(\gamma V + (1 - \gamma)S) + S + Z \\ &= X_d + \sqrt{a}\gamma V + (1 + \sqrt{a}(1 - \gamma))S + Z \\ &= X_d + S' + Z, \end{aligned} \quad (19)$$

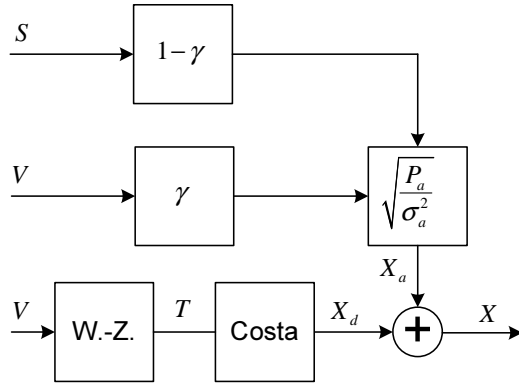

Fig. 2. Separation-based scheme.

where X_d is chosen to be orthogonal to S and V . The receiver first makes an estimate from Y only as $V' = \beta Y$ with

$$\beta = \frac{\sqrt{a}(\gamma\sigma_1^2 + (1-\gamma)\rho\sigma_1\sigma_2) + \rho\sigma_1\sigma_2}{P + N + \sigma_2^2 + 2\sqrt{a}((1-\gamma)\sigma_2^2 + \gamma\rho\sigma_1\sigma_2)}. \quad (20)$$

The corresponding MSE is

$$D^* = \sigma_1^2 \left[1 - \beta \left(\sqrt{a}(\gamma + (1-\gamma)\rho\frac{\sigma_2}{\sigma_1}) + \rho\frac{\sigma_2}{\sigma_1} \right) \right]. \quad (21)$$

Thus, we can write $V = V' + W$ with $W \sim \mathcal{N}(0, D^*)$.

We now refine the estimate through the digital part, which is the concatenation of a Wyner-Ziv coding and a DPC. Since the DPC achieves the rate equal to that when there is no interference at all, the encoder can use the remaining power $P - P_a$ to reliably transmit the refining bits T with a rate arbitrarily close to

$$R = \frac{1}{2} \log \left(1 + \frac{P - P_a}{N} \right). \quad (22)$$

The resulting distortion after refinement is then given as

$$D_{sep} = \inf_{\gamma, P_a} \frac{D^*}{1 + \frac{P - P_a}{N}}. \quad (23)$$

In Appendix A, for self-containedness, we briefly summarize the digital Wyner-Ziv scheme to illustrate how to achieve the above distortion.

It is worth noting that setting $\gamma = 1$ gives us the lowest distortion always. i.e., super-imposing S onto the transmitted signal is completely unnecessary. However, it is in general not true for the cognitive radio setup. We will discuss this in detail in section VI.

Remark 4: Different from the setup considered by [10] that the optimal distortion can be achieved by any power allocation between coded and uncoded transmissions, in our setup the optimal distortion is in general achieved by a particular power allocation which is a function of ρ . For example, in the absence of correlation, i.e., S is completely independent to V , one can simply set $P_a = 0$ and this scheme reduces to the naive DPC which is optimal in this case. On the other hand, if $\rho = 1$, the optimal distortion is achieved by setting $P_a = P$. Moreover, for $\rho > 0$, it is beneficial to have a non-zero P_a making use of the correlation between the source and the interference.

Remark 5: Although this scheme contains the pure analog signals in part, we refer to this scheme as separation-based scheme in order to distinguish it from the HDA scheme introduced in the following. However, one should realize that this scheme is different from the typical separation-based scheme.

D. HDA Scheme

Now, let us focus on the HDA scheme shown in Fig. 3 in which we replace the digital part by the HDA scheme given in [3]. The analog signal remains the same as (17) and the HDA output is referred to as X_h . Therefore, we have

$$\begin{aligned} Y &= X_h + \sqrt{a}\gamma V + (1 + \sqrt{a}(1-\gamma))S + Z \\ &= X_h + S' + Z. \end{aligned} \quad (24)$$

Again, the HDA scheme regards S' as interference and V' described previously as side-information. The encoding and decoding procedures are listed below and the coefficients are re-derived to fit our setup (the reader is referred to [3] for details).

Let the auxiliary random variable U be

$$U = X_h + \alpha S' + \kappa V, \quad (25)$$

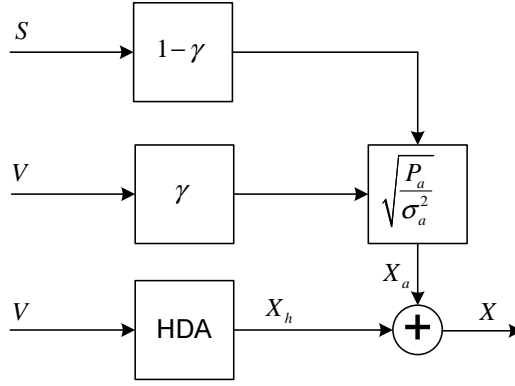

Fig. 3. HDA scheme.

where $X_h \sim \mathcal{N}(0, P)$ independent to S' and V and the covariance matrix of S' and V can be computed by (5).

Codebook Generation: Generate a random i.i.d. codebook \mathcal{U} with 2^{nR_1} codewords, reveal this codebook to both transmitter and receiver.

Encoding: Given an S' and V , find a U which is jointly typical with (S', V) . If such an U can be found, transmit $X_h = U - \alpha S' - \kappa V$. Otherwise, an encoding failure is declared.

Decoding: The decoder looks for a U which is jointly typical with the received signal Y and V' . A decoding failure is declared if none or more than one such U are found.

Estimation: After decoding U , the receiver forms a linear MMSE estimate of V from Y and U . The distortion is then obtained as

$$D_{hda} = \inf_{\gamma, P_a} [\sigma_1^2 - \Gamma^T \Lambda_{UY}^{-1} \Gamma], \quad (26)$$

where Λ_{UY} is the covariance matrix of U and Y , and

$$\Gamma = [\mathbb{E}[VU], \mathbb{E}[VY]]^T. \quad (27)$$

In the encoding step, to make sure the probability of encoding failure vanishes with increasing n , we require

$$\begin{aligned} R_1 &> I(U; S', V) \\ &= h(U) - h(U|S', V) \\ &= h(U) - h(X_h + \alpha S' + \kappa V|S', V) \\ &\stackrel{(a)}{=} h(U) - h(X_h) \\ &= \frac{1}{2} \log \frac{\mathbb{E}[U^2]}{P_h}. \end{aligned} \quad (28)$$

where (a) follows because X_h is independent of S' and V .

Further, to guarantee the decodability of U in the decoding step, one requires

$$\begin{aligned} R_1 &< I(U; Y, V') \\ &= h(U) - h(U|Y, V') \\ &= h(U) - h(U - \alpha Y - \kappa V'|Y, V') \\ &\stackrel{(a)}{=} h(U) - h(\kappa W + (1 - \alpha)X_h - \alpha Z|Y), \end{aligned} \quad (29)$$

where (a) follows from $V' = \beta Y$. By choosing

$$\alpha = \frac{P_h}{P_h + N} \quad (30)$$

and

$$\kappa^2 = \frac{P_h^2}{(P_h + N)D^*}, \quad (31)$$

one can verify that (28) and (29) are satisfied. Note that in (28) what we really need is $R_1 \geq I(U; S', V) + \varepsilon$ and in (29) it is $R_1 \leq I(U; Y, V') - \delta$. However, since ε and δ can be made arbitrarily small, these are omitted for the sake of convenience and to maintain clarity.

Remark 6: It can be verified that the distortions in (23) and (26) are exactly the same. However, it has been shown in [3] that the HDA scheme can provide graceful degradation in the SNR mismatch case.

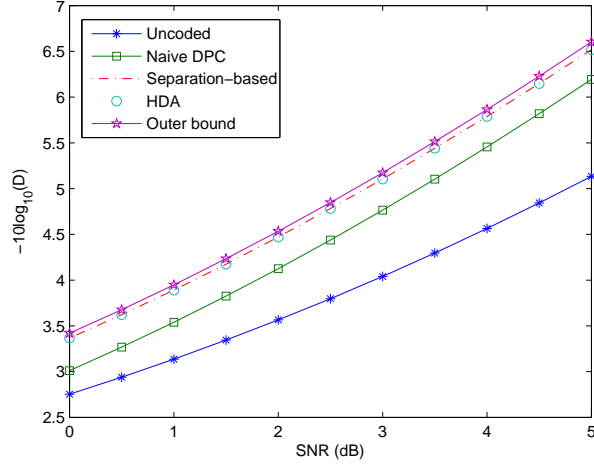

Fig. 4. $\frac{P}{N}$ vs D , $\rho = 0.3$.

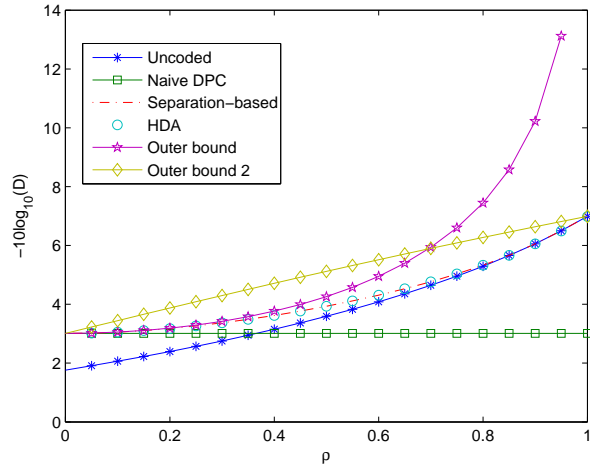

Fig. 5. ρ vs D with $\sigma_1 = \sigma_2 = 1$ and $\frac{P}{N} = 1$.

E. Numerical Results

Here, we compare the outer bounds and achievable distortions of schemes previously discussed. In Fig. 4, we compare the distortions (in $-10\log_{10}(D)$) for different SNRs. In this figure, we set $\sigma_1^2 = \sigma_2^2 = 1$ and the correlation is $\rho = 0.3$. As we expected, two proposed schemes have exactly the same performance. Moreover, for this case, these two schemes not only outperform others but also approach the outer bound (maximum of two) very well.

We then compare the distortions for a fixed SNR but different ρ in Fig. 5. The parameters are set to be $\sigma_1^2 = \sigma_2^2 = 1$ and $P/N = 1$. It can be seen that the proposed schemes outperform the naive DPC scheme and the uncoded scheme and performs close to the outer bound over a wide range of ρ 's. The outer bound and the inner bound do not coincide however, leaving room for improvement either of the outer bound or the schemes. As we discussed in *Remark 2* and *Remark 3*, the naive DPC scheme performs optimally when $\rho = 0$ and performs better than the uncoded scheme at small ρ regime. However, the uncoded scheme outperforms the naive DPC scheme at large ρ regime and eventually achieves optimum when $\rho = 1$. Further, the separation-based scheme and the HDA scheme achieve optimal distortion at both $\rho = 0$ and $\rho = 1$ and clearly outperform others for $\rho \in (0, 1)$.

V. PERFORMANCE ANALYSIS IN THE PRESENCE OF SNR MISMATCH

In this section, we study the distortions for the proposed schemes in the presence of SNR mismatch i.e., we consider the scenario where instead of knowing the exact channel SNR, the transmitter only knows a lower bound of channel SNR. Specifically, we assume that the actual channel noise to be $Z_a \sim \mathcal{N}(0, N_a)$ but the transmitter only knows that $N_a \leq N$ so that it designs the coefficients for this N . Different from typical separation-based schemes, the proposed separation-based

scheme may be able to take advantage of SNR mismatch although it quantizes the source explicitly. It is due to the fact that the proposed separation-based scheme contains the pure source in part. Furthermore, for the HDA scheme, the ability of combating SNR mismatch has been discussed in [3]. Therefore, we expect that both two schemes will benefit from a better SNR they experience.

A. Separation-Based Scheme

Since the transmitter designs its coefficients for N , it aims to achieve the distortion D_{sep} given in (23). It first quantizes the source to T by a Wyner-Ziv coding with side-information D^* given in (21) and then encodes the quantization output by a DPC with a rate

$$R = \frac{1}{2} \log \left(1 + \frac{P - \tilde{P}_a}{N} \right), \quad (32)$$

where \tilde{P}_a is the power allotted to X_a such that the distortion in the absence of SNR mismatch is minimized. i.e.,

$$\tilde{P}_a = \arg \inf_{P_a} \frac{D^*}{1 + \frac{P - P_a}{N}}. \quad (33)$$

At receiver, since $N_a \leq N$, the DPC decoder can correctly decode T with high probability. Moreover, the receiver forms the MMSE of V from Y as $V'_a = \beta_a Y$ with

$$\beta_a = \frac{\sqrt{a}(\gamma\sigma_1^2 + (1 - \gamma)\rho\sigma_1\sigma_2) + \rho\sigma_1\sigma_2}{P + N_a + \sigma_2^2 + 2\sqrt{a}((1 - \gamma)\sigma_2^2 + \gamma\rho\sigma_1\sigma_2)}, \quad (34)$$

$$D_a^* = \sigma_1^2 \left[1 - \beta_a \left(\sqrt{a}(\gamma + (1 - \gamma)\rho\frac{\sigma_2}{\sigma_1}) + \rho\frac{\sigma_2}{\sigma_1} \right) \right]. \quad (35)$$

Thus, the problem reduces to the Wyner-Ziv problem with mismatch side-information. In Appendix B, we show that for this problem, one can achieve

$$D_{sep, mis} = \frac{D^* D_a^*}{D^* D_a^* + (D^* - D_a^*) D_{sep}} D_{sep}. \quad (36)$$

Different from typical separation-based schemes that we have seen in [3], the proposed separation-based scheme can still take advantage of better channels through mismatched side-information. i.e., this scheme does not suffer from the pronounced "threshold effect".

B. HDA Scheme

Although it is shown in Appendix B that the performance of the HDA scheme is exactly the same with the digital Wyner-Ziv scheme under side-information mismatch, this problem with HDA scheme cannot be reduced to the Wyner-Ziv problem with mismatch side-information as we did for the separation-based scheme. It is due from that the HDA scheme still makes an estimate of V from U which is a function of S . Fortunately, as shown in [3], the HDA scheme is capable of making use of SNR mismatch.

Similar to the separation-based scheme, we design the coefficients for channel parameter N . The HDA scheme regards D^* as side-information and S' as interference. It generates the auxiliary random variable U given by (25) with coefficients described by (30) and (31). Since $N_a \leq N$, the receiver can correctly decode U with high probability. The receiver then forms the MMSE as described in (26) and (27). Note that $\mathbb{E}[Y^2]$ in Λ_{UY} should be modified appropriately to address the fact that the actual noise variance is N_a in this case.

Remark 7: In [12], the optimal tradeoff between the achievable rate and the error in estimating the interference at the designed SNR is studied. In [3], the authors also studied a somewhat similar problem. They compare the distortions of the digital scheme and the HDA scheme in estimating the source V and the interference S as we move away from the designed SNR. One important observation is that the HDA scheme outperforms the digital scheme in estimating the source; however, the digital scheme is better than the HDA scheme if one is interested in estimating the interference. Here, since the *effective* interference S' includes the uncoded signal $\sqrt{a}V$ in part and the source is assumed to be correlated to the interference, estimating the source V is equivalent to estimating a part of S' . Thus, one can expect that if the P_a we choose and the correlation ρ are large enough, the benefit coming from using the HDA scheme to estimate the source may be less than that from adopting the separation-based scheme to estimate a part of S' . Consequently, for a sufficiently large P_a and ρ , the separation-based scheme may be better than the HDA scheme in the presence of SNR mismatch.

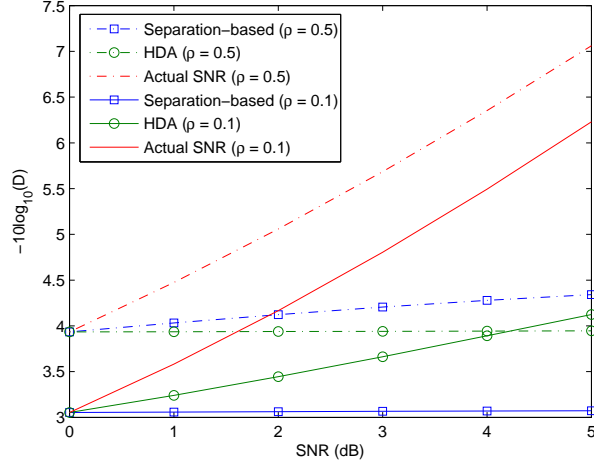

Fig. 6. SNR mismatch case for small designed SNR.

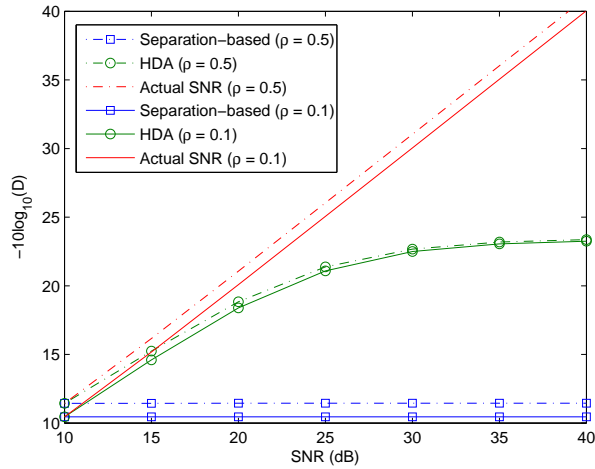

Fig. 7. SNR mismatch case for large designed SNR.

C. Numerical Results

Now, we compare the performance of the above two schemes and the scheme that knows the actual SNR. The parameters are set to be $\sigma_1^2 = \sigma_2^2 = 1$. We plot the $-10 \log_{10}(D)$ as we move away from the designed SNR for both small ($\rho = 0.1$) and large ($\rho = 0.5$) correlations. Two examples for designed SNR = 0 dB and 10 dB are given in Fig. 6 and Fig. 7, respectively.

In Fig. 6, we consider the case that the designed SNR is 0 dB which is relatively small compared to the variance of interference. For this case, we can see that which scheme performs better in the presence of SNR mismatch really depends on ρ . It can be explained by the observations made in *Remark 7* and the power allocation strategy. For this case the optimal power allocation \tilde{P}_a is proportional to ρ . For $\rho = 0.1$ case, since the correlation is small and the assigned \tilde{P}_a is also small, the HDA scheme is better than the separation-based scheme. On the other hand, for $\rho = 0.5$ case, we allot a relatively large power to \tilde{P}_a so that one may get a better estimate if we try to use the separation-based scheme to estimate a part of S' . This property is further discussed in the Appendix C.

In Fig. 7, we design the coefficients for SNR = 10 dB which can be regarded as relatively large SNR compared to the variance of interference. For this case, the optimal power allocation \tilde{P}_a for both $\rho = 0.1$ and $\rho = 0.5$ are relatively small. Therefore, the performance improvement provided by the HDA scheme is larger than that provided by the separation-based scheme for both cases.

VI. JSCC FOR GENERALIZED COGNITIVE RADIO CHANNELS

There has been a lot of interest in cognitive radio since it has been proposed in [15] for flexible communication devices and higher spectral efficiency. In a conventional cognitive radio setup, the lower priority user (usually referred to as secondary

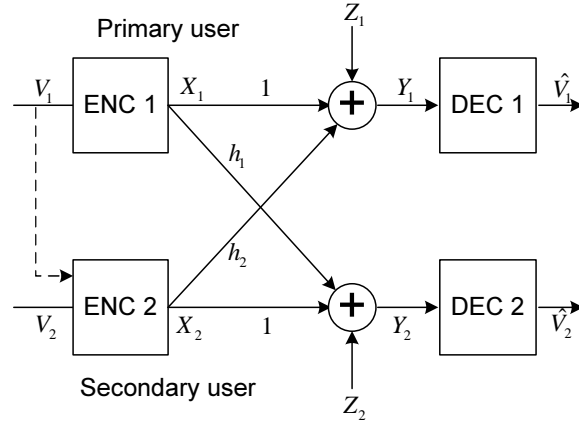

Fig. 8. Setup of cognitive radio channels.

user) listens to the wireless channel and transmits the signal only through the spectrum not used by the higher priority user (referred to as primary user).

In [5], Devroye *et al.* define the generalized cognitive radio channels in which simultaneous transmission over the same time or frequency is allowed. This channel can be modeled as a typical two-user interference channel except that one of users knows exactly what the other plans to transmit. The authors then provide inner and outer bounds on how much rate two users can transmit simultaneously for such generalized cognitive radio channel. Their achievable scheme is based on the DPC and the Han-Kobayashi scheme [16].

In this section, we consider the same generalized cognitive radio channels as in [5] and focus on the case when both two users have analog information. We are interested in the distortion region which describes how much distortion two users can achieve simultaneously. In particular, we consider the case that two sources may not be uncorrelated to each other. As we mentioned before, we first look at the distortion of the secondary user only and regard it as the setup in section II. An achievable distortion region is obtained by forcing the primary user to use the uncoded scheme and using the HDA given in section IV for the secondary user. It can be shown that when the correlation is large, adopting the proposed scheme at the secondary user not only takes advantage of this correlation but also benefits the primary user. On the other hand, when ρ is small, the proposed scheme helps the secondary user to avoid the interference introduced by the primary user.

As shown in Fig. 8, in a generalized cognitive radio channel, two users wish to transmit their own sources V_1 and V_2 to the corresponding receiver through an interference channel with direct channel gain 1 and cross channels h_1 and h_2 representing the real-valued channel gains from user 1 to user 2 and vice versa, respectively. The power constraints imposed on the outputs of user 1 and 2 are P_1 and P_2 , respectively. Different from interference channels, in cognitive radio channels, we assume that the secondary user knows V_1 non-causally. Here, we also assume that the channel coefficient h_1 is known by the secondary user. The received signals are

$$\begin{pmatrix} Y_1 \\ Y_2 \end{pmatrix} = \begin{pmatrix} 1 & h_1 \\ h_2 & 1 \end{pmatrix} \begin{pmatrix} X_1 \\ X_2 \end{pmatrix} + \begin{pmatrix} Z_1 \\ Z_2 \end{pmatrix}. \quad (37)$$

Further, we consider the case that two sources may have correlation with each other. The covariance matrix is then given as

$$\Lambda_{V_1 V_2} = \begin{pmatrix} \sigma_{V_1}^2 & \rho \sigma_{V_1} \sigma_{V_2} \\ \rho \sigma_{V_1} \sigma_{V_2} & \sigma_{V_2}^2 \end{pmatrix}. \quad (38)$$

We now apply the proposed HDA scheme to this scenario. Let the primary user simply transmit the scaled version of the uncoded source

$$X_1 = \sqrt{\frac{P_1}{\sigma_{V_1}^2}} V_1. \quad (39)$$

Therefore, the bottom channel in Fig. 8 reduces to the situation we considered in the previous section with source $V = V_2$ and interference $S = h_1 X_1$. The covariance matrix becomes (5) with

$$\sigma_1^2 = \sigma_{V_2}^2, \quad (40)$$

$$\sigma_2^2 = h_1^2 P_1. \quad (41)$$

The secondary user then encodes its source to X_2 by the HDA scheme described previously in section IV-D with power P_2 and coefficients according to (30) and (31). With these coefficients, the corresponding distortion D_2 is computed by (26) and

(27). At the receiver 1, the received signal is

$$\begin{aligned} Y_1 &= X_1 + h_2 X_2 + Z_1 \\ &= (1 + (1 - \gamma)\sqrt{a}h_1h_2) X_1 + h_2 X_h + h_2\sqrt{a}\gamma V_2 + Z_1. \end{aligned} \quad (42)$$

The decoder 1 then forms a linear MMSE estimate from Y_1 given by $\hat{V}_1 = \beta Y_1$, where

$$\beta = \frac{\mathbb{E}[V_1 Y_1]}{\mathbb{E}[Y_1^2]} \quad (43)$$

with

$$\mathbb{E}[V_1 Y_1] = (1 + (1 - \gamma)\sqrt{a}h_1h_2) \sqrt{P_1 \sigma_{V_1}^2} + h_2 \sqrt{a} \gamma \rho \sigma_{V_1} \sigma_{V_2} \quad (44)$$

$$\begin{aligned} \mathbb{E}[Y_1^2] &= (1 + (1 - \gamma)\sqrt{a}h_1h_2)^2 P_1 + ah_2^2 \gamma^2 \sigma_{V_2}^2 + \\ &h_2^2 P_h + 2\sqrt{a}h_2 \gamma \rho \sqrt{P_1 \sigma_{V_2}^2} (1 + (1 - \gamma)\sqrt{a}h_1h_2). \end{aligned} \quad (45)$$

Therefore, the corresponding distortion is

$$D_1 = \sigma_{V_1}^2 - \beta \mathbb{E}[V_1 Y_1] \quad (46)$$

It can be shown that assigning $\gamma = 1$ leads to a suboptimal D_1 in general. Thus, as we mentioned before, one may want to assign non-zero power to transmit S in order to achieve a larger distortion region.

We can then optimize the power allocation for particular performance criteria. For instance, if one desires achieving the minimum distortion for the secondary user, γ should be set to be 1. However, if the target is to obtain the largest achievable distortion region under a total power constraint P , one should optimize over $P_1 \in [0, P]$, $P_a \in [0, 1 - P_1]$, and $\gamma \in [0, 1]$. We briefly discuss these examples below.

1. Greedy Case: We first consider the greedy case where the secondary user focus on reducing its own distortion. As we mentioned before, the proposed scheme should always set $\gamma = 1$ for this case. For comparison, an outer bound on distortion region for this case is given as follows. We assume there is a genie that reveals V_1 to the decoder 2 and V_2 to both the encoder 1 and the decoder 1. Similar to the derivation in section III, one obtains

$$D_{1ob} = \frac{\sigma_{V_1}^2 (1 - \rho^2)}{1 + P_1/N}. \quad (47)$$

$$D_{2ob} = \frac{\sigma_{V_2}^2 (1 - \rho^2)}{1 + P_2/N}. \quad (48)$$

From now on, we only present the outer bound 1 since in the numerical results we consider in the following, this outer bound is tighter than the outer bound 2. However, one can also derive the outer bound 2 for these cases and take the maximum of two by a similar way given in section III.

Numerical examples are given in Fig. 9 and 10, in which we set $\sigma_{V_1}^2 = \sigma_{V_2}^2 = N_1 = N_2 = 1$, $h_1 = h_2 = 0.5$, and the total power $P = 2$. The correlation between sources are $\rho = 0$ and $\rho = 0.3$, respectively. In both examples, we do not perform optimization over P_h and P_a with respect to particular criteria. Instead, we plot many choices of P_h and P_a which satisfy $P_2 = P_h + P_a$.

In Fig. 9, we observe that the proposed scheme achieves the outer bound at two corners in the absence of correlation. The left corner point can be achieved by assigning $P_2 = P$ and the right corner point can be achieved by setting $P_1 = P$. For other points except for two corner points, since the genie-aided outer bound may not be tight for the primary user (genie needs to reveal the V_2 to both the encoder and the decoder of the primary user), the outer bound is in general not tight. Despite this, the inner bound is close to the outer bound. In Fig. 10, we give an example where $\rho = 0.3$. One can observe that compared to the result in Fig. 9, the correlation helps both users in terms of distortion. And again, although the outer bound is not tight, the gap is reasonably small.

2. Non-Greedy Case: We now consider the case that the secondary user is willing to help the primary user. i.e., the $\gamma \in [0, 1]$. For this case, the outer bounds must be modified to address the fact that the secondary user uses a part of its power to transmit V_1 . For the primary user, suppose there is a genie that reveals V_2 and the HDA encoder to both encoder 1 and decoder 1, i.e., X_h is also known at both sides. We have

$$\begin{aligned} \frac{n}{2} \log \frac{\sigma_{V_1}^2 (1 - \rho^2)}{D_{1ob}} &\leq I(V_1; \hat{V}_1 | V_2) \leq I(V_1; Y_1 | V_2) \\ &= h(X_1 + h_1 X_2 + Z_1 | V_2, X_h) - h(Z_1) \\ &\leq h((1 + (1 - \gamma)\sqrt{a}h_1h_2) X_1 + Z_1) - h(Z_1) \\ &= \frac{n}{2} \log(1 + snr_1), \end{aligned} \quad (49)$$

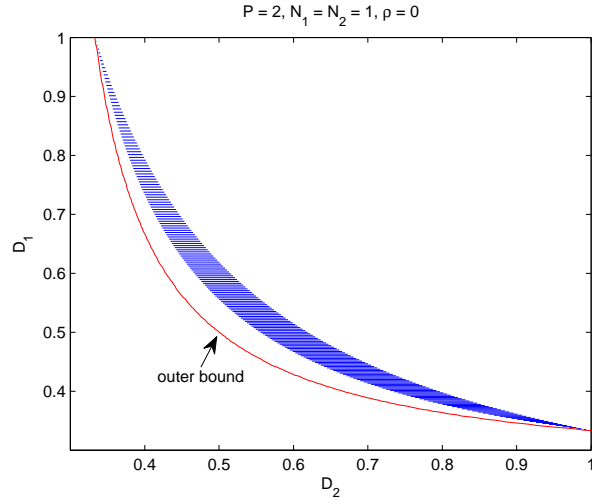
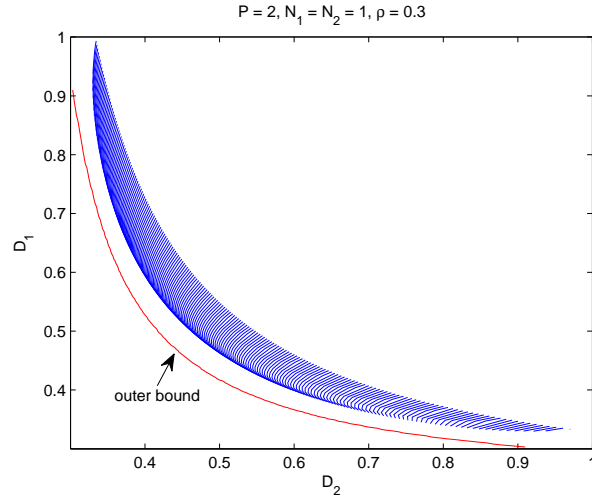
Fig. 9. Greedy case, $\rho = 0$.Fig. 10. Greedy case, $\rho = 0.3$.

where

$$snr_1 = \frac{P_1 (1 + (1 - \gamma)\sqrt{a}h_1h_2)^2}{N_1}. \quad (50)$$

Similarly, we assume a genie gives away V_1 to decoder 2 so that we have

$$\begin{aligned} \frac{n}{2} \log \frac{\sigma_{V_2}^2 (1 - \rho^2)}{D_{2ob}} &\leq I(V_2; \hat{V}_2 | V_1) \leq I(V_2; Y_2 | V_1) \\ &= h(X_2 + h_2 X_1 + Z_2 | V_1) - h(Z_2) \\ &\leq h(X_h + \gamma\sqrt{a}V_2 + Z_2) - h(Z_2) \\ &= \frac{n}{2} \log(1 + snr_2), \end{aligned} \quad (51)$$

where

$$snr_2 = \frac{P_h + a\gamma^2\sigma_{V_2}^2}{N_2}. \quad (52)$$

Thus, for each choice of P_1 , P_a , and γ we have the outer bound as

$$\tilde{D}_{1ob} = \frac{\sigma_{V_1}^2 (1 - \rho^2)}{1 + snr_1} \quad (53)$$

$$\tilde{D}_{2ob} = \frac{\sigma_{V_2}^2 (1 - \rho^2)}{1 + snr_2}. \quad (54)$$

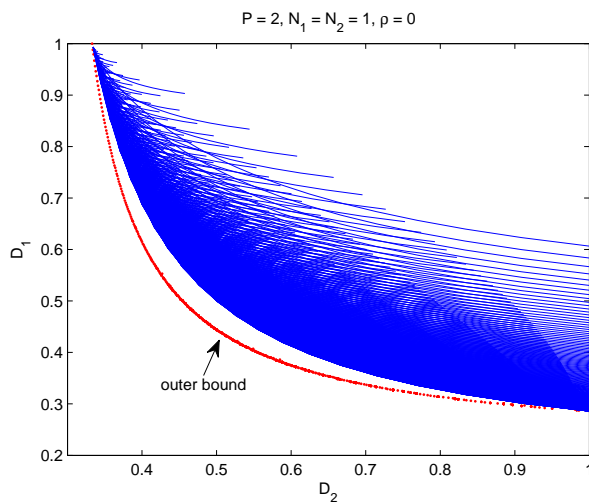
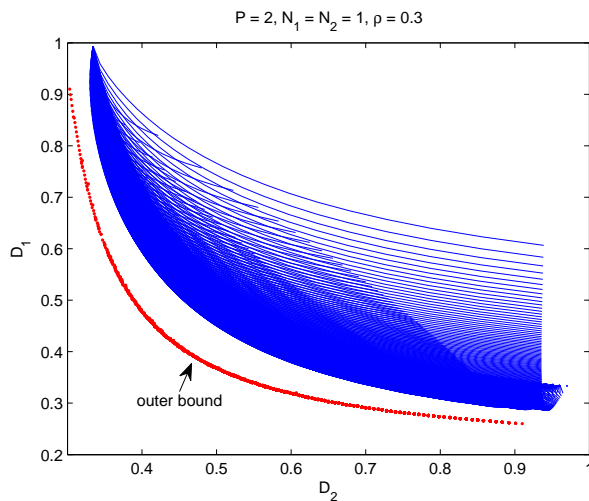
Fig. 11. Non-Greedy case, $\rho = 0$.Fig. 12. Non-Greedy case, $\rho = 0.3$.

The outer bound of this case is obtained by taking the lower convex envelope over all $(\tilde{D}_{1ob}, \tilde{D}_{2ob})$.

The numerical results for $\rho = 0$ and $\rho = 0.3$ are given in Fig. 11 and Fig. 12, respectively. In both figures, all the parameters are set to be the same as those in the previous two examples. We observe that if the secondary user is willing to help the primary user, the achievable distortion region is larger than that of greedy case.

3. *Coexistence Conditions*: In [6], the coexistence conditions are introduced to understand the system-wise benefits of cognitive radio. The authors study the largest rate that the cognitive radio can achieve under these coexistence constraint described as follows,

1. the presence of cognitive radio should not create rate degradation for the primary user, and
2. the primary user does not need to use a more sophisticated decoder than it would use in the absence of the cognitive radio. i.e, a single-user decoder is enough.

Similar to this idea, we study the distortion of the secondary user under the modified coexistence constraint as

1. the presence of cognitive radio should not increase distortion for the primary user, and
2. the primary user uses a single-user decoder.

Let the power constraints be P_1 and P_2 for the primary and secondary user, respectively, and $P_1 + P_2 = P$. In the absence of the cognitive radio, the distortion of the primary user is

$$D_1^* = \frac{\sigma_{V_1}^2}{1 + P_1/N_1}. \quad (55)$$

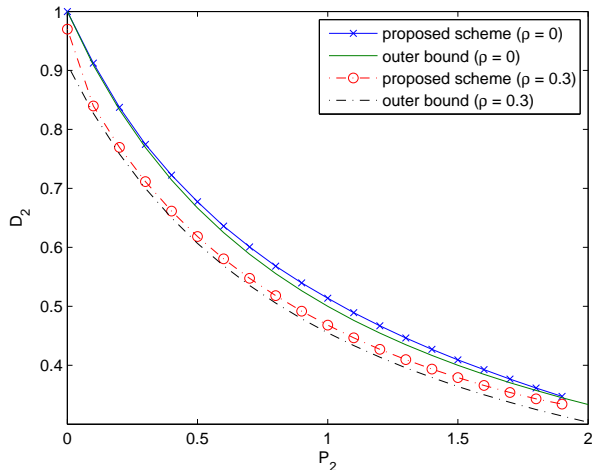

Fig. 13. Coexistence case, $\rho = 0$ and $\rho = 0.3$.

The outer bound on the secondary user under the coexistence conditions is given as

$$D_{coexist,ob} = \inf_{P_a, \gamma, \tilde{D}_{1ob} \leq D_1^*} \tilde{D}_{2ob}, \quad (56)$$

where \tilde{D}_{1ob} and \tilde{D}_{2ob} are given by (53) and (54), respectively. An example is shown in Fig. 13. All the parameters in this figure are the same with those in Fig. 9-12.

VII. CONCLUSIONS

In this paper, we have discussed the joint source-channel coding problem with interference known at transmitter. In particular, we considered the case that the source and the interference may have correlation with each other. According to the observations on the uncoded scheme and the naive DPC scheme, we proposed a separation-based scheme and a HDA scheme which can adapt with ρ . The performance of these two schemes under SNR mismatch are also discussed. Different from typical separation-based schemes suffering from the pronounced threshold effect in the presence of SNR mismatch, both the proposed schemes can benefit from a better side-information acquired at the decoder and thus, provide a graceful degradation under SNR mismatch. However, there is a difference between the performance of the two proposed schemes under a SNR mismatch and which scheme is better depends on the designed SNR and ρ .

These two schemes are then applied to cognitive radio channels and achievable distortion regions are discussed for different cases. To the best of our knowledge, this is the first joint source-channel coding scheme for cognitive radio channels. We have also provided outer bounds on these distortion regions. Despite the fact that the outer bounds are not tight in general, the numerical results have shown that the gap between the inner bound and the outer bound is reasonably small.

APPENDIX A DIGITAL WYNER-ZIV SCHEME

In this appendix, we summarize the digital Wyner-Ziv scheme for lossy source coding with side-information V' ($V = V' + W$ with $W \sim \mathcal{N}(0, D^*)$) at receiver. Suppose this side-information is available at both sides, the least required rate R_{WZ} for achieving a desired distortion D is [4]

$$R_{WZ} = \frac{1}{2} \log \frac{D^*}{D}. \quad (57)$$

Let us set this rate to be arbitrarily close to the rate given in (22), the rate that the channel can support with arbitrarily small error probability. The best possible distortion one can achieve for this setup is then given as

$$D = \frac{D^*}{1 + \frac{P - P_a}{N}}. \quad (58)$$

This distortion can be achieved as follows,

1. Let T be the auxiliary random variable given by

$$T = \alpha_{sep} V + B, \quad (59)$$

where

$$\alpha_{sep} = \sqrt{\frac{D^* - D}{D^*}} \quad (60)$$

and $B \sim \mathcal{N}(0, D)$.

2. The decoder first decodes to T (the decodability is guaranteed by the rate we chose) and then forms the MMSE from T and V' as $\widehat{V} = V' + \widehat{W}$ with

$$\widehat{W} = \frac{\alpha_{sep} D^*}{\alpha_{sep}^2 D^* + D} (T - \alpha_{sep} V'). \quad (61)$$

The corresponding distortion is given as

$$\begin{aligned} \mathbb{E}[(V - \widehat{V})^2] &= \mathbb{E}[(W - \widehat{W})^2] \\ &= D^* \left(1 - \frac{\alpha_{sep}^2 D^*}{\alpha_{sep}^2 D^* + D} \right) = D. \end{aligned} \quad (62)$$

APPENDIX B

WYNER-ZIV WITH MISMATCHED SIDE-INFORMATION

In this appendix, we calculate the expected distortion of the digital Wyner-Ziv scheme in the presence of side-information mismatch. Specifically, we consider the Wyner-Ziv problem with an i.i.d. Gaussian source and the MSE distortion measure. Let us assume that the best achievable distortion in the absence of side-information mismatch to be D . The encoder believes that the side-information is V' , and $V = V' + W$ with $W \sim N(0, D^*)$. However, the side-information turns out to be V'_a and has the relation $V = V'_a + W_a$ with $W_a \sim N(0, D_a^*)$. Under the same rate, we want to calculate the actual distortion D_a suffered by the decoder.

Since the encoder has been fixed to deal with the side-information, V' , at decoder, the auxiliary random variable is as in (59) with the coefficient given in (60).

Since the decoder knows the actual side-information, V'_a , perfectly, it only has to estimate W_a . By the orthogonality principle, the MMSE estimate \widehat{W}_a can be obtained as

$$\widehat{W}_a = \frac{\alpha_{sep} D_a^*}{\alpha_{sep}^2 D_a^* + D} (T - \alpha_{sep} V'_a) \quad (63)$$

Therefore, the estimate of the source is $\widehat{V} = V'_a + \widehat{W}_a$. The corresponding distortion is given as

$$\begin{aligned} D_a &= \mathbb{E}[(V - \widehat{V})^2] = \mathbb{E}[(W_a - \widehat{W}_a)^2] \\ &= \frac{D^* D_a^*}{D^* D_a^* + (D^* - D_a^*) D} D \end{aligned} \quad (64)$$

Here, we give an example in Fig. 14 to see the performance improvement through having the access of a better side-information. In this figure, we plot the $-10 \log_{10} D_a$ as $-10 \log_{10} D_a^*$ increases, i.e., as the actual side-information improves. The outer bound is obtained by assuming the transmitter always knows the distribution of actual side-information at decoder and the distortion of the HDA scheme is computed through derivations in [3] with a fixed coefficient

$$\kappa^2 = \frac{P^2}{(P + N) D^*} \quad (65)$$

at transmitter. The parameters are set to be $P = N = 1$ and $D^* = 0.1$. Therefore, without mismatch, the best achievable distortion is given as

$$D = \frac{D^*}{1 + P/N} = 0.05 \approx -13\text{dB}. \quad (66)$$

We can observe that both the digital Wyner-Ziv scheme and the HDA scheme benefit from a better side-information at decoder. Moreover, it can be seen that these two schemes provide the same performance under side-information mismatch.

APPENDIX C

DISCUSSIONS FOR SNR MISMATCH CASES

As discussed previously, both the separation-based scheme and the HDA scheme benefit from a better SNR. Here, we wish to analyze and compare the performance for these two schemes under SNR mismatch. Since the separation-based scheme makes estimate from T (see Appendix A) and V' (which is a function of Y) and the HDA scheme makes estimate from U and Y , it suffices to compare $I(V; T, Y)$ with $I(V; U, Y)$. By the chain rule of mutual information, we have

$$I(V; T, Y) = I(V; Y) + I(V; T|Y), \quad (67)$$

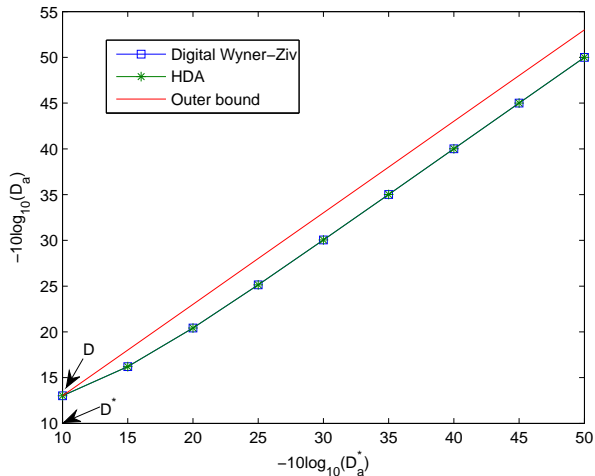

Fig. 14. Wyner-Ziv problem with side-information mismatch.

and

$$I(V; U, Y) = I(V; Y) + I(V; U|Y). \quad (68)$$

Thus, we only have to compare $I(V; T|Y)$ to $I(V; U|Y)$. Let us consider $\rho = 0$ case for example,

$$\begin{aligned} I(V; T|Y) &= h(T|Y) - h(T|V, Y) \\ &= h(\alpha_{sep}V + B|Y) - h(\alpha_{sep}V + B|V, Y) \\ &= h(\alpha_{sep}V - \alpha_{sep}\beta_a Y + B|Y) - h(\alpha_{sep}B|V, Y) \\ &= h(\alpha_{sep}W_a + B|Y) - h(B) \\ &\stackrel{(a)}{=} h(\alpha_{sep}W_a + B) - h(B) \\ &= \frac{1}{2} \log \frac{\alpha_{sep}^2 D_a^* + D}{D}, \end{aligned} \quad (69)$$

where α_{sep} and W_a are defined in Appendix B and (a) follows from the orthogonality principle.

$$\begin{aligned} I(V; U|Y) &= h(U|Y) - h(U|V, Y) \\ &= h(U|Y) - h(X_h + \alpha S' + \kappa V|V, Y) \\ &= h(U|Y) - h(X_h + \alpha S + (\kappa + \alpha\sqrt{a})V|V, Y) \\ &= h(U|Y) - h((1 - \alpha)X_h - \alpha Z_a|V, Y) \\ &\stackrel{(a)}{\geq} h(U|Y) - h((1 - \alpha)X_h - \alpha Z_a) \\ &= \frac{1}{2} \log \frac{\mathbb{E}[U^2] - \mathbb{E}[UY]^2/\mathbb{E}[Y^2]}{(1 - \alpha)^2 P_h + \alpha^2 N_a}. \end{aligned} \quad (70)$$

where (a) follows from that conditioning reduces entropy and the equality occurs if there is no SNR mismatch.

Two examples are given here to compare these two quantities with and without SNR mismatch for a small and a large designed SNR, respectively. In both Fig. 15 and 16, without SNR mismatch, these two quantities coincide with each other for all choices of P_a . This implies the result in section IV that without mismatch the separation-based scheme and the HDA scheme provide exactly the same distortion. However, for the small designed SNR case shown in Fig. 15, one observes that with SNR mismatch which quantity is larger really depends on P_a . On the other hand, for designed SNR = 10 dB case shown in Fig. 16, we see that with SNR mismatch, $I(V; U|Y) > I(V; T|Y)$ for a wide range of P_a (except for some P_a close to 1). This explains the results in section V that, for large designed SNRs, the HDA scheme has better results than the separation-based scheme does while for small designed SNRs we cannot make this conclusion easily.

REFERENCES

- [1] T. M. Cover and J. A. Thomas, *Elements of Information Theory*, New York: Wiley, 1991.
- [2] M. Costa, "Writing on dirty paper," *IEEE Trans. Inform. Theory*, vol. 29, no. 3, pp. 439-441, May 1983.
- [3] M. Wilson, K. Narayanan, and G. Caire, "Joint source channel coding with side information using hybrid digital analog codes," <http://arxiv.org/abs/0802.3851>.

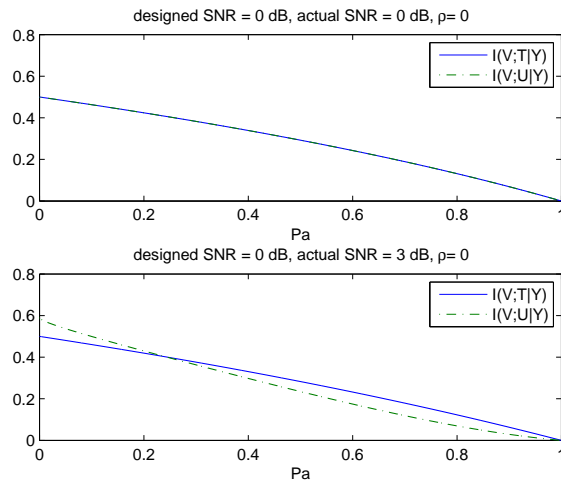

Fig. 15. Comparisons of (69) and (70) for designed SNR = 0 dB.

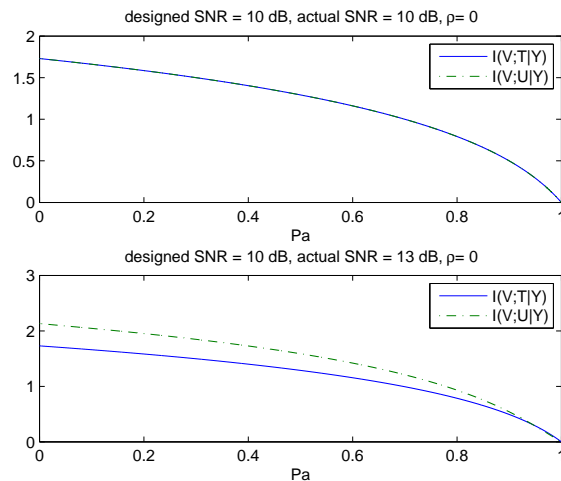

Fig. 16. Comparisons of (69) and (70) for designed SNR = 10 dB.

- [4] A. D. Wyner and J. Ziv, "The rate-distortion function for source coding with side information at the decoder," *IEEE Trans. Inform. Theory*, vol. 22, no. 1, pp. 1-10, Jan. 1976.
- [5] N. Devroye, P. Mitran, and V. Tarokh, "Achievable rates in cognitive radio channels," *IEEE Trans. Inform. Theory*, vol. 52, no. 5, pp. 1813-1827, May 2006.
- [6] A. Jovicic and P. Viswanath, "Cognitive radio: An information-theoretic perspective," *IEEE Trans. Inform. Theory*, Vol. 55, no. 9, pp. 3945-3958, Sept. 2009.
- [7] A. Lapidoth and S. Tinguely, "Sending a bi-variate Gaussian source over a Gaussian MAC," *IEEE Trans. Inform. Theory*, vol. 56, no. 6, pp. 2714-2752, Jun. 2010.
- [8] C. Tian, S. Diggavi, and S. Shamai, "The achievable distortion region of bivariate Gaussian source on Gaussian broadcast channel," <http://arxiv.org/abs/1006.0644>.
- [9] S. Shamai, S. Verdú, and R. Zamir, "Systematic lossy source/channel coding," *IEEE Trans. Inform. Theory*, vol. 44, no. 2, pp. 564-579, Mar. 1998.
- [10] R. Puri, K. Ramchandran, and S. Pradhan, "On seamless digital upgrade of analog transmission systems using coding with side information," in *Fortyeth Allerton Conference on Communication, Control and Computing*, Monticello, IL, Sept. 2002.
- [11] R. Soundararajan and S. Vishwanath, "Hybrid coding for Gaussian broadcast channels with Gaussian sources," in *Proc. IEEE International Symposium on Information Theory*, Seoul, Korea, Jul. 2009, pp. 2790-2794.
- [12] A. Sutivong, M. Chiang, T. M. Cover, and Y.-H. Kim, "Channel capacity and state estimation for state-dependent Gaussian channels," *IEEE Trans. Inform. Theory*, vol. 51, no. 4, pp. 1486-1495, Apr. 2005.
- [13] T. J. Goblick, "Theoretical limitations on the transmission of data from analog sources," *IEEE Trans. Inform. Theory*, vol. 11, no. 4, pp. 558-567, Oct. 1965.
- [14] M. Gastpar, B. Rimoldi, and Vetterli, "To code, or not to code: lossy source-channel communication revisited," *IEEE Trans. Inform. Theory*, vol. 49, no. 5, pp. 1147-1158, May 2003.
- [15] J. Mitola, "Cognitive Radio," Ph.D. dissertation, Royal Institute of Technology (KTH), Stockholm, Sweden, 2000.
- [16] T. Han and K. Kobayashi, "A new achievable rate region for the interference channel," *IEEE Trans. Inform. Theory*, vol. 27, no. 1, pp. 49-60, Jan. 1981.