

# DYNAMIC CHARACTERISTICS OF A THIN FILM OPTOELECTRONIC VOLTAGE-CURRENT CONVERTOR

Z. PORADA

*Institute of Electrical Engineering (E-1), Technical University, Warszawska 24, 31-155 Cracow,  
Poland*

E. SCHABOWSKA-OSIOWSKA

*Institute of Electronics, Academy of Mining and Metallurgy, Al. Mickiewicza 30, 30-059 Cracow,  
Poland*

*(Received March 18, 1993; in final form April 12, 1993)*

## 1. INTRODUCTION

The voltage-light-current convertor is a device composed of an electroluminescent cell and a photoconductive element coupled optically. The voltage applied to the electroluminescent cell brings about the emission of light, which, owing to unidirectional optical coupling, illuminates the photoconductive element, thereby increasing its conductance as well as the current passage through this element.

This convertor is interesting in consideration of the possibility of its utilization in optoelectronic systems<sup>1</sup>, as well as in various systems for industrial automation and telecommunication, in which it can serve as a separator.

In the present work, the dependence of the output current in a photoconductive element on the input voltage applied to the electroluminescent cell, was measured for a real convertor.

The results of measurements of dynamic characteristics of the optoelectronic voltage/current convertor are also presented.

The characteristics have shown good conformity with theoretical curves calculated on our proposed mathematical model.

## 2. THEORETICAL MODEL

The theoretical model of a voltage-light-current type thin film convertor was elaborated on the basis of an electrical equivalent circuit shown in Figure 1. This assumes that the input voltage  $U_{EL}$  applied to the electroluminescent cell is a sinusoidal voltage, and the voltage  $U_{PC}$  supplying the input circuit with the photoconductive element can be a constant voltage as well as a sinusoidal voltage.

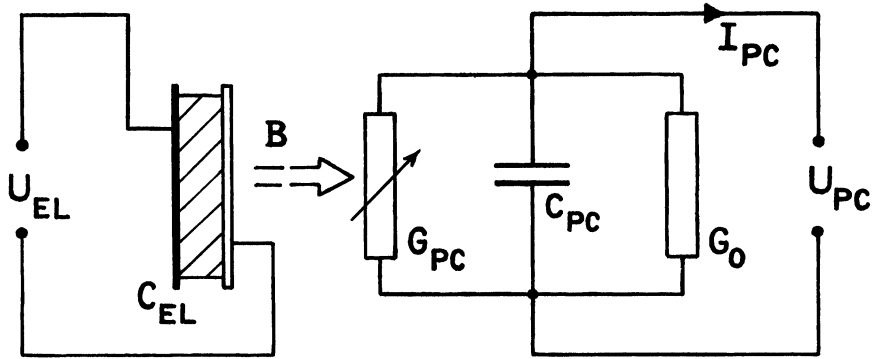

FIGURE 1 Electrical equivalent circuit of a voltage-light-current type converter

For the description of the luminance  $B$  of the light from the electroluminescent cell, the formula given by Alfrey and Taylor<sup>2</sup> has been used:

$$B(t) = B_0 \exp(-\gamma t) \exp \left[ \frac{-b}{\sqrt{|U_{EL}(t)|}} \right] \quad (1)$$

where  $B$  is the mean value of luminance,  $B_0$ ,  $\gamma$ , and  $b$  are constant parameters for a given electroluminescent cell, and  $U_{EL}$  is the actual value of sinusoidal voltage applied to the cell.

In the investigated converter, an unidirectional optical coupling occurs. Thus, the light emitted from the electroluminescent cell will illuminate the photoconducting element, modifying its conductance, and thereby the value of  $I_{PC}$  current through this element. The current  $I_{PC}$  can be given<sup>3</sup> by the formula

$$I_{PC} = C_{PC} \frac{d}{dt} U_{PC} + G_{PC} U_{PC} \quad (2)$$

where  $C_{PC}$  is the capacity of the photoconducting element, while the conductance  $G_{PC}$  is described<sup>4</sup> by the formula

$$G_{PC} = \frac{e^2 \tau}{m_e} (1 + \omega^2 \tau^2)^{-1} (n_0 + \Delta n) \quad (3)$$

where  $e$  and  $m_e$  are the charge and the mass of an electron, respectively,  $\tau$  is the relaxation time,  $\omega$  is the angular frequency,  $n_0$  is the dark concentration of charge carriers,  $\Delta n$  is the increase in concentration of charge carriers caused by illumination of the photoconducting element, and  $U_{PC}$  is the voltage supplying the photoconducting element:

$$U_{PC} = U_{0PC} \sin(\omega_{PC} t + \varphi_{PC}) \quad (4)$$

whereas  $\Delta n$  can be calculated from the equation

$$\frac{d}{dt} \Delta n = \alpha \eta \beta_1 B(t) - \frac{\Delta n}{\tau_n} \quad (5)$$

in which  $\beta_1$  is the unidirectional optical coupling coefficient, determined by the geometry and by the degree of spectral overlap of the electroluminescent cell and the photoconductive element,  $\alpha$  is the light absorption coefficient,  $\eta$  is the quantum yield and  $\tau_n$  is the photoconductivity rise time.

Thus, the dynamical characteristics of the convertor with unidirectional optical coupling can be calculated by solving the set of equations:

$$I_{PC} = C_{PC} \frac{d}{dt} U_{PC} + U_{PC} \frac{e^2 \tau}{(1 + \omega^2 \tau^2) m_e} (n_0 + \Delta n) \quad (6)$$

$$\frac{d}{dt} \Delta n = \alpha \eta \beta_1 B_0 \exp(-\gamma t) \exp \left[ -\frac{b}{\sqrt{|U_{EL}|}} \right] - \frac{\Delta n}{\tau_n} \quad (7)$$

If the electrical circuit with an photoconducting element is supplied with voltage  $U_{PC}$  constant in time, equation (6) has the form

$$I_{PC} = U_{PC} \frac{e^2 \tau}{m_e} [n_0 + \Delta n(t)] \quad (8)$$

Solving the set of equations (6) and (7) one can obtain the course of the current  $I_{PC}$  vs. time for the voltage  $U_{PC}$  constant in time. From the set of equations (7) and (8), the dependence of the current  $I_{PC}$  on time for the sinusoidal voltage  $U_{PC}$  can be obtained.

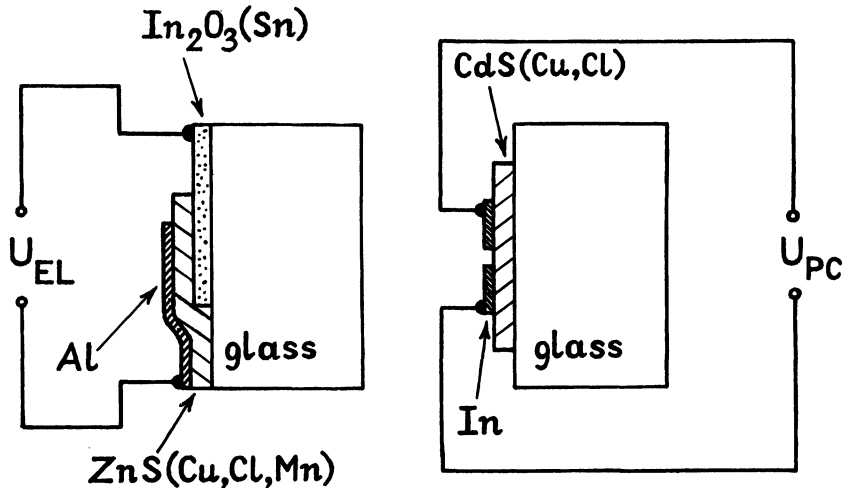

FIGURE 2 The arrangement of a voltage-light-current type thin film convertor

### 3. RESULTS OF EXPERIMENTAL INVESTIGATIONS

The examined convertor was composed (Fig. 2) of two separately executed elements, the first of which, the electroluminescent cell, was prepared as a sandwich-type system on a glass substrate. The first layer was a transparent, conducting  $\text{In}_2\text{O}_3(\text{Sn})$  electrode, the second layer was a  $\text{ZnS}(\text{Cu}, \text{Cl}, \text{Mn})$  film evaporated under vacuum, and the third layer, the upper electrode, was a vacuum-evaporated thin aluminium film<sup>5</sup>.

The second element of the convertor, the photoconductive element, was composed of a CdS film doped with copper and chlorine and evaporated under vacuum on an alundum substrate, and by two indium electrodes deposited on it<sup>6</sup>.

In the convertor described above, the dependence of the current  $I_{\text{PC}}$  in the photoconductive element on the voltage  $U_{\text{EL}}$  applied to the electroluminescent cell was measured. The current  $I_{\text{PC}}$  was measured for output circuit supplied with constant voltage.

In Figure 3, the dependence of the output current  $I_{\text{PC}}$  on the input voltage  $U_{\text{EL}}$  for the three input voltage frequencies—200 Hz, 500 Hz, and 1000 Hz—is presented. The output circuit with the photoconductive element was supplied with constant voltage 100 V.

For supplying the output circuit with constant voltage 100 and 200 V, the current  $I_{\text{PC}}$  was proportionally lower.

In Figure 4, the dependence of the current  $I_{\text{PC}}$  on the time for a convertor supplied with the sinusoidal value  $U_{\text{EL}}$  with amplitude 280 V and frequency 500

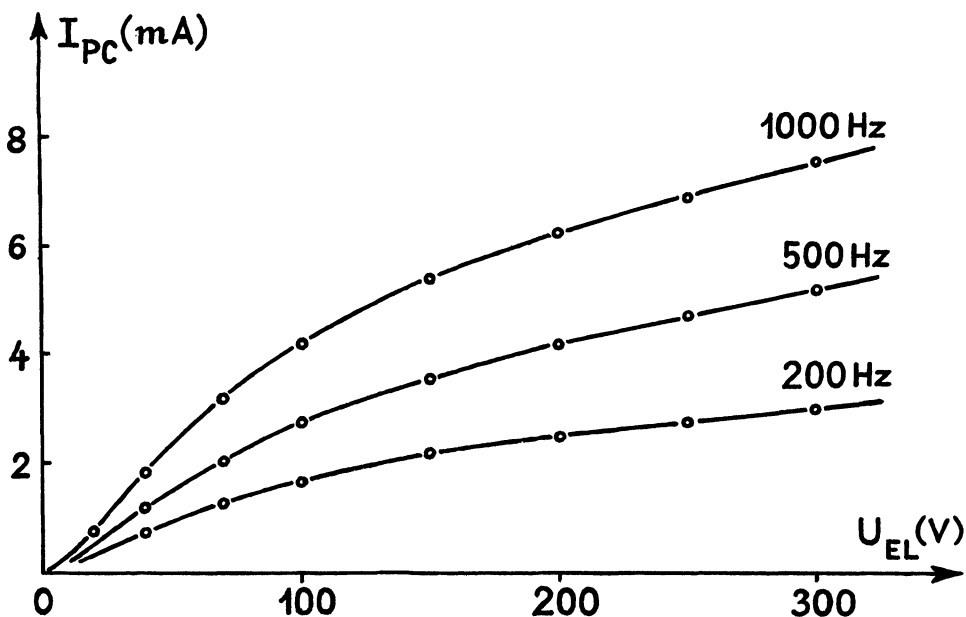

FIGURE 3 Dependence of the current  $I_{\text{PC}}$  on the voltage  $U_{\text{EL}}$  for  $U_{\text{PC}} 100 \text{ V}$

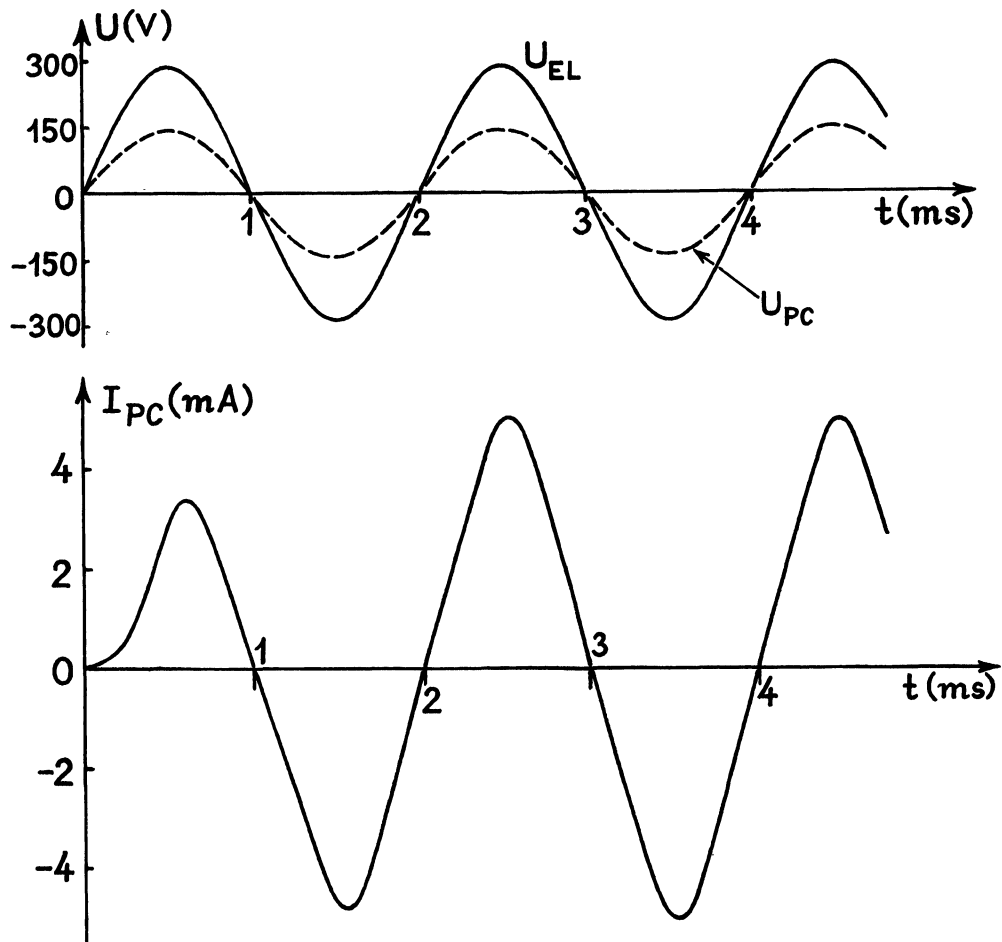

FIGURE 4 Dependence of the current  $I_{PC}$  on time for amplitude  $U_{EL}$  280 V and frequency 500 Hz and for amplitude  $U_{PC}$  140 V and frequency 500 Hz

Hz and with the sinusoidal voltage  $U_{PC}$  with amplitude 140 V and frequency 500 Hz is shown.

In Figure 5, the dependence of the current  $I_{PC}$  vs. time for supplying the convertor with sinusoidal voltage  $U_{EL}$  of amplitude 280 V and frequency 500 Hz and for the voltage  $U_{PC}$  constant in time, 100 V, is shown.

#### 4. CONCLUSIONS

Both the measurements and the analysis of the proposed theoretical model have shown that the output current for a voltage-light-current type convertor depends on the input voltage  $U_{EL}$ , on the frequency of this voltage, and on the voltage  $U_{PC}$  supplying the output circuit of the convertor.

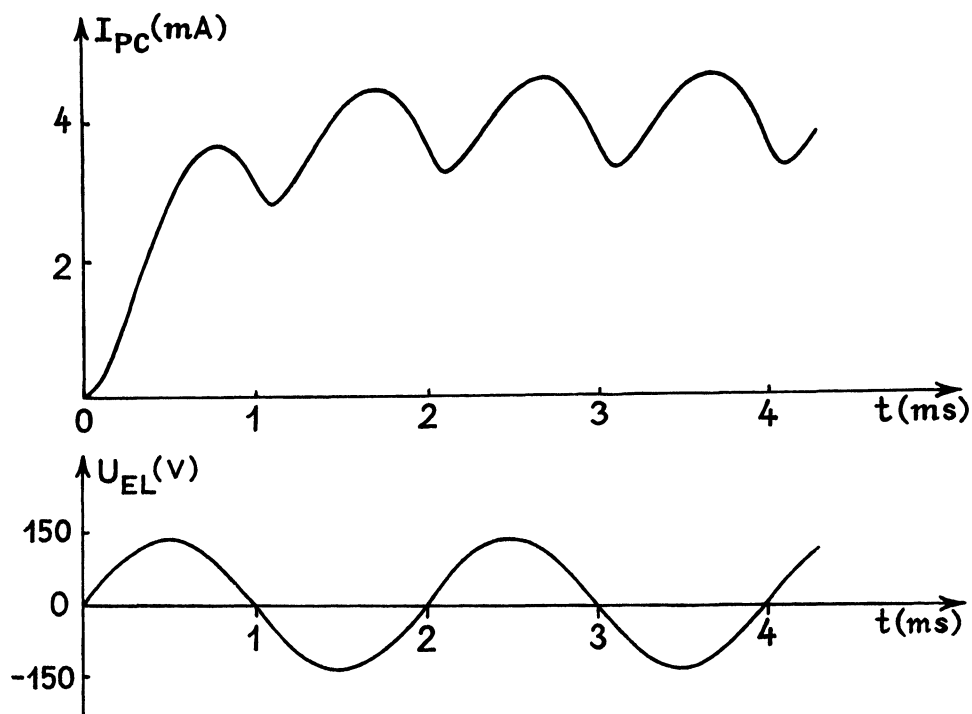

FIGURE 5 Dependence of the current  $I_{PC}$  on time for amplitude  $U_{EL}$  280 V and frequency 500 Hz and for constant voltage  $U_{PC}$  100 V

As can be seen from the Figure 3, an increase in the  $U_{EL}$  voltage frequency results in the increase of the current  $I_{PC}$ .

The dynamic characteristics show that at the supply of the convertor with constant voltage  $U_{PC}$ , the current  $I_{PC}$  making the output signal of the convertor is a pulsating current with minor constant component. At the supply of the convertor with sinusoidal voltage  $U_{PC}$ , the current  $I_{PC}$  has the character of an alternating current with weak distortions from sinusoidal shape.

#### REFERENCES

1. H.K. Henish, *Electroluminescence*, Pergamon, Oxford 1962.
2. G.F. Alfrey and J.B. Taylor, *Br. J. Appl. Phys.*, **4**, 44S (1955).
3. Z. Porada and E. Schabowska, *Thin Solid Films*, **164**, 411 (1988).
4. Z. Porada, E. Schabowska and J. Turczak, *Thin Solid Films*, **65**, 137 (1980).
5. Z. Porada and E. Schabowska, *J. Luminescence*, **21**, 129 (1980).
6. Z. Porada and E. Schabowska, *Thin Solid Films*, **66**, L55 (1980).