

UNIVERSAL COVERS AND THE GW/KRONECKER CORRESPONDENCE

JACOPO STOPPA

ABSTRACT. The tropical vertex is an incarnation of mirror symmetry found by Gross, Pandharipande and Siebert. It can be applied to m -Kronecker quivers $K(m)$ (together with a result of Reineke) to compute the Euler characteristics of the moduli spaces of their (framed) representations in terms of Gromov-Witten invariants (as shown by Gross and Pandharipande). Motivated by the question of whether this computation reflects an equivalence of objects, here we consider the operation of passing to the universal cover of the quiver, $\widetilde{K(m)}$, and propose a “mirror” for this. For the standard Kronecker quiver $K(2)$ this is enough to construct a curve from a framed representation, but the general situation is more complicated. Additional motivation for studying the universal cover in terms of curves comes from the physical interpretation of m -Kronecker quivers in the context of quiver quantum mechanics.

1. INTRODUCTION

1.1. **The correspondence.** The m -Kronecker quiver $K(m)$ is the bipartite quiver with m edges directed from v_1 (the *source*) to v_2 (the *sink*):

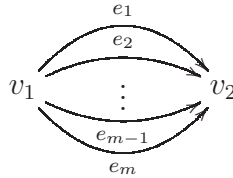

A stability condition (central charge) for its dimension vectors is specified by a pair of integers (w_1, w_2) . We will always refer to the choice $(w_1, w_2) = (1, 0)$. One can then form smooth, projective moduli spaces $\mathcal{M}_m^{(1,0),B}(d)$ for stable representations of $K(m)$ with dimension vector d and a 1-dimensional framing at v_1 (respectively $\mathcal{M}_m^{(1,0),F}(d)$ for a framing at v_2 , see [ER] for the general theory). By the results of Engel and Reineke we have closed formulae for the generating functions of the topological Euler characteristics $\sum_d \chi(\mathcal{M}_m^{(1,0),B}(d)) x^d$.

Here however we are interested in an alternative and rather surprising way of computing these Euler characteristics, using an incarnation of mirror symmetry known as the tropical vertex of Gross, Pandharipande and Siebert [GPS]. It turns out that computing the generating function

$$\sum_{k \geq 0} \chi(\mathcal{M}_m^{(1,0),B}(ka, kb)) x^{ka} y^{kb}$$

is equivalent to working out a Gromov-Witten theory for a family of algebraic surfaces.

Fix coprime positive integers a, b and let $\mathbb{P}(a, b, 1)$ be the weighted projective plane $(\mathbb{C}^3 \setminus \{0\})/\mathbb{C}^*$, with action given by $\lambda \cdot (z_1, z_2, z_3) = (\lambda^a z_1, \lambda^b z_2, \lambda z_3)$. Its toric fan is given by the duals of the divisors D_1, D_2, D_{out} cut out by z_1, z_2, z_3 . We denote by $D_1^o, D_2^o, D_{\text{out}}^o$ the subschemes obtained by removing the three torus fixed points. Then roughly speaking, the relevant invariants for us are

$$N_{a,b}[(P_a, P_b)] \in \mathbb{Q}$$

counting rational curves in the weighted projective plane $\mathbb{P}(a, b, 1)$ which pass through m -tuples of distinct points x_1^1, \dots, x_m^1 on D_1^o , respectively x_1^2, \dots, x_m^2 on D_2^o , with multiplicities specified by length m ordered partitions P_a, P_b with $|P_a| = ka, |P_b| = kb$ and which are tangent to D_{out}^o to order k .

As an example $N_{1,1}(2+1, 1+1+1) = 3$ counts plane rational cubics with a prescribed node which pass through 4 other prescribed points, and with D_{out} an inflectional tangent.

We refer to [GPS] Sections 0.4 and 6.4 for precise definitions and further examples. The numbers $N_{a,b}[(P_a, P_b)]$ are well defined and independent of the choice of points.

The GW/ m -Kronecker correspondence is the identity in $\mathbb{Q}[[x, y]]$

$$\begin{aligned} \exp \left(\sum_{k \geq 1} \sum_{|P_a|=ka, |P_b|=kb} k N_{a,b}[(P_a, P_b)] x^{ka} y^{kb} \right) \\ = \left(1 + \sum_{k \geq 1} \chi(\mathcal{M}_m^{(1,0),B}(ka, kb)) x^{ka} y^{kb} \right)^{\frac{m}{a}} \\ = \left(1 + \sum_{k \geq 1} \chi(\mathcal{M}_m^{(1,0),F}(ka, kb)) x^{ka} y^{kb} \right)^{\frac{m}{b}}, \end{aligned} \tag{1.1}$$

(summing over length m ordered partitions P_a, P_b), first written down explicitly by Gross and Pandharipande [GP] Corollary 3.

The formula (1.1) arises indirectly, by comparing two ways of computing a commutator in the tropical vertex group (also known as Kontsevich-Soibelman group), namely either in terms of quiver representations using Reineke's result [Re] Theorem 2.1, or in terms of GW invariants of orbifold surfaces using the tropical vertex. The commutator expresses a Kontsevich-Soibelman wall-crossing ([KS] Section 1.4) for χ at different choices of the central charge.

Gross and Pandharipande [GP] Section 3.5 and Reineke [Re] Section 6 have asked if there is actually a correspondence between curves and representations underlying the equality (1.1). In particular one could ask how to construct a rational curve starting from a given framed representation of $K(m)$. We argue here that a first step in this direction is to understand the *universal cover* $\widetilde{K(m)}$ (recalled below) in terms of curves.

We will see in Section 2.2 that for the standard Kronecker quiver $K(2)$ one can indeed associate a (tropical) curve with a framed finite representation of $\widetilde{K(2)}$ (which in this case is the same as the *abelian* universal cover $\widehat{K(2)}$). By the results of Weist [We] passing to $\widehat{K(2)}$ is the same as localising with respect to the natural $(\mathbb{C}^*)^2$ -action, so the Euler characteristics can be computed already on $\widetilde{K(2)}$ (Weist proves a similar result in the general case of $K(m)$, as we will discuss below).

When $m \geq 3$ however this approach becomes problematic. This is explained by an example in Section 2.2. Roughly speaking, if we think of $Q \subset \widetilde{K(m)}$ as a localisation quiver for $K(m)$ under the natural $(\mathbb{C}^*)^m$ -action, then we may say that Q is not a local enough object, and a single framed representation can give rise to infinitely many curves.

So it seems important to shift attention to the easier question, what is the “mirror” of passing to the universal cover $\widetilde{K(m)}$?

Main result (very imprecise version). *Passing to the universal cover corresponds to partitioning quiver representations according to boundary conditions, specified by a parameter \tilde{d} . Similarly, one can partition the curves appearing in (1.1) according to boundary conditions, with a parameter \mathbf{w} . Then \tilde{d} and \mathbf{w} are “mirror” under (1.1).*

We try to make this precise in the discussion below, and in particular with formulae 1.4 and 1.5.

1.2. Universal covers. Let Q be a quiver without closed loops, with vertices Q_0 and edges Q_1 .

The algebraic torus $T := (\mathbb{C}^*)^{|Q_1|}$ acts on the affine spaces of representations $\text{Rep}_Q(d)$ for $d \in \mathbb{N}Q_0$, by scaling the linear maps in a representation. Let us write $X(T) := \text{Hom}(T, \mathbb{C}) \cong \mathbb{Z}Q_1$, the character group of T .

The *abelian universal cover* of Q (due to Reineke, see [We] Section 3) is the quiver \widehat{Q} with vertices $\widehat{Q}_0 = Q_0 \times X(T)$ and arrows given by

$$(\alpha, \chi): (i, \chi) \rightarrow (j, \chi + e_\alpha)$$

for $\alpha: i \rightarrow j$ in Q_1 and $\chi \in X(T)$. Here e_α is the character corresponding to $\alpha \in Q_1$. We say $\hat{d} \in \mathbb{N}\widehat{Q}_0$ is compatible with $d \in \mathbb{N}Q_0$ if $d_i = \sum_\chi \hat{d}_{i,\chi}$ for all $i \in Q_0$. There is an action of $\mathbb{Z}Q_1$ on \widehat{Q}_0 defined by $\lambda \cdot (i, \chi) = (i, \chi + \lambda)$, which extends to an action on $\mathbb{N}\widehat{Q}_0$ by linearity. In the following we will denote by $[\hat{d}]$ the equivalence class of $\hat{d} \in \mathbb{N}\widehat{Q}_0$.

Let now $W(Q)$ be the group of words on Q , generated by arrows and their formal inverses. The *universal cover* \widetilde{Q} of Q (see [We] Section 3.4) is the quiver with vertices $\widetilde{Q}_0 = Q_0 \times W(Q)$ and arrows given by

$$(\alpha, w): (i, w) \rightarrow (j, w\alpha)$$

for $\alpha: i \rightarrow j$ in Q_1 and $w \in W(Q)$. As in the abelian case we have the notion of a compatible dimension vector $\tilde{d} \in \mathbb{N}\widetilde{Q}_0$ for $d \in \mathbb{N}Q_0$ and an action of $W(Q)$ on $\mathbb{N}\widetilde{Q}_0$ with equivalence classes $[\tilde{d}]$.

Weist studied the fixed locus for the torus action, proving the decomposition

$$(\mathcal{M}_Q^s(d))^T \cong \bigcup_{[\hat{d}]} \mathcal{M}_{\widehat{Q}}^s(\hat{d}).$$

In turn each of the moduli spaces $\mathcal{M}_{\widehat{Q}}^s(\hat{d})$ admits a torus action, and this gives rise to a tower of fixed loci, each described by representations of iterated abelian covers, [We] Section 3.4. The main result in this connection is [We] Theorem 3.16, stating that for fixed d these iterations stabilise to the disjoint union over compatible dimension vectors of the universal cover,

$$\bigcup_{[\tilde{d}]} \mathcal{M}_{\widetilde{Q}}^s(\tilde{d}).$$

Applying these results to $K(m)$ gives identities for the topological Euler characteristics,

$$\chi(\mathcal{M}_{K(m)}^s(d)) = \sum_{[\hat{d}]} \chi(\widehat{\mathcal{M}}_{K(m)}^s(\hat{d}))$$

and, more importantly for us,

$$\chi(\mathcal{M}_{K(m)}^s(d)) = \sum_{[\tilde{d}]} \chi(\mathcal{M}_{\widehat{K(m)}}^s(\tilde{d})) \quad (1.2)$$

(here there is no framing, so we have to assume the dimension vector $d = (d_1, d_2)$ is coprime; the same result holds for all dimension vectors for framed representations, by summing up over all B or F -framings on the universal cover).

Notice that while $\widehat{K(m)}$ cannot contain oriented cycles, it may well contain unoriented ones: the first instance is the infinite hexagonal quiver with an orientation, isomorphic to $\widehat{K(3)}$ (see Figure 1). In general, it is much better to work with the universal cover, which cannot contain cycles; indeed $\widetilde{K(m)}$ can be identified with the infinite m -regular quiver with a choice of orientation (e.g. by “opening up” the quiver in Figure 1). Then one can

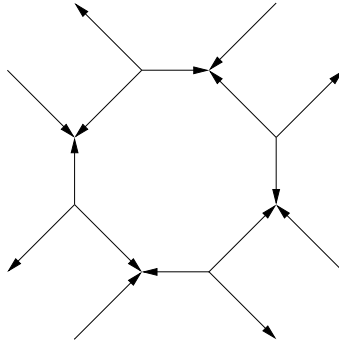

FIGURE 1. The universal abelian cover $\widehat{K(3)}$.

construct a representation of $K(m)$ uniquely from a finite representation of $\widetilde{K(m)}$ plus an *admissible colouring* of the arrows by $\{1, \dots, m\}$, i.e. one for which arrows outgoing from (or incoming to) the same vertex are coloured differently (see [We] Remark 5.13), up to symmetries of the colouring.

Next we try to find an analogue of Weist’s identity (1.2) for the GW invariants appearing in the GW/ m -Kronecker correspondence. A lot of our motivation comes from a construction in physics which we learnt from a paper of Denef [De].

1.3. Physical picture. We now briefly turn to the physical interpretation of $K(m)$, giving a very naive and imprecise account.

Let S_1, S_2 be two Lagrangian 3-spheres in a compact Calabi-Yau threefold X , meeting transversely and positively in m points, so for the intersection

product (the DSZ product in this context) we have $\langle [S_1], [S_2] \rangle = m$. In the terminology of [De] Section 3.1 S_1, S_2 are parton D3-branes. The generalised Kronecker quiver $K(m)$ with dimension vector $d = (d_1, d_2)$ arises in the study of the string theory on spacetime compactified on X with m open strings with boundaries on one of d_1 D-branes of type $[S_1]$ and one of d_2 D-branes of type $[S_2]$.

The fundamental parameter in this theory is the string coupling constant g_s . For positive $g_s \approx 0$, and when the D-branes have small but nonvanishing phase difference and spacetime separation, the theory becomes a quiver quantum mechanics modelled on $K(m)$. In particular the Witten index of the theory can be computed as $\chi(\mathcal{M}_{K(m)}(d))$.

A very different picture emerges for large coupling constant g_s . In this regime the BPS states for the theory become multi-centered, molecule-like configurations of d_1 “monopoles” with charge \mathbf{Q} and d_2 “electrons” with charge \mathbf{q} , with DSZ product $\langle \mathbf{Q}, \mathbf{q} \rangle = m$ (i.e. the “monopoles” have magnetic charge m , the “electrons” have electric charge 1). What (1.2) says in this regime is that we can compute the same Witten index by summing over all multi-centered BPS configurations with charges $\mathbf{Q}_1, \dots, \mathbf{Q}_{\ell_1}$ and $\mathbf{q}_1, \dots, \mathbf{q}_{\ell_2}$ such that the DSZ product $\langle \mathbf{Q}_i, \mathbf{q}_j \rangle$ is at most 1 for $i = 1 \dots, \ell_1, j = 1, \dots, \ell_2$ (i.e. such that each pair of interacting particles looks like a simple monopole-electron system, corresponding to $K(1)$). The $\widetilde{K(m)}$ constraint in this regime means that the splitting into charges $\mathbf{Q}_i, \mathbf{q}_j$ must be compatible with the original DSZ product $\langle \mathbf{Q}, \mathbf{q} \rangle = m$. From this point of view replacing $\widetilde{K(m)}$ by $\widehat{K(m)}$ means that for these multi-centered configurations one cannot have closed chains of interacting monopoles-electrons.

For each of these multi-centered configurations, going back to $g_s \approx 0$ will give theories based on configurations of partons, with the same total Witten index. In other words one can compute the total Witten index by summing up over all the ways of splitting the boundary conditions for the open strings.

Another advantage of the large g_s viewpoint is an interpretation of Weist’s gluing result [We] Corollary 5.28.

Mathematically, in its simplest form, this says that if we have two representations R', R'' of $\widetilde{K(m)}$ with dimension vectors d', d'' and skew-symmetrised Euler form $\langle d', d'' \rangle = 1$ (we also call this DSZ product, recalled in Section 2.1 below), we can glue them by identifying two sinks $j' \in R'_0, j'' \in R''_0$. The new dimension vector is $d = d' + d''$.

Now from the $g_s \gg 0$ perspective we are simply superimposing our two special multi-centered configurations at two “electrons”. Weist’s gluing corresponds to the statement that the total configuration we obtain is BPS, as

long as the two multi-centered configurations behave mutually like a simple monopole-electron system,

$$\langle \sum_i \mathbf{Q}'_i + \sum_j \mathbf{q}'_j, \sum_i \mathbf{Q}''_i + \sum_j \mathbf{q}''_j \rangle = 1.$$

Notice that so far we have ignored the framing, but this could easily be introduced by adding an additional parton D-brane S to the discussion above.

Finally we should mention that the special case $m = 2$ (with framing) has a physical interpretation as a certain $SU(2)$ Seiberg-Witten theory, as discussed in [GMN] Section 2.2. The choice of stability condition corresponds to a choice of coupling regime. The Kontsevich-Soibelman wall-crossing formula has been interpreted in the context of Seiberg-Witten theories by Gaiotto, Moore and Nietzke [GMN]. In the special case $m = 2$ the relevant identity is (using Kontsevich-Soibelman operators on $K(2)$, to be recalled below)

$$T_{1,0} \circ T_{0,1} = T_{0,1} \circ T_{1,2} \circ T_{2,3} \cdots T_{1,1}^{-1} \cdots T_{3,2} \circ T_{2,1} \circ T_{1,0}$$

which they interpret as going from strong coupling (the only BPS states are a single monopole and a single dyon) to weak coupling (one finds an infinite tower of dyons plus a W boson, plus 4 hypermultiplets).

In Section 2.2, when we discuss the correspondence with curves, we will give examples of what are the curves that carry a contribution to the operator which represents one of these states.

1.4. “Boundary conditions” (legs) for curves. What we wish to retain from this physical picture is that passing to the universal cover for quiver representations corresponds to splitting either *boundary conditions* (i.e. D-branes, partons) for small g_s or particles (for large g_s) into a number of constituents. Then we can recover χ by summing up over all configurations of all possible types.

We now turn to the left hand side of the GW/ m -Kronecker correspondence (1.1), that is to curves in weighted projective planes. There is no obvious analogue of the $(\mathbb{C}^*)^m$ -action here, however we propose that an analogue of the equality (1.2) is given by the formula in terms of tropical counts ([GPS] Proposition 5.3)

$$N_{a,b}[(P_a, P_b)] = \sum_{\mathbf{w}} \frac{N^{\text{trop}}(\mathbf{w})}{|\text{Aut}(\mathbf{w})|} R_{P|\mathbf{w}}. \quad (1.3)$$

The sum is over positive, increasing weight vectors $\mathbf{w} = (\mathbf{w}_1, \mathbf{w}_2)$,

$$\mathbf{w}_i = (w_{i1}, \dots, w_{il_i})$$

that may refine the ordered partitions $P = (P_a, P_b)$

$$\begin{aligned} P_a &= (p_{a1}, \dots, p_{al_a}) \\ P_b &= (p_{b1}, \dots, p_{bl_b}). \end{aligned}$$

(so we think of \mathbf{w} as the analogue of a compatible dimension vector).

It can also be seen as a sum over refinements of P ; the multiplicity term is contained in

$$R_{P|\mathbf{w}} = \sum_{I_\bullet} \prod_{j=1}^{l_1} \frac{(-1)^{w_{1j}-1}}{w_{1j}^2} \cdot \sum_{J_\bullet} \prod_{j=1}^{l_2} \frac{(-1)^{w_{2j}-1}}{w_{2j}^2},$$

where we sum over all compatible set partitions, i.e. disjoint unions

$$\{1, \dots, l_1\} = \bigcup_r I_r, \quad \{1, \dots, l_2\} = \bigcup_s J_s$$

such that

$$p_{ar} = \sum_{i \in I_r} w_{1i}, \quad p_{bs} = \sum_{j \in J_s} w_{2j}.$$

Here

$$\text{Aut}(\mathbf{w}) = \text{Aut}(\mathbf{w}_1) \times \text{Aut}(\mathbf{w}_2)$$

where $\text{Aut}(\mathbf{w}_i) \leq \Sigma_{l_i}$ is the stabiliser of $(w_{i1}, \dots, w_{il_i})$ in the symmetric group, for $i = 1, 2$.

Later we will also need arbitrary weight vectors $\mathbf{w} = (\mathbf{w}_1, \dots, \mathbf{w}_L)$, together with their stabiliser $\text{Aut}(\mathbf{w})$.

The invariant $N^{\text{trop}}(\mathbf{w})$ is the number of rational tropical curves $\Gamma \rightarrow \mathbb{R}^2$ with ‘‘boundary conditions’’ (weighted legs) \mathbf{w} . Namely fix general, parallel horizontal lines $\{\mathfrak{d}_{1j}\}$ and vertical lines $\{\mathfrak{d}_{2j}\}$. Then Γ is a tree with unbounded edges E_{ij} mapping to a fixed line \mathfrak{d}_{ij} , the weight is $w(E_{ij}) = w_{ij}$, and so in our case there is a single outgoing ray in the direction of (a, b) (we emphasise that there are as many roots in Γ as parts of \mathbf{w}). This is well defined and independent of the choice of lines ([GPS] Section 2.3).

Remark. At least when $w(E_{ij}) = 1$ we could introduce stop points along the incoming legs of the tropical curve which would then correspond to boundary components lying on the Lagrangian fibres of the moment map. This justifies somewhat the terminology ‘‘boundary conditions’’.

We should mention that the formula (1.3) arises in [GPS] as the combination of a degeneration formula and two equivalences, with holomorphic and tropical counts respectively. First one performs degeneration to the normal cone of $D_1 \cup D_2 \cup D_{\text{out}}$ with a suitable set of sections blown-up. This gives

(1.3) with relative GW invariants $N_{a,b}^{\text{rel}}(\mathbf{w}) \prod_{i,j} w_{ij}$ in place of the tropical counts $N^{\text{trop}}(\mathbf{w})$. The first equivalence is then with holomorphic counts,

$$N_{a,b}^{\text{rel}}(\mathbf{w}) = N_{a,b}^{\text{hol}}(\mathbf{w}),$$

proved in [GPS] Theorem 4.4. The right hand side is a theory of maps $\mathbb{P}^1 \rightarrow X_{a,b}^o$ which touch D_i at l_i points with orders $w_{ij}, j = 1, \dots, l_i$ (respectively D_{out} with order $\text{ind}(\mathbf{w})$). The second equivalence is with tropical counts,

$$N_{a,b}^{\text{hol}}(\mathbf{w}) \prod_{i,j} w_{ij} = N^{\text{trop}}(\mathbf{w}),$$

proved in [GPS] Theorem 3.4.

The advantage of the physical point of view of the previous section is that it suggests an analogy between the formulae (1.2) and (1.3), i.e. in both cases we are computing our invariants (Witten indexes) by summing up over all boundary conditions (in other words it allows us to regard $[\tilde{d}]$ as specifying boundary conditions for open strings, while \mathbf{w} specifies “boundary conditions” for tropical curves).

The upshot of our discussion is that the GW/Kronecker correspondence should arise from a family of identities which relate \mathbf{w} to \tilde{d} .

Fix a finite subquiver $Q \subset \widetilde{K(m)}$, and order the vertices so that sinks come before sources. Choose a weight vector $\mathbf{w}' = (\mathbf{w}'_1, \dots, \mathbf{w}'_{|Q_0|})$ and let $s = \#\{\text{sinks}\}$ and $S = \#\{\text{sources}\}$. We write

$$x^{\mathbf{w}'} := x_1^{|\mathbf{w}'_1|} \dots x_{s+S}^{|\mathbf{w}'_{s+S}|}.$$

Notice that \mathbf{w}' can be “flattened” to the weight vector $\mathbf{w} = (\mathbf{w}_1, \mathbf{w}_2)$ with

$$\begin{aligned} \mathbf{w}_1 &= ((w'_{(s+1)j})_{j=1}^{l_{s+1}}, (w'_{(s+2)j})_{j=1}^{l_{s+2}}, \dots, (w'_{(s+S)j})_{j=1}^{l_{s+S}}), \\ \mathbf{w}_2 &= ((w'_{1j})_{j=1}^{l_1}, (w'_{2j})_{j=1}^{l_2}, \dots, (w'_{sj})_{j=1}^{l_s}). \end{aligned}$$

We can further reduce to a dimension vector $\bar{\mathbf{w}} = (\sum_{i>s} |\mathbf{w}'_i|, \sum_{i \leq s} |\mathbf{w}'_i|)$, and then we define $\mu(\mathbf{w}') = \mu(\bar{\mathbf{w}})$. Similarly \tilde{d} can be reduced to a dimension vector d for $K(m)$, and we write $(\mathbb{N}Q_0)_\mu$ for the subsemigroup of dimension vectors whose reduction has slope μ .

The identities we will find have the form

$$\exp \left(\sum_{\mathbf{w}' | \mu(\mathbf{w}') = \mu} \frac{\langle i_{\bar{p}}, \mathbf{w}' \rangle N_Q^{\text{trop}}(\mathbf{w}')}{|\text{Aut}(\mathbf{w}')|} R_{\mathbf{w}'} x^{\mathbf{w}'} \right) = \sum_{\tilde{d} \in (\mathbb{N}Q_0)_\mu} \chi(\mathcal{M}_{Q, i_p}(\tilde{d})) x^{\tilde{d}}, \quad (1.4)$$

where $\mu = \frac{a}{a+b}$ and we fixed a reference point i_p for the framing (such that it maps to a suitable sink $i_{\bar{p}}$). The coefficients $\langle i_{\bar{p}}, \mathbf{w}' \rangle, N_Q^{\text{trop}}(\mathbf{w}'), R_{\mathbf{w}'}$ are

to be determined. The number $N_Q^{\text{trop}}(\mathbf{w}')$ will have a geometric meaning as the contribution of Q to $N^{\text{trop}}(\mathbf{w})$.

The correspondence (1.1) is then recovered in the limit as Q becomes larger,

$$\begin{aligned}
& \exp \left(\frac{a}{m} \sum_{k \geq 1} \sum_{|P_a|=ka, |P_b|=kb} k N_{a,b}[(P_a, P_b)] x^{ka} y^{kb} \right) \\
&= \lim_{\rightarrow Q} \exp \left(\sum_{\mathbf{w}' | \mu(\mathbf{w}') = \mu} \frac{\langle i_{\bar{p}}, \mathbf{w}' \rangle N_Q^{\text{trop}}(\mathbf{w}')}{|\text{Aut}(\mathbf{w}')|} R_{\mathbf{w}'} x^{\bar{w}} \right) \\
&= \lim_{\rightarrow Q} \sum_{\tilde{d} \in (\mathbb{N}Q_0)_\mu} \chi(\mathcal{M}_{Q, i_p}(\tilde{d})) x^{\tilde{d}} \\
&= 1 + \sum_{k \geq 1} \chi(\mathcal{M}_m^{(1,0),B}(ka, kb)) x^{ka} y^{kb} \tag{1.5}
\end{aligned}$$

(we fix a representative for the $W(K(m))$ action by moving the framing to the reference point).

Acknowledgements. This is an application of some of the ideas in [GPS] and [Re]. It was motivated by conversations with So Okada and Thorsten Weist, and I take this opportunity to thank them. I am also grateful to Hiraku Nakajima, Markus Reineke and Richard Thomas, as well as to RIMS, Kyoto and Trinity College, Cambridge.

2. THE FORMULAE (1.4) AND (1.5)

2.1. Notation. In this section we discuss the formulae (1.4) and (1.5). We start by fixing a finite subquiver $Q \subset \widetilde{K(m)}$, the infinite m -regular graph with an orientation. We denote by Q_0 the set of vertices and by Q_1 the set of arrows. The lattice of dimension vectors of Q is generated by the vertices. We label the sinks by i_1, \dots, i_s , the sources by i_{s+1}, \dots, i_{s+S} (so there are s sinks and S sources). Notice that in particular Q has no oriented (or indeed unoriented) cycles, so we can follow Reineke's convention and fix an order such that $i_k \rightarrow i_l \Rightarrow k > l$. For our purposes we also need that the order is minimal, in the sense that for $k = 1, \dots, s$ the sinks mapping to i_k have the smallest possible labels.

We denote by $e(\bullet, \bullet)$ the Euler form of Q . The skew-symmetrised Euler form $\langle i_k, i_l \rangle$ (the DSZ product in this context) equals 0 or ± 1 (a possible source of confusion is that this is usually denoted by $\{\bullet, \bullet\}$ in Reineke's notation, while $\langle \bullet, \bullet \rangle$ denotes the Euler form which is *not* skew-symmetric in general). Recall that a representation of $Q \subset \widetilde{K(m)}$ (the infinite oriented m -regular graph) plus an admissible (equivalence class of) colouring of the

arrows by $\{1, \dots, m\}$ gives back a unique representation for $K(m)$ (this would not be true for $\widehat{K(m)}$, because of possible unoriented closed cycles, e.g. for the hexagonal quiver $\widehat{K(3)}$).

There is a Poisson algebra modelled on Q ,

$$\mathcal{B} = (\mathbb{C}[[x_k]]_{k=1, \dots, s+S}, \langle \bullet, \bullet \rangle),$$

with Poisson bracket generated by $\langle x_k, x_l \rangle = \langle i_k, i_l \rangle x_k x_l$. For any dimension vector $d \in \mathbb{N}Q_0$ the Kontsevich-Soibelman Poisson automorphism $T_d \in \text{Aut}(\mathcal{B})$ (a version of the operators appearing in [KS] Section 1.4) is defined by

$$T_d(x_k) = x_k(1 + x^d)^{\langle d, i_k \rangle}.$$

The slope of dimension vectors is induced from $K(m)$, namely

$$\mu(d) = \frac{\sum_{k>s} d_k}{\sum_k d_k}. \quad (2.1)$$

The set of dimension vectors with slope μ forms a subsemigroup $(\mathbb{N}Q_0)_\mu \subset \mathbb{N}Q_0$. A dimension vector d has a reduction $\bar{d} \in \mathbb{N}K(m)_0 \cong \mathbb{N} \times \mathbb{N}$ given by

$$\bar{d} = \left(\sum_{i>s} d_i, \sum_{i \leq s} d_i \right).$$

The fundamental object for us is the Poisson automorphism of \mathcal{B} given by

$$T_{i_1} \circ T_{i_2} \cdots \circ T_{i_s} \circ T_{i_{s+1}} \circ \cdots \circ T_{i_{s+S}}. \quad (2.2)$$

By the general theory this can be written as a product of Poisson automorphisms attached to each rational nonnegative slope, $\prod_{\mu}^{\leftarrow} \theta_{Q, \mu}$. The symbol \leftarrow means we are writing factors in this product in the *descending* slope order from left to right.

Reineke's theorem ([Re] Theorem 2.1) expresses $\theta_{Q, \mu}$ in terms of the Euler characteristics of moduli spaces of stable framed representations of Q :

$$\theta_{Q, \mu}(x_j) = x_j \prod_{i \in Q_0} (\theta_{Q, \mu, i})^{\langle i, j \rangle}, \quad (2.3)$$

where

$$\theta_{Q, \mu, i} = \sum_{d \in (\mathbb{N}Q_0)_\mu} \chi(\mathcal{M}_{Q, i}(d)) x^d \quad (2.4)$$

and $\mathcal{M}_{Q, i}(d)$ is the moduli space of stable representations of Q (with respect to the choice of slope (2.1)) with a 1-dimensional framing at $i \in Q_0$.

What is missing is how to write the slope ordered product $\prod_{\mu}^{\leftarrow} \theta_{Q, \mu}$ in terms of curves. To see how curves enter the picture we will try to factor the product (2.2) in the opposite slope order, by naively sorting one element at a time through the ordered product.

Remark. The reason why the procedure we now describe converges to the correct ordered product factorisation $\prod_{\mu}^{\leftarrow} \theta_{Q,\mu}$ is that it can be seen as a sequence of Kontsevich-Soibelman wall-crossings converging to the single wall-crossing from the central charge for Z_- induced from $(0, 1)$ to the one of interest, Z_+ , induced from $(1, 0)$.

2.2. The standard Kronecker quiver. To illustrate the point we focus on the simplest example, the localisation quiver Q for $K(2)$ given by

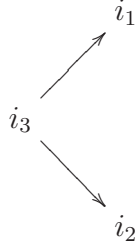

(notice that $\widehat{K(m)} = \widetilde{K(m)}$ if and only if $m = 2$). Its contribution to the generating function for B -framed Euler characteristics of $K(2)$ with dimension vector proportional to $(1, 2)$ is xy^2 . Of course $\mathcal{M}_{\widehat{K(2)}}(1, 2)$ is just a point, so $\chi(\mathcal{M}_{\widehat{K(2)}}(1, 2)) = 1$. On the other hand let us consider the product $T_{i_1} \circ T_{i_2} \circ T_{i_3}$. The first step, sorting T_{i_2} , gives

$$T_{i_1} T_{i_2} T_{i_3} = T_{i_1} T_{i_3} [T_{i_2}, T_{i_3}] T_{i_2},$$

It is easy to compute such commutators.

Lemma 2.5. *If $\langle d, e \rangle = 0$ then $[T_d, T_e] = 0$; and if $\langle d, e \rangle = 1$ then $[T_d, T_e] = T_{d+e}$.*

Proof. Both equalities can be checked by direct computation, the second is the “pentagon identity” [KS] Section 1.4. \square

So we can continue to sort, finding

$$\begin{aligned} T_{i_1} T_{i_2} T_{i_3} &= T_{i_1} T_{i_3} T_{i_2+i_3} T_{i_2} \\ &= T_{i_3} T_{i_1+i_3} T_{i_1} T_{i_2+i_3} T_{i_2} \\ &= T_{i_3} T_{i_1+i_3} T_{i_2+i_3} T_{i_1+i_2+i_3} T_{i_1} T_{i_2}. \end{aligned} \tag{2.6}$$

Thus the unique full dimension vector here is $i_1 + i_2 + i_3$. We picture the sorting process by the tree

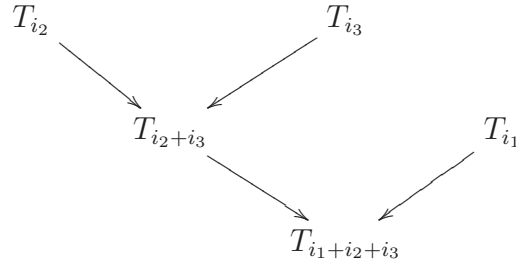

With this tree we can associate a tropical curve in \mathbb{R}^2 (pictured on the right hand side of Figure 2), with legs labelled by i_1, i_2, i_3 ; this produces a weight function f modelled on [GPS] Lemma 1.9 (the precise definition will be given in the next section), easily computed as $f = 1 + x_1x_2x_3$.

In general for $d \in \mathbb{N}Q_0$ and $f = 1 + p(x), p(x) \in x^d \mathbb{C}[[x^d]]$, we write $\theta_{d,f}$ for the Poisson automorphism given by

$$\theta_{d,f}(x_i) = x_i f(x^d)^{\langle i, d \rangle}. \quad (2.7)$$

The Poisson automorphisms $\theta_{Q,\mu}$ can be computed alternatively as a composition of $\theta_{d,f}$. In our special case comparing with Reineke's theorem gives

$$\theta_{Q, \frac{1}{3}, i_3} = \theta_{i_1+i_2+i_3, 1+x_1x_2x_3}.$$

The more general functions f have a reduction \bar{f} by the change of variables

$$x_1 \mapsto y, \dots, x_s \mapsto y; \quad x_{s+1} \mapsto x, \dots, x_{s+S} \mapsto x. \quad (2.8)$$

This reduction \bar{f} determines the contribution to framed Euler characteristics of $K(2)$. We wish to compute $\bar{f} - 1$ for the various functions f arising from diagrams in $\widetilde{K(2)}$. For our current example (2.2) this is simple, we get the same as the contribution of the unique point in quiver moduli, xy^2 , so the basic picture becomes Figure 2.

Let us work out more examples for $m = 2$. The only semistable dimension vectors are multiples of $(k, k+1)$ or $(k+1, k)$. Let us focus on $(k, k+1)$. The moduli of B -framed representations is \mathbb{P}^{k-1} . We have contributions given by all torus fixed framings of the unique stable representation of $\widetilde{K(2)}$ of dimension vector $(k, k+1)$, corresponding to the weight function attached to a single tropical curve with $k+1$ vertical legs and k horizontal legs. This weight function is computed as above using the DSZ product on $\mathbb{N}Q_0$, with a formula modelled on [GPS] Lemma 1.9. As an example the dimension vector $i_1 + i_2 + i_3 + i_4 + i_5$ corresponds to the sorting diagram

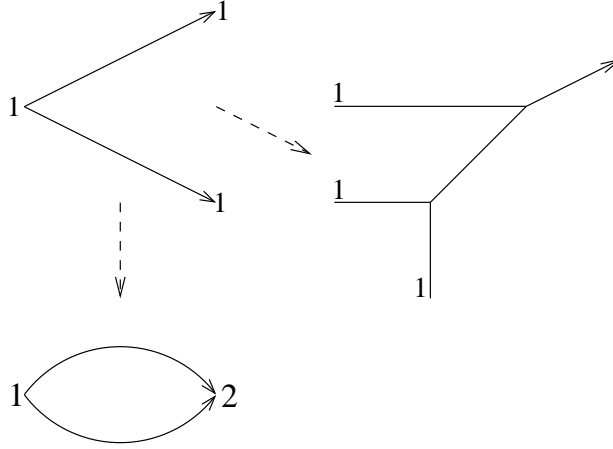
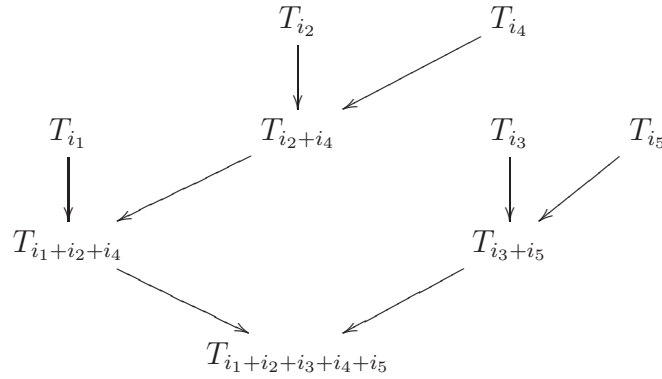

FIGURE 2. From a framed representation to a tropical curve.



which maps to the tropical curve depicted in Figure 3. In general, for the dimension vector

$$d = i_1 + \cdots + i_s + i_{s+1} + \cdots + i_S$$

($\bar{d} = (k, k+1)$), the tropical curve we find is given by adjoining to the curve for $(k-1, k)$ the elementary curve “ W ” depicted in Figure 4.

Remark. The representations for $d = i_1 + \cdots + i_s + i_{s+1} + \cdots + i_S$ can be obtained by gluing copies of $d' = i_1 + i_2 + i_3$ using Weist’s construction [We] Corollary 5.28. The analogue of this for curves is adjoining the elementary curve “ W ” as done in Figure 3.

The weight function is given by $1 + \prod_{l=1}^{2k+1} x_l$. For $k+2 \leq r \leq 2k+1$ we have

$$\theta_{Q, \frac{k}{2k+1}, i_r} = \theta_{\sum_{l=1}^{2k+1} i_l, 1 + \prod_{l=1}^{2k+1} x_l},$$

so the total contribution to framed Euler characteristics of $K(2)$ is $k(\bar{f}-1) = kx^k y^{k+1}$ as expected.

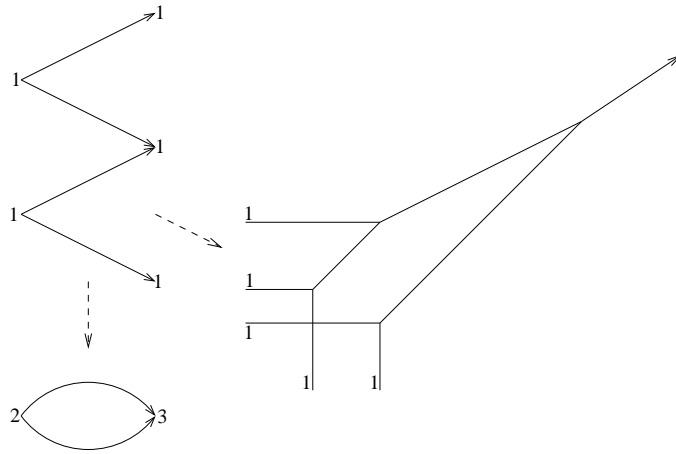

FIGURE 3. From a framed representation to a tropical curve, a more complicated example (“dyon”).

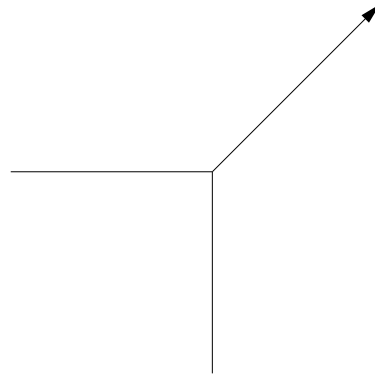

FIGURE 4. Elementary tropical curve (“W”).

Next, suppose we wish to compute the tropical curve of the representation of $\widehat{K(2)}$ given by k sources and $k + 1$ sinks, with dimension vector

$$d = i_1 + 2i_2 + \cdots + 2i_{s-1} + i_s + i_{s+1} + 2i_{s+2} + \cdots + 2i_{S-1} + i_S$$

with reduction $\bar{d} = 2(k - 1, k)$ (so these contribute to the higher order corrections to the generating function for B -framed Euler characteristics of $K(2)$). Notice that the moduli space of representations framed at one of the sources with dimension 2 is just a point (the other framings are empty). This is the first case in which we find a *disconnected* tropical curve as a result (i.e. a map from a disconnected tree). It is simply the union of the tropical curves for the isolated fixed points of dimension vectors

$$d' = i_1 + \cdots + i_{s-1} + i_{s+1} + \cdots + i_{S-1}$$

and

$$d'' = i_2 + \cdots + i_s + i_{s+2} + \cdots + i_S.$$

(see Figure 5 for the curve corresponding to $i_1 + 2i_2 + 2i_3 + i_4 + i_5 + 2i_6 + i_7$).

The weight function is given by

$$f = (1 + x_1 \cdots x_{s-1} x_{s+1} \cdots x_{S-1})(1 + x_2 \cdots x_s x_{s+2} \cdots x_S);$$

its contribution is therefore $(k-2)x^{2k-2}y^{2k}$, which is the same as that of the (framings of the) given representation.

We only get disconnected curves when superimposing representations of the same slope, so the outgoing rays will always be parallel.

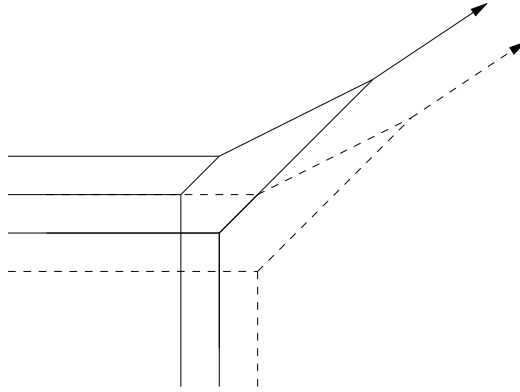

FIGURE 5. Disconnected tropical curves (with parallel outgoing rays) may arise.

In general, following the procedure described above one can construct a (possibly disconnected) tropical curve starting with a representation of $\widehat{K(2)}$.

The reason why things work well for the standard Kronecker quiver is that here the localisation quivers, i.e. finite subquivers of $\widehat{K(2)}$, have a finite spectrum, that is only finitely many stable dimension vectors. To see this notice that in the quadric $1 - e(d, d)$ on $\mathbb{N}\widehat{K(m)}_0$ (which gives the dimension of the space of semistable representations) the quadratic term $e(d, d)$ is always positive definite for $m = 2$. It follows that in sorting the product (2.2) for a subquiver of $\widehat{K(2)}$ the only possible values for the DSZ product $\langle \bullet, \bullet \rangle$ are 0 and 1, since all other possible DSZ products would contribute an infinite spectrum (see [KS] Section 1.4).

We are not so lucky for $m \geq 3$. This is related to the appearance of a dense component in the spectrum for products $T_{1,0}^m \circ T_{0,1}^m$ for $m \geq 3$ (see

e.g. [GP] Figure 1.3). From our current point of view the problem is that in sorting the product (2.2) for a finite subquiver of $\widetilde{K(m)}$ for $m \geq 3$ we may first hit a DSZ product with value -1 at some point. Now $\langle \bullet, \bullet \rangle = -1$ contributes an infinite spectrum, with first few terms

$$\begin{aligned} T_{0,1} \circ T_{1,0} &= \prod_{a,b}^{\rightarrow} T_{a,b}^{\Omega(a,b)} \\ &\approx T_{1,0} \circ T_{3,1}^{-1} \circ T_{2,1} \circ T_{3,2}^2 \circ T_{1,1}^{-1} \circ T_{2,2}^{-2} \circ T_{2,3}^2 \circ T_{1,2} \circ T_{1,3}^{-1} \circ T_{0,1}, \end{aligned}$$

(notice that a closed formula for the $\langle \bullet, \bullet \rangle = -1$ spectrum is unknown at present).

For a concrete example we look at the subquiver of $\widetilde{K(3)}$ given by

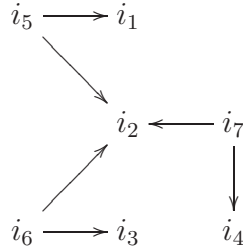

One can check that its quadratic form $e(d, d)$ is only semidefinite, annihilated by $i_1 + 3i_2 + i_3 + i_4 + 2i_5 + 2i_6 + 2i_7$, so the spectrum can be infinite.

This is actually the case: in the sorting tree for the product (2.2) we find after a few iterations a tree containing the segment

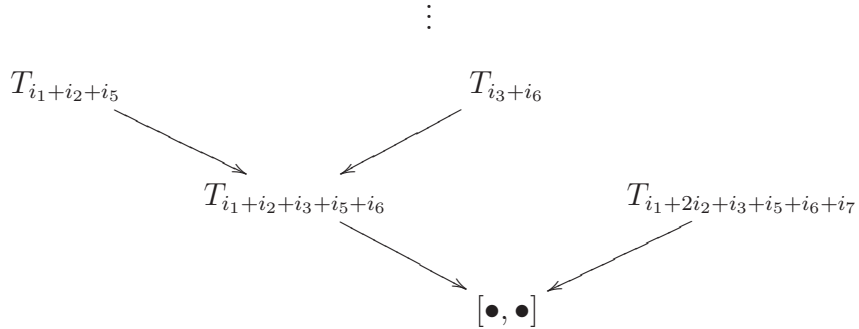

(the commutator of the last two leaves), and we have

$$\langle i_1 + i_2 + i_3 + i_5 + i_6, i_1 + 2i_2 + i_3 + i_5 + i_6 + i_7 \rangle = -1.$$

To remedy this we have to apply the factorisation-deformation technique developed in [GPS] Section 1.4. Doing so however we lose the neat way of constructing a tropical curve from a framed representation which we had for $m = 2$; now each representation will contribute a whole spectrum of

tropical curves, and what we can actually do is finding the contribution of a given localisation quiver Q .

2.3. Factorisation/deformation. Thus for a fixed $k \geq 1$ we consider the product (2.2) over the ring

$$R_k = \mathbb{C}[[t_1, \dots, t_s, t_{s+1}, \dots, t_{s+S}]] / (t_1^{k+1}, \dots, t_s^{k+1}, t_{s+1}^{k+1}, \dots, t_{s+S}^{k+1}),$$

in other words we redefine

$$T_d(x_i) = x_i(1 + t^d x^d)^{\langle d, i \rangle}$$

and work modulo $(t_1^{k+1}, \dots, t_s^{k+1}, t_{s+1}^{k+1}, \dots, t_{s+S}^{k+1})$. Next we separate variables, passing to a version of (2.2) which plays the same role as the “standard scattering diagrams” of [GPS] Definition 1.10. Essentially we need to work over a ring in which the first order approximation

$$T_d \circ T_e \approx T_e \circ T_{d+e}^{(d,e)} \circ T_e$$

becomes *exact*. Following the case of standard scattering diagrams treated in [GPS] this is achieved by considering the ring

$$\tilde{R}_k = \mathbb{C}[\{u_{ij}, 1 \leq i \leq s + S, 1 \leq j \leq k\}] / (u_{ij}^2, 1 \leq i \leq s + S, 1 \leq j \leq k).$$

Remark. When $m \geq 3$ we always need to specify an admissible colouring c (up to natural symmetry) in order to identify a representation of Q with one of $K(m)$. So we should really have separate sets of variables $t_{i,c}$ and $u_{ij,c}$ for each (equivalence class of) colouring. We suppress this in the notation throughout this section, but one must remember to sum up over all c in the final formulae.

There is an inclusion $R_k \hookrightarrow \tilde{R}_k$ induced by

$$t_i \mapsto \sum_{j=1}^k u_{ij}.$$

We now factor each of the operators T_i in (2.2) over \tilde{R}_k . First we have the identity in R_k ,

$$\log(1 + t_i x_i) = \sum_{j=1}^k \frac{(-1)^{j-1}}{j} t_i^j x_i^j.$$

Now in \tilde{R}_k ,

$$t_i^j = \sum_{J \subset \{1, \dots, k\}, \#J=j} j! \prod_{l \in J} u_{il}.$$

Therefore

$$\log(1 + t_i x_i) = \sum_{j=1}^k \sum_{J \subset \{1, \dots, k\}, \#J=j} (-1)^{j-1} (j-1)! \prod_{l \in J} u_{il} x_i^j,$$

and since the variables u_{il} are 2-nilpotent,

$$\begin{aligned} 1 + t_i x_i &= 1 + \left(\sum_{l=1}^k u_{il} \right) x_i \\ &= \prod_{j=1}^k \prod_{J \subset \{1, \dots, k\}, \#J=j} \left(1 + (-1)^{j-1} (j-1)! \prod_{l \in J} u_{il} x_i^j \right). \end{aligned}$$

This leads to the factorisation

$$T_i \equiv \prod_{J \subset \{1, \dots, k\}} T_{i,J} \pmod{(t_1^{k+1}, \dots, t_{s+S}^{k+1})}, \quad (2.9)$$

where $T_{i,J} = \theta_{i,f_{i,J}}$ with

$$f_{i,J} = 1 + (-1)^{(\#J)!-1} ((\#J)! - 1)! \prod_{l \in J} u_{il} x_i^{(\#J)!}. \quad (2.10)$$

Notice that $[T_{i,J}, T_{i,J'}] = 0$ so $\prod_J T_{i,J}$ is well defined.

More generally for any subset

$$I \subset \{1, \dots, s+S\} \times \{1, \dots, k\}$$

we introduce the notation

$$u_I = \prod_{(i,j) \in I} u_{ij}.$$

We need the following lemma, an analogue of [GPS] Lemma 1.9.

Lemma 2.11. *Let d_1, d_2 be dimension vectors. Consider the weight functions*

$$\begin{aligned} f_1 &= 1 + c_1 t_1 x^{d_1}, \\ f_2 &= 1 + c_2 t_2 x^{d_2} \end{aligned}$$

for $c_1, c_2 \in \mathbb{C}$. Then over $\mathbb{C}[t_1, t_2]/(t_1^2, t_2^2)$ we have

$$[\theta_{d_1, f_1}, \theta_{d_2, f_2}] = \theta_{d_1 + d_2, g}$$

with

$$g = 1 + c_1 c_2 \langle d_1, d_2 \rangle t_1 t_2 x^{d_1 + d_2}.$$

Proof. We can make the following identifications

$$\begin{aligned}\theta_{d_1, f_1} &= \exp(c_1 t_1 x^{d_1}), \\ \theta_{d_2, f_2} &= \exp(c_2 t_2 x^{d_2}),\end{aligned}$$

with group elements acting by conjugation (see [KS] Section 1.4). Using that t_1, t_2 are 2-nilpotent we find

$$\begin{aligned}\theta_{d_1, f_1} \theta_{d_2, f_2} &= \exp\left(c_1 t_1 x^{d_1} + c_2 t_2 x^{d_2} + \frac{1}{2} \langle c_1 t_1 x^{d_1}, c_2 t_2 x^{d_2} \rangle\right) \\ &= \exp\left(c_1 t_1 x^{d_1} + c_2 t_2 x^{d_2} + \frac{1}{2} c_1 c_2 \langle d_1, d_2 \rangle t_1 t_2 x^{d_1+d_2}\right) \\ &= \exp\left(c_1 t_1 x^{d_1} + c_2 t_2 x^{d_2}\right) \exp\left(\frac{1}{2} c_1 c_2 \langle d_1, d_2 \rangle t_1 t_2 x^{d_1+d_2}\right)\end{aligned}$$

Similarly,

$$\theta_{d_2, f_2} \theta_{d_1, f_1} = \exp\left(c_1 t_1 x^{d_1} + c_2 t_2 x^{d_2}\right) \exp\left(-\frac{1}{2} c_1 c_2 \langle d_1, d_2 \rangle t_1 t_2 x^{d_1+d_2}\right)$$

and the result follows. \square

Corollary 2.12. *Over the coefficient ring \tilde{R}_k , consider the weight functions*

$$\begin{aligned}f_1 &= 1 + c_1 u_{I_1} x^{d_1}, \\ f_2 &= 1 + c_2 u_{I_2} x^{d_2}\end{aligned}$$

for c_i, d_i as above. Then

$$[\theta_{d_1, f_1}, \theta_{d_2, f_2}] = \theta_{d_1+d_2, g}$$

with

$$g = 1 + c_1 c_2 \langle d_1, d_2 \rangle u_{I_1 \cup I_2} x^{d_1+d_2}.$$

So we recast the product (2.2) over \tilde{R}_k , or rather we introduce the sequence

$$\mathfrak{S}_k^0 := \left\{ \prod_{J_1 \subset \{1, \dots, k\}} T_{i_1, J_1}, \dots, \prod_{J_S \subset \{1, \dots, k\}} T_{i_S, J_S} \right\}, \quad (2.13)$$

which we regard as a finite approximation to

$$\mathfrak{S}_\infty := T_{i_1} \circ T_{i_2} \cdots \circ T_{i_s} \circ T_{i_{s+1}} \circ \cdots \circ T_{i_{s+S}}$$

since over $\mathbb{C}[[t_i]]$ we have $\lim_{k \rightarrow \infty} \prod \mathfrak{S}_k^0 = \mathfrak{S}_\infty$.

Now parallel to the scattering diagrams $\mathfrak{D}_k^i, i \geq 0$ of [GPS] Section 1, we have instead sorting diagrams $\mathfrak{S}_k^i, i \geq 0$. These are simply sequences of group elements,

$$\mathfrak{S}_k^i = \{\sigma_{k,1}^i, \dots, \sigma_{k,l_i,k}^i\}.$$

Let us describe the procedure for going from \mathfrak{S}_k^{i-1} to \mathfrak{S}_k^i . The sequence \mathfrak{S}_k^{i-1} contains on the left a certain segment of group elements of the same

slope; we pick the rightmost of these (say $\sigma_{k,p}^i$) and keep commuting it past elements to its right until we meet an element with smaller slope,

$$\mu(\sigma_{k,p}^i) \geq \mu(\sigma_{k,q}^i).$$

The rule for commuting elements is given by Corollary 2.12, so each element $\sigma_{k,l}^i$ is of the form $\theta_{d_{k,l}^i, f_{k,l}^i}$ with

$$f_{k,l}^i = 1 + c_{k,l}^i u_{I_{k,l}^i} x^{d_{k,l}^i}. \quad (2.14)$$

Going from \mathfrak{S}_k^{i-1} to \mathfrak{S}_k^i , all the new elements which appear have strictly larger sets $I_{k,l}^i$. Since $u_{I_1 \cup I_2} = 0$ if $I_1 \cap I_2 \neq \emptyset$, we see that the \mathfrak{S}_k^i stabilise for $i > (s + S)k$.

We now associate a weighted tree Γ_σ with each element $\sigma \in \mathfrak{S}_k^i$. For this, if σ arises as the commutator of $\sigma_1, \sigma_2 \in \mathfrak{S}_k^{i-1}$, we define

$$\text{Parents}(\sigma) = \{\sigma_1, \sigma_2\}.$$

We then have the recursive set-valued functions

$$\text{Ancestors}(\sigma) = \{\sigma\} \cup \bigcup_{\sigma' \in \text{Parents}(\sigma)} \text{Ancestors}(\sigma')$$

and

$$\text{Leaves}(\sigma) = \{\sigma' \in \text{Ancestors}(\sigma) : \sigma' \in \mathfrak{S}_k^0\}.$$

If $\sigma' \in \text{Ancestors}(\sigma) \setminus (\{\sigma\} \cup \mathfrak{S}_k^i)$, then σ' is parent to a unique element of $\text{Ancestors}(\sigma)$; we denote this by $\text{Child}(\sigma')$. Now given $\sigma \in \mathfrak{S}_k^i$, we define the set of vertices

$$\Gamma_\sigma^{[0]} = \{V_{\sigma'} : \sigma' \in \text{Ancestors}(\sigma) \text{ and } \sigma' \notin \mathfrak{S}_k^0\},$$

and the set of edges

$$\Gamma_\sigma^{[1]} = \{E_{\sigma'} : \sigma' \in \text{Ancestors}(\sigma)\}.$$

We define the vertices of $E_{\sigma'}$ as follows. If $\sigma' \notin \{\sigma\} \cup \mathfrak{S}_k^i$ and $\mu(\sigma') \neq \mu(\sigma)$ then

$$\partial(E_{\sigma'}) = \{V_{\sigma'}, V_{\text{Child}(\sigma')}\};$$

if $\sigma' = \sigma$ or more generally $\mu(\sigma') = \mu(\sigma)$ then

$$\partial(E_{\sigma'}) = \{V_\sigma, +\infty\};$$

if $\sigma' \in \mathfrak{S}_k^0$ then

$$\partial(E_{\sigma'}) = \{V_{\text{Child}(\sigma')}, -\infty\}.$$

Notice that if the slope of σ equals that of its parents σ_1, σ_2 then the resulting graph Γ_σ is simply the disjoint union of Γ_{σ_1} and Γ_{σ_2} .

The weight of an edge is defined as follows: we know $\sigma' \in \text{Ancestors}(\sigma)$ is a group element of the form $\theta_{d_{k,l}^i, f_{k,l}^i}$ with $f_{k,l}^i$ given in (2.14), and we set

$$w_{\Gamma_\sigma}(E_{\sigma'}) = \text{ind}(\bar{d}_{k,l}^i). \quad (2.15)$$

We now go from the graph Γ_σ to a tropical curve h_σ . For fixed Q and k , we pick $(2^k - 1)s$ horizontal lines $\mathfrak{d}_{I,i}^y$ and $(2^k - 1)S$ vertical lines $\mathfrak{d}_{J,j}^x$ in \mathbb{R}^2 , labelled by nonempty parts of $\{1, \dots, k\}$ and elements of Q_0 , $i \in \{i_1, \dots, i_s\}$, $j \in \{i_{s+1}, \dots, i_S\}$. We label both vertical and horizontal lines so that they are ordered lexicographically with respect to the fixed admissible order of Q_0 (e.g. the horizontal line $\mathfrak{d}_{\{1\},i_1}^y$ appears on top of all others, and the vertical line $\mathfrak{d}_{\{1,\dots,k\},i_S}^x$ appears to the right of all others). Once we fix this choice, there is a unique equivalence class of parametrised tropical maps from Γ_σ to \mathbb{R}^2 such that the leaves of Γ_σ are identified with the respective half-lines inside the lines we picked. We denote this tropical curve by h_σ . So for fixed Q and k we get a well-defined class of tropical curves

$$\mathcal{S}_{Q,k} = \{h_\sigma : \sigma \in \cup_i \mathfrak{S}_k^i, 0 \leq i \leq k(s+S)\}.$$

Notice that the elements of \mathfrak{S}_k^0 can be labelled by $\sigma_{i,J}^0$ for $i \in Q_0$ and $J \subset \{1, \dots, k\}$.

Recall that the multiplicity of a rational tropical curve $h : \Gamma \rightarrow \mathbb{R}^2$ at a trivalent vertex V is given by

$$\text{Mult}_V(h) = w_1 w_2 |m_1 \wedge m_2|$$

for incoming primitive directions m_1, m_2 with weights w_1, w_2 , and one defines

$$\text{Mult}(h) = \prod_V \text{Mult}_V(h).$$

We set

$$\delta_{ij} = \frac{\langle d_i, d_j \rangle}{|\bar{d}_i \wedge \bar{d}_j|}. \quad (2.16)$$

We define the multiplicity with respect to Q by

$$\text{Mult}_Q(h_\sigma) = \frac{1}{2^{\#\{\text{outgoing rays}\}-1}} \text{Mult}(h_\sigma) \prod_{i,j} \delta_{ij}, \quad (2.17)$$

where i, j range over all the parents in Γ_σ .

Thus the factor δ_{ij} in $\text{Mult}_Q(h)$ should be seen as the density of multiplicity at the vertex V where i, j intersect, as detected by the quiver Q . As an example for the simple localisation quiver of $K(2)$ appearing in Figure 2 we have $\delta_{ij} = 1$.

Notice that the tropical curves we constructed may have a number of *parallel* outgoing rays. The factor $2^{1-\#\{\text{outgoing rays}\}}$ comes from the factor $\frac{1}{2}$ in the approximation

$$\log(T_d T_e) = x^d + x^e + \frac{1}{2} \langle d, e \rangle x^{d+e} + \dots \quad (2.18)$$

which becomes *exact* over \widetilde{R}_k .

By repeatedly using Corollary 2.12 we associate a weight function f_σ with a given curve $h_\sigma \in \mathcal{S}_{Q,k}$,

$$f_\sigma = 1 + \text{Mult}_Q(h) \prod_{i,J} \left(\frac{(-1)^{(\#J)^{-1}}}{\#J} ((\#J)! - 1)! \prod_{l \in J} u_{il} \right) x^{d_{\text{out}}}, \quad (2.19)$$

where the sum is over all $i \in Q_0$ and $J \subset \{1, \dots, k\}$ for which $\sigma_{iJ}^0 \in \text{Leaves}(\sigma)$, and

$$d_{\text{out}} = \sum_{i,J} (\#J) \cdot i.$$

Let $i_{\bar{p}}$ (for some $1 \leq \bar{p} \leq s$) be a sink of Q with precisely one source mapping to it, say i_p ($s+1 \leq p \leq s+S$), which we can move to our reference point. Then in Reineke's theorem we find

$$\theta_\mu(x_{\bar{p}}) = x_{\bar{p}} \cdot \theta_{Q,\mu,p}^{-1}(x).$$

In general, of course, not all sources of Q map to such a sink. What we have to do in that case is increasing the parameter m to $m+1$, adding a single sink from our reference point. This entails introducing an extra variable $x_{\bar{p}}$. We can then compute on this larger quiver, and recover the result we need by setting $x_{\bar{p}} = 0$ in the weight functions we get. Thus the general case is only notationally heavier. Since we are mostly interested in the large Q limit, we omit the details.

We can now run an argument very similar to [GPS] Theorem 2.8. First, thanks to the exactness of the approximation 2.18 over \widetilde{R}_k , we have modulo $(t_1^{k+1}, \dots, t_s^{k+1}, t_{s+1}^{k+1}, \dots, t_{s+S}^{k+1})$

$$\theta_\mu(x_{\bar{p}}) = x_{\bar{p}} \cdot f|_{t_1, \dots, t_{s+S}=1}$$

with

$$\log f = \sum_{\sigma \in \mathcal{S}_{Q,k}(\mu)} \langle d_{\text{out}}(\sigma), i_{\bar{p}} \rangle \log f_\sigma$$

where $\mathcal{S}_{Q,k}(\mu)$ denotes the curves in $\mathcal{S}_{Q,k}$ with $\mu(d_{\text{out}}(\sigma)) = \mu$. Let us fix a curve $\sigma \in \mathcal{S}_{Q,k}(\mu)$. We find a weight vector

$$\mathbf{w}(\sigma) = (\mathbf{w}_1(\sigma), \dots, \mathbf{w}_{s+S}(\sigma)),$$

$$\mathbf{w}_i = w_{i1}(\sigma) + \dots + w_{il_1}(\sigma),$$

and pairwise disjoint sets

$$J_{ij}(\sigma) \subset \{1, \dots, k\}, i = 1, \dots, s+S; j = 1, \dots, l_i,$$

with

$$\#J_{ij} = w_{ij},$$

such that

$$h(\text{Leaves}(\sigma)) = \{\mathfrak{d}_{J_{ij}(\sigma)w_{ij}(\sigma)}^i \mid i = 1, 2; j = 1, \dots, l_i\}.$$

We can rewrite (2.19) in the form

$$\log f_\sigma = \text{Mult}_Q(\sigma) \prod_{i=1}^{s+S} \prod_{j=1}^{l_i} \left(\frac{(-1)^{w_{ij}-1}}{w_{ij}} (w_{ij} - 1)! \prod_{r \in J_{ij}} u_{ir} \right) \mathbf{x}^{\mathbf{w}}.$$

Summing over all curves σ which give rise to the same weight vector \mathbf{w} and the same sets J_{ij} we find a contribution to $\log f$ given by

$$\langle i_{\bar{p}}, \mathbf{w} \rangle N_Q^{\text{trop}}(\mathbf{w}) \prod_{i=1}^{s+S} \prod_{j=1}^{l_i} \left(\frac{(-1)^{w_{ij}-1}}{w_{ij}} (w_{ij} - 1)! \prod_{r \in J_{ij}} u_{ir} \right) \mathbf{x}^{\mathbf{w}},$$

where $N_Q^{\text{trop}}(\mathbf{w})$ is the number of curves $\sigma \in \mathcal{S}_{Q,k}$ with the same weight vector \mathbf{w} and the same sets J_{ij} , counted with the multiplicity $\text{Mult}_Q(\sigma)$.

The notation is justified since, using Corollary 2.12 and the definition of the sets $\mathcal{S}_{Q,k}$ in terms of sorting diagrams, one can check that the number $N_Q^{\text{trop}}(\mathbf{w})$ only depends on $\#J_{ij}$ (and so \mathbf{w}), not the actual J_{ij} .

Summing up over all J_{ij} would then give

$$\langle i_{\bar{p}}, \mathbf{w} \rangle N_Q^{\text{trop}}(\mathbf{w}) \prod_{i=1}^{s+S} \prod_{j=1}^{l_i} \left(\frac{(-1)^{w_{ij}-1}}{w_{ij}} (w_{ij} - 1)! \right) t^{\mathbf{w}} \mathbf{x}^{\mathbf{w}},$$

but one can show that this overcounts curves by a factor $\prod_{i,j} w_{ij}! |\text{Aut}(\mathbf{w})|$.

Comparing with Reineke's theorem gives

$$\log \theta_{Q,\mu,p}(x) = \sum_{\mathbf{w} \mid \mu(\mathbf{w}) = \mu} \langle i_{\bar{p}}, \mathbf{w} \rangle \frac{N_Q^{\text{trop}}(\mathbf{w})}{|\text{Aut}(\mathbf{w})|} R_{\mathbf{w}} \mathbf{x}^{\mathbf{w}},$$

where the ‘‘ramification’’ correction of a weight vector is

$$R_{\mathbf{w}} = \prod_{i=1}^{s+S} \prod_{j=1}^{l_i} \frac{(-1)^{w_{ij}-1}}{w_{ij}^2}$$

and its slope is

$$\mu(\mathbf{w}) = \mu(\bar{\mathbf{w}}), \quad \bar{\mathbf{w}} := \left(\sum_{i>s} |\mathbf{w}_i|, \sum_{i \leq s} |\mathbf{w}_i| \right).$$

It follows that the contribution of Q to the B -framed Euler characteristics for $K(m)$ coming from the source p can be written as

$$\overline{\theta_{Q,\mu,p}} = \exp \left(\sum_{\mathbf{w}|\mu(\mathbf{w})=\mu} \frac{\langle i_{\bar{p}}, \mathbf{w} \rangle N_Q^{\text{trop}}(\mathbf{w})}{|\text{Aut}(\mathbf{w})|} R_{\mathbf{w}} x^{\bar{\mathbf{w}}} \right). \quad (2.20)$$

REFERENCES

- [De] F. Denef, *Quantum quivers and Hall/hole halos*, J. High Energy Phys. 2002, no. 10, 023, 42 pp.
- [ER] J. Engel and M. Reineke, *Smooth models of quiver moduli*, Math. Z. 262 (2009), no. 4, 817–848.
- [GMN] D. Gaiotto, G. Moore and A. Nietzke, *Four dimensional wall-crossing via three-dimensional field theory*, Comm. Math. Phys. 299 (2010), no. 1, 163–224.
- [GP] M. Gross and R. Pandharipande, *Quivers, curves, and the tropical vertex*, Port. Math. 67 (2010), no. 2, 211259.
- [GPS] M. Gross, R. Pandharipande and B. Siebert, *The tropical vertex*, Duke Math. J. 153 (2010), no. 2, 297362.
- [KS] M. Kontsevich and Y. Soibelman, *Stability structures, motivic Donaldson-Thomas invariants and cluster transformations*, arXiv:0811.2435.
- [Re] M. Reineke, *Poisson automorphisms and quiver moduli*, J. Inst. Math. Jussieu 9 (2010), no. 3, 653667.
- [We] T. Weist, *Localization in quiver moduli spaces*, arXiv:0903.5442.

DEPARTMENT OF PURE MATHEMATICS AND MATHEMATICAL STATISTICS, UNIVERSITY OF CAMBRIDGE, WILBERFORCE ROAD, CAMBRIDGE CB3 0WB, UK
E-mail address: J.Stoppa@dpms.cam.ac.uk