

Model Order Reduction of Linear Time Variant High Speed VLSI Interconnects using Frequency Shift Technique

J.V.R.Ravindra, *Student Member, IEEE*, M.B.Srinivas, *Member, IEEE*

Abstract—Accurate modeling of high speed RLC interconnects has become a necessity to address signal integrity issues in current VLSI design. To accurately model a dispersive system of interconnects at higher frequencies; a full-wave analysis is required. However, conventional circuit simulation of interconnects with full wave models is extremely CPU expensive. We present an algorithm for reducing large VLSI circuits to much smaller ones with similar input-output behavior. A key feature of our method, called Frequency Shift Technique, is that it is capable of reducing linear time-varying systems. This enables it to capture frequency-translation and sampling behavior, important in communication subsystems such as mixers, RF components and switched-capacitor filters. Reduction is obtained by projecting the original system described by linear differential equations into a lower dimension. Experiments have been carried out using Cadence Design Simulator © which indicates that the proposed technique achieves more % reduction with less CPU time than the other model order reduction techniques existing in literature. We also present applications to RF circuit subsystems, obtaining size reductions and evaluation speedups of orders of magnitude with insignificant loss of accuracy.

Keywords—Model order Reduction, RLC, crosstalk

I. INTRODUCTION

THE recent trend in the VLSI industry toward miniature designs, low power consumption, high speed digital circuits and increased integration of analog circuits with digital blocks has made the signal integrity analysis a challenging task. When analyzing high-performance integrated circuit designs, it is well known that the single lumped resistor-capacitor (RC) model of interconnect is insufficiently accurate. It has been shown [1] that reasonably accurate electro-quasistatic, or transient interconnect, simulations could be performed by computing the time evolution of the electric field both inside and outside the conductors via a finite-difference discretization of Laplace's equation. A boundary-element approach [2] based on Green's theorem was proposed which performs the calculation using the same surface discretization used for ordinary capacitance extraction, thereby avoiding the large exterior domain mesh and computation.

To verify the effects induced by interconnects, a combination of extraction and analysis is necessary. Extraction

J.V.R.Ravindra is with the Center for VLSI and Embedded System Technologies (CVEST), International Institute of Information Technology (IIIT), Hyderabad 500 032, Andhra Pradesh, India, Department e-mail: ravindra@iiit.ac.in

M.B.Srinivas is an Assoc.Prof and with the Center for VLSI and Embedded System Technologies (CVEST), International Institute of Information Technology (IIIT), Hyderabad 500 032, Andhra Pradesh, India, Department e-mail: srinivas@iiit.ac.in

determines the resistance, the capacitance and the inductance of interconnects, which can then be used to build a circuit model for the analysis of interconnect effects. For analysis (or simulation), research has been carried out of the use of model order reduction (MOR) [3-5], complex frequency hopping [6-8], krylov-space techniques [9, 10] and multi conductor transmission lines [11-13]. Model order reduction is based on approximating the Laplace-domain transfer function of a linear (or linearized) network by a relatively small number of dominant poles and zeros. Such reduced-order models can be used to predict the time-domain or frequency-domain response of the linear network. A multipoint moment-matching or complex frequency hopping (CFH) technique extracts accurate dominant poles of a linear sub-network up to any predefined maximum frequency. This method generates a single transfer function for a large linear sub-network and provides for a CPU/accuracy tradeoff. Model order reduction can also be obtained using projecting the original system described by nonlinear differential equations into krylov subspace of lower dimension. This reduced model can be simulated using conventional numerical techniques. Simulation of interconnects can also be performed treating the interconnect as full-wave model.

The rest of the paper is organized as follows: MOR techniques of linear circuits are explained in section 2. An introduction to linear time varying systems is given in section 3. Frequency shift technique is stated in section 4 and the problem statement is given in section 5. Simulation results are shown in section 5 while conclusions are made in section 6.

II. MODEL ORDER REDUCTION OF LINEAR CIRCUITS

Model order reduction is a technique that takes a circuit containing a large number of poles and reduces it to a smaller representation consisting of the dominant poles from the original linear circuit as shown in Fig. 1. There are two approaches to model order reduction: moment matching techniques [14-16] and matrix approximation [17].

A lumped linear time-invariant circuit can be described by first-order differential equations

$$\begin{aligned}\dot{x} &= Ax + Bu \\ y &= Cx + Du\end{aligned}\quad (1)$$

where x is an n -dimensional state vector, A is an $n \times n$ matrix, u is the system's input, y is the output of interest, and D denotes the direct coupling matrix. It is desired to obtain the

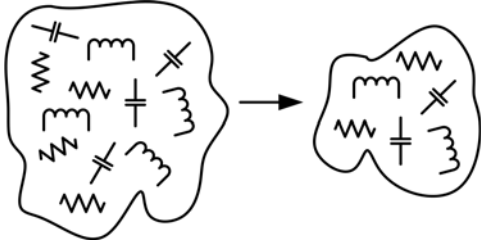

Fig. 1. Model Order Reduction

zero-state impulse response of a linear circuit described by eq. (1), which in turn can be used to determine its response to any excitation. Hence, the Laplace transform is applied to eq. (1) assuming zero initial conditions and for convenience the direct coupling matrix D is neglected. Then, we obtain

$$\begin{aligned} sX &= AX + BU \\ Y &= CX \end{aligned} \quad (2)$$

Where X , Y , and U denote the Laplace transform of x , y , and u respectively. It follows from eq. (2) that the transfer function, or the Laplace transform of the impulse response, defined as $H(s) = Y(s)/U(s)$, is given by

$$H(s) = C(sI - A)^{-1}B \quad (3)$$

Where I is identity matrix. $H(s)$ can be expanded using Maclaurin series

$$H(s) = \sum_{i=0}^{\infty} m_i s^i \quad (4)$$

Comparing eq (3) and (4) and equating like powers of s , it can be shown that

$$m_i = -CA^{-i-1}B, \quad i = 0, 1, 2, \dots \quad (5)$$

In a reduced-order model, especially one obtained by moment matching, the transfer function is approximated by the reduced-order system of proper rational function of s having q -poles

$$H(s) = \frac{n_{q-1}s^{q-1} + n_{q-2}s^{q-2} + \dots + n_1s + n_0}{s^q + d_{q-1}s^{q-1} + \dots + d_1s + d_0} \quad (6)$$

Because there are $2q$ unknowns in the reduced-order system, it is forced to correspond to the first $2q$ terms of eq.(6) by using *Padé* approximation, yielding the following equality:

$$\begin{aligned} \frac{n_{q-1}s^{q-1} + n_{q-2}s^{q-2} + \dots + n_1s + n_0}{s^q + d_{q-1}s^{q-1} + \dots + d_1s + d_0} \\ = m_0 + m_1s + \dots + m_{2q-1}s^{2q-1} \end{aligned} \quad (7)$$

Multiplying both sides of eq. (7) by the denominator of the left-hand side yields a set of equations that can be solved for $2q$ coefficients. After finding roots of the denominator of the reduced-order model, eq. (6) can be expressed as a partial fraction expansion form given by

$$\hat{H}(s) = \sum_{i=1}^q \frac{r_i}{s - p_i} \quad (8)$$

where r_i is a residue of $\hat{H}(s)$ at the pole p_i . It is then straightforward to obtain the approximated impulse response $\hat{h}(t)$ from (8).

III. LINEAR TIME VARYING SYSTEMS

A nonlinear system driven by a large signal $b_L(t)$ and a small signal $u(t)$ can be described by a set of nonlinear differential algebraic equations

$$\begin{aligned} \frac{dq(x(t))}{dt} + f(x(t)) &= b_L(t) + bu(t) \\ z(t) &= d^T x(t) \end{aligned} \quad (9)$$

where $x(t) \in \mathbb{R}^n$ is the vector of node voltages; $q(\cdot)$ and $f(\cdot)$ are nonlinear functions describing the charge/flux and resistive elements, respectively; $z(t)$ is the set of output nodes; b and d are selector vectors that map the input and output ports to the space of the networks, and n is number of nodes in the network. Splitting the response into two parts:

$$x(t) = x_L(t) + x_S(t) \quad (10)$$

where $x_L(t)$ and $x_S(t)$ are the responses due to the large signal $b_L(t)$ and small signal $u(t)$, respectively. Substituting from eq.(10) into eq.(9) and linearizing around $x_L(t)$ yields the LTV system,

$$\frac{d(C(t)x_S(t))}{dt} + G(t)x_S(t) = bu(t) \quad (11)$$

where,

$$G(t) = \left. \frac{\partial f}{\partial x} \right|_{x=x_L(t)} \quad C(t) = \left. \frac{\partial q}{\partial x} \right|_{x=x_L(t)} \quad (12)$$

Zadeh [18] has introduced the concept of time varying system function to describe the response of LTV systems. According to Zadeh's formalism, an LTV system can be characterized by using a time-varying transfer function, $h(s, t)$, where the response of the system due to an input of the form e^{st} is given by $e^{st}h(s, t)$ [12]. Thus, by substituting in eq.(11) we get,

$$\frac{d(C(t)h(s, t))}{dt} + sC(t)h(s, t) + G(t)h(s, t) = b \quad (13)$$

The transfer path from the input to the set of the output nodes can be represented by a time-varying transfer function $\Phi(s, t)$ where,

$$\Phi(s, t) = d^T h(s, t) \quad (14)$$

It is clear from eq. (14) that a full characterization of the system transfer function requires a solution of LTV system for many values of 's'.

IV. FREQUENCY SHIFT TECHNIQUE

Model order reduction is a technique that takes a circuit containing a large number of poles and reduces it to a smaller representation consisting of the dominant poles from the original linear circuit. The generalized dynamic equations of RLC circuit shown in Fig.2 can be written as

$$M\ddot{V}(x, s) + KV(x, s) = F(x, s) \quad (15)$$

$$M\dot{I}(x, s) + KI(x, s) = G(x, s) \quad (16)$$

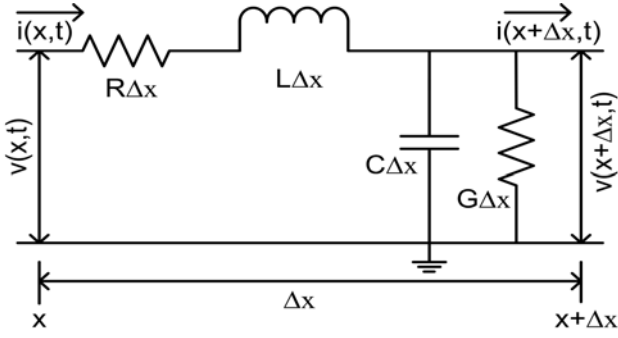

Fig. 2. Cross Section of a Transmission Line

From eq. (15) and eq. (16), $\frac{K}{M} = -\gamma^2$ and $F(x, s)$ and $G(x, s)$ are two different excitations. Solving for $I(x, s)$ from eq. (15) and eq. (16) results

$$I(x, s) = \mathfrak{R}V(x, s) \quad (17)$$

where \mathfrak{R} is called response-dependent condensation matrix. Eq. (17) is called governing equation with frequency shift technique or eigenvalue shift technique [19].

A. Selection of Frequency Shift Value

The frequency shift technique has two functions:

- 1) Accelerating the convergence and
- 2) Making the reduced model close to the original model within any given frequency range.

For the first case, the frequency shift value is

$$0 \leq q < \lambda_1 \quad (18)$$

where the λ_1 is the lowest eigenvalue of the original model. The frequency shift value in the second case can be found as

$$q \approx \frac{\omega_{\min}^2 + \omega_{\max}^2}{2} \quad (19)$$

where ω_{\min} and ω_{\max} are the lower and upper boundary of the frequency range within which the characteristics are required to be kept in the reduced model.

V. PROBLEM STATEMENT

Consider linear circuit which can be described by difference equations as follows:

$$\begin{aligned} x_k &= \mathbb{A}x_{k-1} + \mathbb{B}u_k + v_k \\ y_k &= \mathbb{C}x_{k-1} + \mathbb{D}u_k + w_k \end{aligned} \quad (20)$$

where $k \in \mathbb{Z}$, x is the \mathbb{R}^n real valued state, u is the \mathbb{R}^m -valued observed input, v and w are unobserved input disturbances and y is the \mathbb{R}^q -valued observed output. The main point of this work is that the unobserved input disturbances can be time varying. Hence, rearranging eq.(10)

$$\begin{aligned} x_k &= \mathbb{A}x_{k-1} + \mathbb{B}u_k + \mathbb{M}(k)v_k \\ y_k &= \mathbb{C}x_{k-1} + \mathbb{D}u_k + \mathbb{N}(k)w_k \end{aligned} \quad (21)$$

where

$$\begin{bmatrix} \mathbb{M}(k) \\ \mathbb{N}(k) \end{bmatrix} [\mathbb{M}^T(k) \quad \mathbb{N}^T(k)] \quad (22)$$

is the time-varying covariance matrix, \mathbb{M} and \mathbb{N} are transformation matrices.

Problem: The system matrices \mathbb{A} and \mathbb{C} must be identified on the basis of state space eq.(21) or it is required to identify $(\lambda, \varphi_\lambda)$, where λ is the set of eigen values (the poles of system matrix \mathbb{A}) and φ_λ are the set of corresponding eigen vectors of system matrix \mathbb{A} . When model order reduction techniques are applied to any system, the expected system matrices $\hat{\mathbb{A}}$ and $\hat{\mathbb{C}}$ must be identified by considering the eigen values (they effect the stability of the system) and eigen vectors.

Solution: The objective of this work is to show that the Frequency Shift Technique provides consistent estimations. The proposed technique reduces the CPU time and increases the % reduction.

VI. SIMULATION RESULTS

A. Analysis of Up-Converter

As shown in Fig. 3., an up-converter which consists of a low-pass filter, a mixer, and two bandpass filter. The components values chosen to be: $R_1=160\Omega$, $R_2=1.6k\Omega$, $R_3=500\Omega$, $C_1=C_2=C_3=10nF$, and $L_2=L_3=25.35nH$.

The transfer function of up-converter can be given as

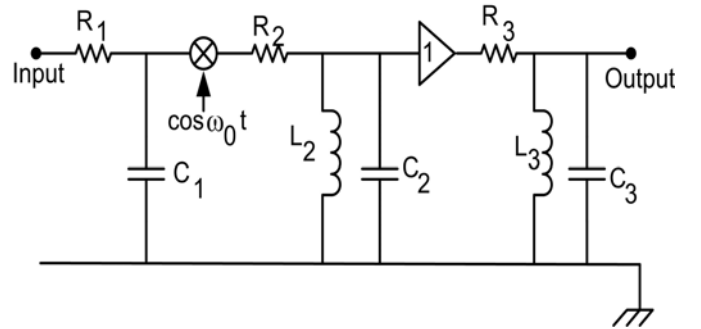

Fig. 3. Low-pass filter-mixer-two bandpass filters

$$H(s) = \frac{0.5}{1 + sC_1R_1} \frac{Z_1 Z_2}{P_1 P_2} \quad (23)$$

where,

$$\begin{aligned} Z_1 &= \frac{(s + s_0)L_2}{1 + (s + s_0)^2 L_2 C_2}; & P_1 &= R_2 + \frac{(s + s_0)L_2}{1 + (s + s_0)^2 L_2 C_2} \\ Z_2 &= \frac{(s + s_0)L_3}{1 + (s + s_0)^2 L_3 C_3}; & P_2 &= R_3 + \frac{(s + s_0)L_3}{1 + (s + s_0)^2 L_3 C_3} \end{aligned}$$

The dominant poles of transfer function of up-converter using eq. (9) is found out using frequency shift technique. Because of the numerical complexity, impulse response ($h(s, t)$) of transfer function is not shown here. The proposed method for LTV has been used to find the order reduction of the system by considering the derivatives of the network Fig. 3.

The response of the network is calculated using generic sub-space algorithm. This result is shown in Fig. 4 for both original model as well as reduced model.

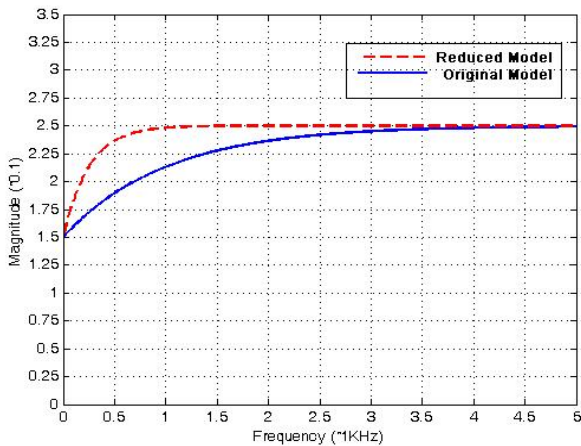

Fig. 4. Comparison of output response of original and reduced model

B. Steady State Response of LTV System using Frequency Shift Technique

Consider once again the mixer as shown in Fig. 3. Steady-state solution was first obtained using the proposed method

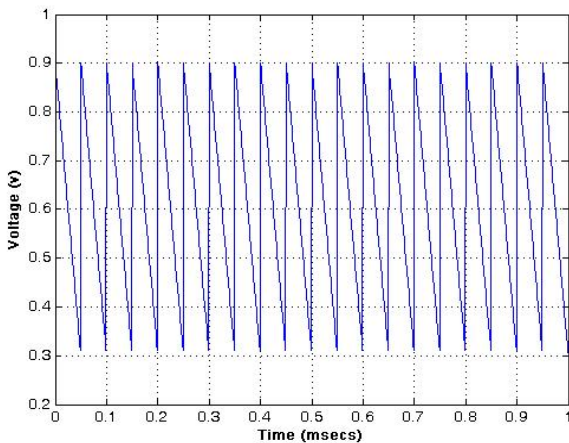

Fig. 5. Steady State Output Response

by taking the input as $e_1(t) = \sin(100 \times 10^6 t)$. Figure. 5. shows the steady state output waveform. It is observed from Fig. 5 that at peaks, the output has unwanted components. To demonstrate the efficiency of the proposed method, consider a RLC linear time variant circuit. Let us assume that the model matrix \mathbb{A} is of the order 10, 50, 250, 1000. After applying the frequency shift technique the model order has become to 6, 31, 134, and 231, respectively. All these results are tabulated in Table 1.

TABLE I
EFFICIENCY OF THE PROPOSED SCHEMES

Full Modle Size	10	50	250	1000
Frequency Shift Technique	6	31	134	231

C. Comparison with Existing Techniques

The proposed Frequency Shift Technique is compared with the existing techniques and the results are tabulated in Table 2.

TABLE II
COMPARISON WITH EXISTING TECHNIQUES-% REDUCTION AND CPU TIME

Method	Order (1918)	% Reduction	CPU Time (secs)
Elfadel [20]	690	64	55.12
Yu [21]	575	69	64.18
Pavan [9]	537	72	169.91
Roychowdhury [22]	770	61	243.12
Phillips[23]	383	79	84.81
Frequency Shift Technique	222	88	11.31

To analyze CPU time, a two port network containing a set of six coupled transmission lines as well as 12 single lines was considered. The size of the original matrices is 1918. After applying Frequency Shift Technique, the size of the reduced order model that would match the original network up to 10GHz is 222.

D. Transient Responses

In order to avoid unwanted transient response resulting from the coupling capacitors, the LTV transfer function has been expanded on the positive real axis. These transient responses have been drawn for $s_0=0$ and $s_0=10^6$ and shown in Fig. 6 and 7 respectively.

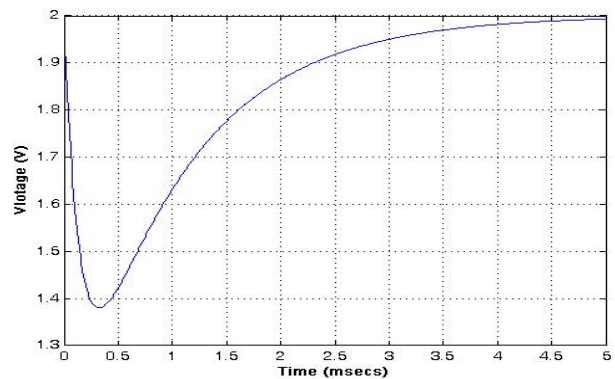

Fig. 6. Transient response for the system at $s_0 = 0$

The reliability of the Frequency Shift Technique is further demonstrated by Monte Carlo tests. Shown in Fig. 8 are the Monte Carlo test results for the RLC tree circuit with 100 runs.

From the Fig. 8, we conclude that the delays measured from the reduced-order models are mostly accurate. The rela. delay error is defined by the formula[24]. The relative-delay-error percentage mostly falls within 1%, meaning that the balancing-free square root method has an adequate robustness and results are tabulated in Table 3.

$$\frac{\text{Delay of reduced model} - \text{Delay of full model}}{\text{Delay of full model}} \quad (24)$$

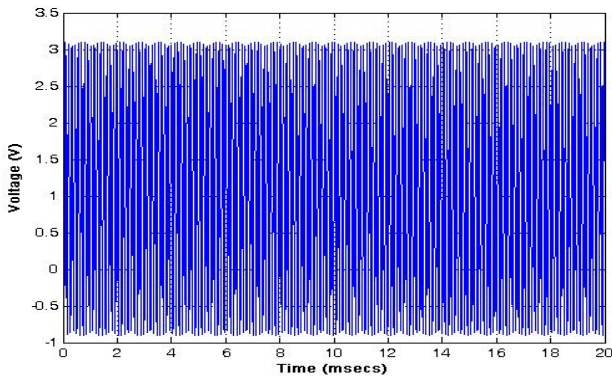

Fig. 7. Transient response for the system at $s_0 = 10^6$

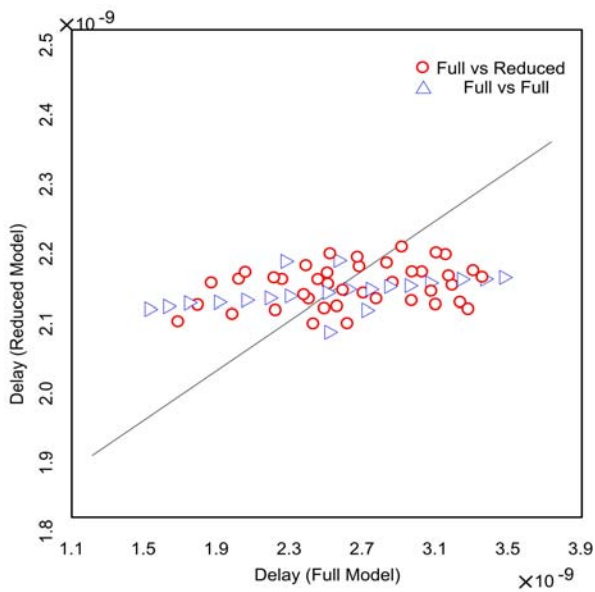

Fig. 8. Monte Carlo test of the RLC ladder circuit reduction using Frequency Shift Technique

TABLE III
SPEED UP VS MODEL SIZE

Full Model Size	10	50	250	1000
Proposed Algorithm	6	31	134	231
Speed Up	2	24	63	191
Rela. Delay Error (%)	< 0.8	< 0.6	< 0.3	< 0.15

REFERENCES

[1] S. Kumashiro, R. Rohrer, and A. Strojwas, "A new efficient method for the transient simulation of 3-D interconnect structures," *In Proceedings of International Electron Devices Meeting*, Dec. 1990, pp. 193-196.
 [2] H. W. Jhonson and M. Grahml, "High-Speed Digital Design" Englewood Cliffs, NJ: Prentice-Hall, 1993.
 [3] Dian Zhou, Wei Li, Wei Cai, Nailong Guo, "An Efficient Balanced Truncation Realization Algorithm for Interconnect Model Order Reduction" *In proceedings of International Symposium on Circuits and Systems (ISCAS)*, 2001, Vol 5, pp. 383-386.
 [4] Mike Chou, Jacob K. White, "Efficient Formulation and Model-Order Reduction for the Transient Simulation of Three-Dimensional VLSI Interconnect" *In IEEE Transactions on Computer-Aided Design of Integrated Circuits and Systems*, Vol. 16, No. 12, , December 1997, pp. 1454-1476.

[5] M. Telescu, N. Tanguy, P. Brehonnet, P. Vilbe, L.C. Calvez "Low Complexity Equivalent Circuit Models for VLSI Interconnects" *In proceedings of 10th IEEE workshop on Signal Propagation on Interconnects (SPI)*, May 2006, pp 271-273.
 [6] Eli Chiprout and Michel S . Nakhla, "Analysis of Interconnect Networks Using Complex Frequency Hopping (CFH)" *in IEEE Transactions on Computer-Aided Design of Integrated Circuits and Systems*, Vol. 14, No. 2, February 1995, pp. 186-200.
 [7] Stefano Grivet-Talocia, Andrea Ubolli "On the Generation of Large Passive Macromodels for Complex Interconnect Structures" *in IEEE Transactions On Advanced Packaging*, Vol. 29, No. 1, February 2006, pp. 39-54.
 [8] Ramachandra Achar, Michel S. Nakhla, Qi-Jun Zhang, "Full-Wave Analysis of High-Speed Interconnects Using Complex Frequency Hopping" *in IEEE Transactions on Computer-Aided Design of Integrated Circuits and Systems*, Vol. 17, No. 10, October, 1998, pp. 997-1016.
 [9] Pavan K. Gunupudi, Michel Nakhla, Ramachandra Achar "Simulation Of High-Speed Distributed Interconnects Using Krylov-Space Techniques" *in IEEE Transactions on Computer Aided Design of Integrated Circuits And Systems*, Vol. 19, No. 7, July 2000, pp. 799-808.
 [10] Pavan K. Gunupudi, Michel Nakhla, "Model-Reduction of Nonlinear Circuits using Krylov Space Techniques" *In Proceedings of IEEE/ACM Design Automation Conference (DAC)*, New Orleans, Louisiana, June 2001, pp. 13-16.
 [11] J. B. Faria, "Multiconductor Transmission Line Structures". New York: Wiley, 1993.
 [12] C. Jiao, A. C. Cangellaris, A. Yaghmour, and J. L. Prince, "Sensitivity analysis of multiconductor transmission lines and optimization for high-speed interconnect design," *in IEEE Tran on Comp, Pack, Manufactur Tech*, pp. 132-141, May 2000.
 [13] I. Wuyts and D. De Zutter, "Circuit model for plane-wave incidence on multiconductor transmission lines," *IEEE Transactions on Electromagnetics Compatibility.*, vol. 36, pp. 206-212, Aug. 1994.
 [14] R. Kay and L. Pileggi, "PRIMO: Probability Interpretation of Moments for Delay Calculation", *In Proceedings of IEEE/ACM Design Automation Conference*, San Francisco, CA, 1998, pp. 463-468.
 [15] T. Lin, E. Acar, and L. Pileggi, "h-gamma: An RC Delay Metric Based on a Gamma Distribution Approximation to the Homogeneous Response", *In Proceedings of IEEE/ACM International Conference on Computer-Aided Design*, San Jose, CA, 1998, pp. 19-25.
 [16] F. Liu, C. Kashyap, and C. J. Alpert, "A Delay Metric for RC Circuits based on the Weibull Distribution", *In Proceedings of IEEE/ACM International Conference on Computer-Aided Design*, San Jose, CA, 2002, pp. 620-624.
 [17] C. K. Cheng, J. Lillis, S. Lin, and N. Chang, *Interconnect Analysis and Synthesis*: Wiley, 2000.
 [18] L. Zadeh, "Frequency Analysis of Variable Networks", *IRE Proceedings.*, vol. 38, pp. 291-299, 1950.
 [19] Zu-Qing Qu, "Model order Reduction Techniques with Applications in Finite Element Analysis" Springer Publications 2004, ISBN: 1852338075.
 [20] I. M. Elfadel *et.al*, "A block rational Arnoldi algorithm for multiport passive model-order reduction of multiport RLC networks," *in Proceedings of . International Conference of Computer Aided Design*, Nov. 1997, pp. 66-71.
 [21] Q. Yu, *et.al* "Multipoint multiport algorithm for passive reduced-order model of interconnect networks," *in Proceedings International Symposium on Circuits and Systems*, vol. 6, Sept. 1998, pp. 74-77.
 [22] J. Roychowdhury, "Operator-based model-order reduction of linear periodically time-varying systems," *in proceedings of Design Automation Conference*, pp. 391-396, June 2003.
 [23] J. R. Phillips, "Projection-based approaches for model reduction of weakly nonlinear, time-varying systems," *IEEE Transactions on Computer Aided Design*, vol. 22, pp. 171-187, Feb. 2003.
 [24] Guoyong Shi, *et.al*, "On Symbolic Model Order Reduction", *IEEE Transactions on Computer Aided Design*, Vol. 25, No. 7, pp. 1257-1272, July 2006.