

Full Length Research Paper

Design of manual cowpea thresher

F. A. Maunde^{1*}, S. M. Yalams² and T. E. Richard³

¹Department of Agricultural and Environmental Engineering, School of Engineering and Engineering Technology, Federal University of Technology, P. M. B. 2076, Yola, Adamawa-Nigeria.

²Faculty of Education and Liberal Studies, University of Technology, Jamaica.

³Centre for Automotive Technology, Cranfield University, Silsoe Campus MK 45 4DT, UK.

Accepted 25 May, 2010

Through appropriate technology, an attempt was made to design and simulate a model of a manual cowpea thresher. Based on the outcome of threshing cowpea with conventional thresher and previous studies of properties of indigenous brown (Variety A) and RMP- 12 (Sampea -10) white (Variety B) cowpeas, design of manual cowpea thresher was carried out with an Autodesk Inventor Professional 10 software at Cranfield University. Results show that there is a requirement for primary and secondary threshing before the actual threshing with the drum to allow for the rubbing impact on the crop. Power requirement, drum speed and design through output capacity for the manual thresher (without seeds separation and cleaning) are 0.18 kW, 100 rpm, 147.7 kg/h, respectively. Issues on designs and how the threshing of cowpea will be improved were discussed in this paper.

Key words: Thresher, design, cowpea, inventor, technology.

INTRODUCTION

Cowpea (*Vigna unguiculata* L. Walp.) is an annual legume which originated from Africa and is widely grown in Africa, Latin America and Southeast Asia and in the southern United States (AMA, 1987). Cowpeas are used for human consumption and animal fodder, rich in protein and are the second economic cash crop in Africa after groundnut (Rachie and Singh, 1985). In Africa, despite the values of cowpea, the methods involved in its production, harvesting and threshing are done manually. For instance, threshing is done by pounding in a mortar with a pestle or spreading the ripped dried crop on the floor where it is beaten with a stick (Dauda, 2001). Although conventional mechanical threshers' such as the Ben-agro paddy thresher, alvan blanch aspra (ABA) Midget threshers (which are found and used in the United Kingdom). For instance as at July, 2008 the cost of ABA petrol and diesel engine in the United Kingdom was £2,877 (Two thousand eight hundred and seventy seven pounds) and £2,475 (Two thousand four hundred and seventy five pounds) respectively, this amount exclude

shipping cost, VAT clearances and custom charges. Nigerian institute of agricultural research (NIAR) multi-crop threshers are found in Zaria which is meant for research and not yet in the market (Arnon, 1987). The question is, how suitable are these conventional machines for threshing local crops such as cowpea? It has been reported (Allen and Watts, 1998), that "a conventional cylinder and concave thresher cannot be used to thresh cowpeas due to the sensitive pericarp of beans and the brittle nature". Furthermore, physiomechanical properties of cowpea have to be considered in the conventional designs (Maunde et al., 2005a). To thresh cowpea with alvan blanch master multipurpose thresher and reduce mechanical damage, there is the need for pre-threshing before the final threshing of the cowpea with the drum by rubbing action rather than impact action (Maunde, 2008; Maunde et al., 2009). The idea of manual cowpea threshing is seen as appropriate in the sense of respecting the needs, resources, environment and life styles of the people using it.

A powerful advocate was the economist E. F. Schumacher, who in his book *Small is Beautiful* (1973), wrote of (1973), wrote of "technology with a human face" and uses the term "intermediate technology". Schumacher drew on

*Corresponding author. E-mail: fatimaud@yahoo.com.

the belief of Gandhi that the poor of the world cannot be helped “by mass production,” but only by “production by the masses”. His prescription for intermediate technology required it to make use of the best of modern knowledge and experience, be conducive to decentralization, be compatible with laws of grass root evaluation of needs, be gentle in its use of scarce resources (Encarta, 2004). There after a progressive participatory design improvement from the manual can lead to the development of a motorized cowpea thresher. The participatory design procedure involves finding out what people are doing and help them do it better.

Despite the increased global importance of design process, the ultimate approach is yet to be made. This is because there is a continuous need for new, cost - effective and high quality products (Adewumi et al., 2006). In the design and production of every product, consideration should be given to the product's impact on the end users, in terms of their accessibility, affordability and comfort. This paper discusses result of a research focused on designs of a manual cowpea thresher. The study was collaboratively carried out by researchers from federal University of technology Yola in tropical Nigeria, the University of Technology, Jamaica and the Cranfield University, United Kingdom.

MATERIALS AND METHODS

Design of a manual cowpea thresher has been carried out based on outcome of threshing cowpea with a conventional thresher the alvan blanch (Maunde, 2008). (Maunde et al., 2005b, 2006, 2007). The following parameters of the thresher were determined. Principal drum parameters which include drum length, drum diameter (for primary and secondary threshing), crop feed rate, drum speed and power required to rotate the drum (Bossai et al., 1990) and (Curuthers and Rodriques, 1992). Power transmissions for manual thresher was designed based on (Rasnikov, 1991) and (Aiyeleni, 1993). System parameters which include shaft diameter, key type, bearing type, width, inner and outer diameter were determined based on calculations (Maunde et al., 2008). Structural frame included the hopper design, shape, length, bottom and top width, volume and angle of inclination were designed according to (Maunde et al., 2006) and (Maunde et al., 2007). The stress on the components parts and assembly of the thresher was determined using autodesk inventor version 10 soft ware at Cranfield University at Silsoe, UK. The software works with the principles of input data of some of the calculated parameters while some of the unknown data was automatically determined by the software.

RESULTS AND DISCUSSION

Table 1 presents the design details of threshing cylinder. For instance, the length of threshing cylinder, diameter of cylinder and feeder, cylinder concave clearance, feed (17 – 13) mm, (0.16) kg /s and (147.7) kg / h. The design results have been considered for small scale farmers who constitute 60% of the total farmers in Africa (Arnon, 1987).

Table 2 presents design details of power transmission. The sprocket without hub was selected for the handle to provide ease of manual effort to operate the thresher. The power required to turn the thresher, the chain type to fit the sprocket and handle length are (0.18 W), (roller type) and 15 cm, respectively. Appropriate/intermediate technological participatory design approach is the best for grass root evaluation of farmers needs. Hence, the need for a manual cowpea thresher before a progressive improvement of a motorized cowpea thresher. Technological gap between advance agricultural machineries is closed gradually bearing in mind the resources, affordably and ability of farmers (Li et al., 2006; Maunde et al., 2005b).

Table 3 presents detailed design of shaft. For instance a solid shaft is chosen as these agree with (Bossai et al., 1990). Diameter of the shaft, equivalent torque, factor of safety and bearing working life are (20 mm, 22.45 Nm, 3.7 and 14.2×10^7), respectively. Ergonomic and stability of any agricultural machine depend on the selection of the construction materials, bearing in mind availability, affordably not compromising quality (Curuthers and Rodriques, 1992).

Table 4 presents details of hopper and support frame. Based on (Maunde et al., 2006) and (Maunde et al., 2007), for free flow of cowpea, a combine shape is needed for its hopper (upper part rectangular and lower part trapezoidal). The shape choice was due to the brittle nature of cowpea pods and the coefficient of friction of cowpea on metal. Hopper height, hopper volume, inclination angle and total height of thresher was found (0.33 m, 0.2 m³, 40° and 1200 mm), respectively. This shows why (Allen and Watts, 1998), reported that “a conventional cylinder and concave thresher cannot be used to thresh cowpeas due to the sensitive pericarp of beans and the brittle nature” [with this result a manual cowpea thresher is hoped to emerge with high efficiency.

Figure 1 presents projected view of the manual cowpea thresher. The figure shows the hopper where the crop will be fed, a chain and sprocket which transmit the threshing force by the operator through the handle. Maunde (2008) found out that there is a need to have primary thresher before the threshing drum which will perform the secondary threshing. Hence a primary feeder is introduced in the design which preliminarily performs the threshing function before cowpea will pass through the drum and concave. A slot is designed to allow trapped cowpea to completely come out of the discharge outlet. Dauda (2001) designed and constructed manual cowpea thresher w but some of the principles like the introduction of pre thresher and discharge slot are not including. This difference might be reflected if the designed cowpea is constructed and its performance evaluated.

Conclusion and Recommendations

Design of manual cowpea thresher has been carried out

Table 1. Design details of threshing cylinder for manual thresher.

Determined parameters	Calculated values
Length of threshing cylinder (m)	0.4
Diameter of threshing cylinder (m)	0.2
Diameter of feeder (m)	0.1
Length of concave (m)	0.63
Cylinder – concave clearance (mm)	13 - 17
Width 1 of concave (m)	0.4
Width 2 of concave (m)	0.32
Volume of cylinder (m ³)	0.012
Cylinder speed (rpm)	100
Impact force of threshing cylinder (N)	14
Cylinder velocity (m /s)	3.3
Shaker length (m)	-
Shaker width (m)	-
Outlet width (m)	0.32
Outlet opening (m)	0.45
Feed rate to the cylinder (kg / s)	0.16
Thresher throughput capacity (kg/hr)	147.7

Table 2. Design details of power transmission for manual thresher.

Determined parameters	Selected and calculated values
Sprocket type	Sprocket without hub
Teeth on the larger sprocket	40
Teeth on the smaller sprocket	20
Force to rotate sprocket (N)	130
Power required (W)	0.18
Chain type	Roller type
Chain length (cm)	102
Velocity of handle (m / s)	3.7
Handle diameter (cm)	4.8
Handle length (cm)	15

Table 3. Design details of shaft for manual cowpea threshers.

Determined parameters	Selected and calculated values
Shaft type	Solid type
Torque on shaft (Nm)	20.53
Diameter of shaft (mm)	20.0
Equivalent torque on shaft (Nm)	22.45
Factor of safety	3.7
Shaft key type	Square key type
Key width (mm)	6
Key height (mm)	6
Bearing type	Radial contact ball bearing
Bearing design life (rpm)	1.8×10^7
Bearing design load (N)	218.04
Basic dynamic rating (N)	570.88
Bearing working life (hr)	14.2×10^7

Table 4. Design details of hopper and support frame for manual cowpea thresher.

Determined parameters	Selected and calculated values
Hopper shape	*Combine
Hopper height (m)	0.33
Hopper top width (m)	0.7
Hopper bottom width (m)	0.54
Hopper volume (m ³)	0.2
Inclination angle (0°)	40
Length of frame (mm)	750
Breadth length (mm)	250
Total frame height (mm)	1200.

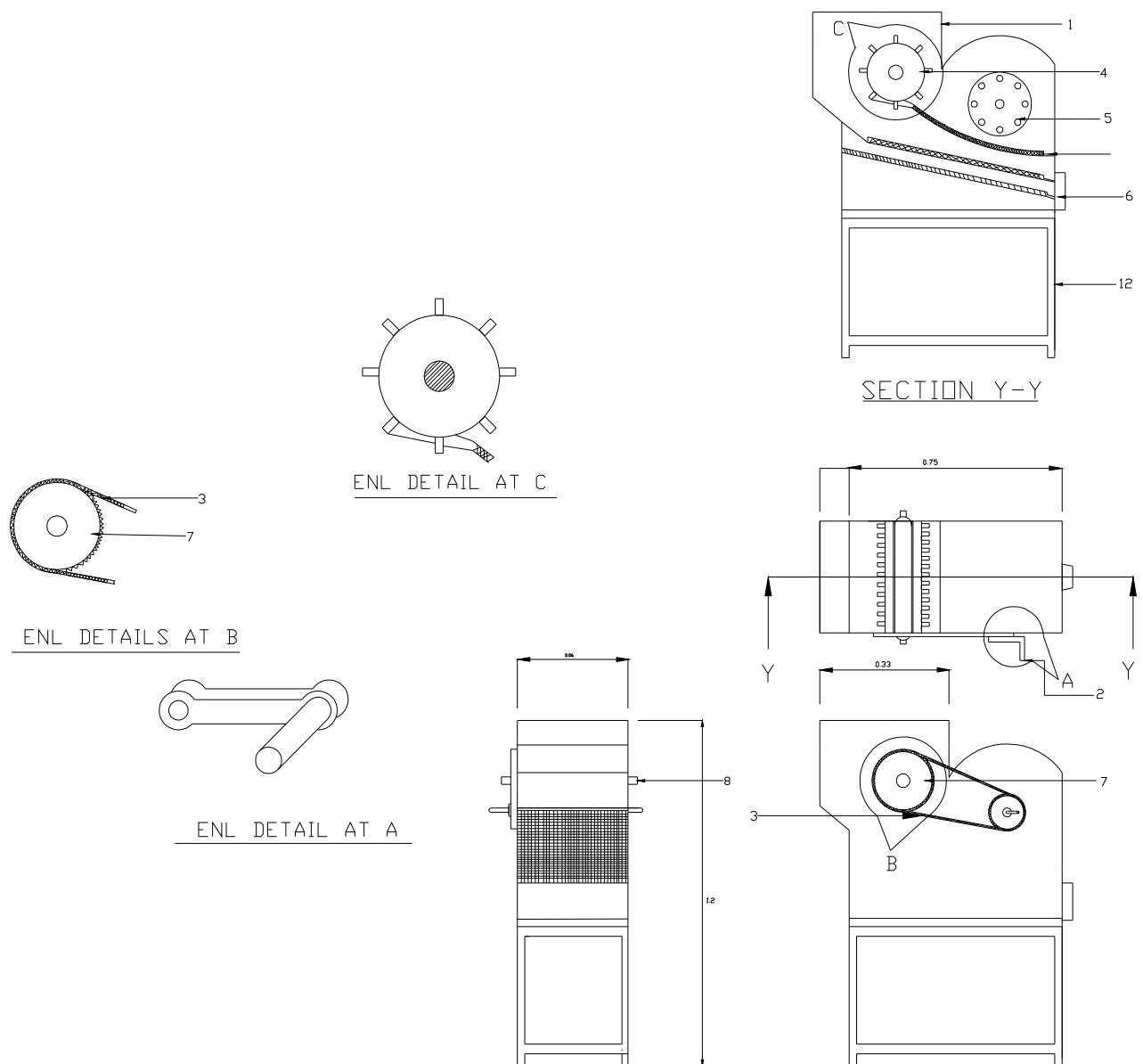

Figure 1. Manual cowpea thresher projected view.

1. Hopper, 2. Handle, 3. Chain 4. Feeder (pre – thresher) 5. Drum and concave, 6. Discharge slot 7. sprocket, 8. shaft, 12. support frame.

based on previous researches. Embodiment designs and detailed designs were carried out. The manual thresher is designed to be operated by hand using a chain and sprocket drive system and has a design throughput capacity of 148 kg/h. There is no provision for separation of seeds from the chaffs on the manual thresher. Total length, width and frame height is 750 mm, 250 mm and 1200 mm, respectively. It is recommended that this cowpea thresher be constructed based on the design specifications. When the thresher is successfully constructed and performance evaluated, it is hoped that the labor intensive and time consuming efforts during manual threshing of cowpea will be relegated to the past not only in Nigeria, but in the whole of Africa and beyond. This should result in an increase in the provision of needed proteins for the populace and increases the farmers' holdings. It is recommended that the manual cowpea thresher be modified into motorized cowpea thresher. This will show progressive transfer of technology of manual cowpea threshing with sticks and pounding in mortar and pestle to a manual threshing with machine and into combine motorized cowpea threshing which include the separation of seed from chaff by the thresher blower. This will reduce drudgery of cowpea threshing and increase cowpea production.

ACKNOWLEDGEMENTS

The authors of this paper acknowledge association of Commonwealth Scholarship, who sponsored this research. Also the kind contribution of Noel Hathorn for assisting with the Autodesk Inventor applications is much appreciated.

REFERENCES

- Adewumi B, Ademosun O, Ogunlowo A (2006). Preliminary Investigation on the Distribution and Spread Pattern of Cowpea in a Cross Flow Grain Separator. *Agricultural Engineering International: CIGRE j. Manuscript FP 06 020. VIII*. <http://cigr-journal.tamu.edu/submissions/volume8/FP%2006%20020%20Adewumi%20final%208Nov2006.pdf>.
- Aiyeleni UA (1993). An evaluation of some parameters relating to cowpea threshing. *Niger. J. Sci.* 27:41-49.
- Allen CAW, Watts KC (1998). Design of a Belt Thresher for Cowpea Beans, *AMA. Inter. Agri. Mechan. Asia, Africa and Latin America.* 29 (3): 42-54. <http://sciencelinks.jp/j-east/article/199911/000019991199A0225140.php>.
- AMA (1987). *International Journal of Agricultural Mechanization in Africa, Asia and Latin America* 15(3): 109-111.
- Arnon I (1987). *Modernization of Agriculture in Developing Countries: Resources, Potentials and Problems.* 2nd Edition, John Wiley and Sons, Chichester, pp. 38-45.
- Bossoi ES, Verniaev OV, Smirnov II, Sultan Sheikh EG (1990). *Theory Construction and Calculation of Agricultural Machines.* New Delhi, Calcutta. 2: 374-389.
- Curruthers I, Rodrigues M (1992). *Tools for Agriculture: A guide to appropriate Equipment for Small Scale Farmers.* Fourth Edition, Intermediate Technology (ITP) Publishers Ltd. Southampton Row, London, pp. 115-118.
- Dauda A (2001). Design, Construction, and Performance Evaluation of a Manually Operated Cowpea Thresher for Small Scale Farmers Northern Nigeria 32(4): 47-49. <http://sciencelinks.jp/j-east/article/200207/000020020702A0114705.php>
- Encerta M, Premium S (2004). *Modern Agriculture and Machineries* compiled by inc./ will and Deni; and McIntyre and Benelux.
- Li KD, Vincent G, Zheng L (2006). Universal Accessibility Assessments through Virtual Interactive Design. *Int. J. Hum. Factors Modelling Simul.* 1: 52-68.
- Maunde FA, Ali MA, El-Okene A (2005a). *Appropriate Postharvest Technology in Adamawa State, Egwe, E.C., Mshellia, S. I. and Jada, M.Y.* (Eds), First Edition Paraclete Publishers, Yola, Nigeria pp. 311-324.
- Maunde FA, Maduako JN, Ali MA, Elaija N (2005b). Investigation of Physicomechanical Properties of Two Cowpea Varieties. *J. Agric. Technol.* 13: 31-42.
- Maunde FA, Ali MA, El-Okene A, Riji BB (2006). Physicomechanical Properties of Some Cowpea Varieties for the Mechanization of Threshing Operation. In: *International Conference of Engineering Research and Development: Impact on Industry (5th – 7th September, 2006), University of Benin, Nigeria* pp. 382-386.
- Maunde FA, Ali MA, El-Okene A, Riji BB (2007). Determination of Physicomechanical Properties of Cowpea to Aid Thresher Designs. *Advanced Material Research, Trans Tech Publication Switzerland.* 18(19): 159-164. Available at: <http://technology.materials-science.net/0-87849-450-2/159/>.
- Maunde FA (2008). *Study of Cowpea Threshing with Alvan Blanch Aspra Master*, part of Visiting PhD Research Report for Six Months submitted to the department of Agricultural Engineering, Cranfield University at Silsoe (un published).
- Maunde FA, Brighton JL, Mohammed HM (2009). Study of cowpea threshing with Alvan Blanch Aspra Master. *Inter. J. Eng. Res. Global J. Eng. Tech. India* 2(2): 285-291.
- Rachie KO, Singh SR (1985). *Research Production and Utilization of Cowpea.* Second Edition, Willey Interscience Publication Great Britain. pp. 53-75.
- Rasnikov A (1991). *Fundamental of Designing and Calculating Farm Machinery.* Agroprom publishers, Moscow, 8th edition 52(76): 216-220, 321(323): 616-618.
- Schumacher EF (1973). *Small is Beautiful : A study of Economics as if people mattered.* Available at : www.gettech.org/ Accessed on 1st July, 2004.