

Mating Sequence and Evidence for the Existence of a Female Contact Sex Pheromone in *Brontispa longissima* (Coleoptera: Chrysomelidae)

Kei KAWAZU^{1,3}, Ryoko T. ICHIKI^{1,2}, Dung T. DANG¹, and Satoshi NAKAMURA^{1*}

¹ Japan International Research Center for Agricultural Sciences (JIRCAS) (Tsukuba, Ibaraki 305-8686, Japan)

² Biosystematics Laboratory, Graduate School of Social and Cultural Studies, Kyushu University (Nishi, Fukuoka 812-8581, Japan)

Abstract

To clarify the presence of a pheromone in *Brontispa longissima* (Coleoptera: Chrysomelidae), we observed its mating behavior and conducted a series of bioassays. When male and female *B. longissima* came in contact, the male was observed to hold and mount the female, extend its penis toward her abdominal tip, and copulate. The male was observed to hold the female only after he had touched her with his antennae and/or forelegs. Males showed similar mating attempts toward females killed by freezing. On the other hand, no males showed mating attempts toward females washed with hexane, but they did toward females washed with hexane and re-treated with hexane extract of the female body or female elytra. Furthermore, males showed similar mating attempts toward a glass dummy treated with a solvent extract of female elytra. These results indicate the presence of a female sex pheromone that is perceptible by direct contact and plays an important role in mating in *B. longissima*. When the crude extract of female elytra was subjected to silica gel chromatography, only the fraction eluted with hexane elicited mating behavior in males. Furthermore, when the active fraction was chromatographed on AgNO₃-impregnated silica gel, only the fraction eluted with hexane elicited mating behavior in males. The contact sex pheromone of *B. longissima* is therefore believed to consist of one or more less-polar compounds, probably saturated hydrocarbons.

Discipline: Insect pest

Additional key words: coconut, hydrocarbon, mating behavior

Introduction

The coconut hispine beetle, *Brontispa longissima* (Gestro) (Coleoptera: Chrysomelidae), is one of the most serious pests of the coconut palm, *Cocos nucifera* L. (Arecaceae), and of several ornamental palms^{11,15}. This beetle is thought to be native to Indonesia and Papua New Guinea, but it was accidentally introduced into Vietnam in 1999, and has been spreading rapidly to other countries, such as Thailand, the Philippines, and Hainan Province in China^{11,12,15}. *B. longissima* inhabits the young and unopened fronds of the crown of coconut palms in all its developmental stages¹. Both larvae and adults damage the leaflets of the fronds by eating the surface tissues, resulting in the russet browning of

the leaves, a decrease in fruit production, and eventually withering and death^{11,15,23}. The eggs of *B. longissima* hatch after an incubation period of about five days. The larval period is 30 to 40 days, followed by a prepupal period of three days and a pupal period of six days. The adult lives up to 220 days. The preoviposition period is one to two months²⁰. In spite of being one of the most serious pests of the coconut palm, the ecological and physiological aspects of this insect have been little studied, and their mating behavior and how it is regulated have hitherto not been investigated.

In Southeast Asia, the coconut palm has many uses and produces economically and industrially important crops such as copra, coconut oil, and coconut shell charcoal¹¹. In addition, coconut trees are commonly planted in coastal

Present address:

³ National Institute for Agro-Environmental Sciences (Tsukuba, Ibaraki 305-8604, Japan)

*Corresponding author: e-mail s.nakamura@affrc.go.jp

Received 27 January 2010; accepted 15 April 2010.

areas, nurseries, parks, and gardens to act as land cover, parterres, and as topiary. Severe attacks by *B. longissima* lead to russet brown leaves and therefore completely disfigure palms that are grown for ornamental purposes²³. To protect coconut palms from infestation damage by *B. longissima*, there is an urgent need to investigate methods of controlling the populations of this beetle in Southeast Asia. However, chemical control using insecticides cannot be applied due to the beetle inhabiting the crowns of tall trees, and insecticides also pose risks to the environment. We have therefore been aiming to control the beetle using its pheromones. It is thought that applications of contact pheromone can raise the efficiency of the infection of filamentous fungus¹⁰.

In Coleoptera, the function of the cuticular hydrocarbons as contact sex pheromones have been extensively investigated in several taxa, such as Cerambycidae^{2,6}, Coccinellidae⁷, Curculionidae¹⁴, and Staphylinidae¹⁷. However, among the Chrysomelidae, the presence of contact sex pheromones has been reported in only a few species: the Colorado potato beetle, *Leptinotarsa decemlineata*^{9,13,16}, the Japanese green duck leaf beetle, *Gastrophysa atrocyanea*¹⁹, the blue milkweed beetle, *Chrysochus cobaltinus*¹⁸, the dogbane leaf beetle, *Chrysochus auratus*¹⁸, and the mustard leaf beetle, *Phaedon cochleariae*⁵. Although contact sex pheromones play an important role in mating behavior, they have been chemically identified in only one species, *G. atrocyanea*¹⁹. Fundamental research is necessary to develop applications using synthetic pheromones; however, biological research concerning mating behavior and sex pheromones is a relatively unexplored area.

Analysis of the mating behavior of *B. longissima* will provide valuable insight into the diversity of mating systems of this beetle and assist in the development of techniques for pest control. We therefore conducted observation of the mating sequence to clarify the characteristics of the female sex pheromone in *B. longissima*.

Materials and methods

1. Insects

The *B. longissima* used in this research were obtained from colonies maintained by the National Biological Control Research Center, Kasetsart University, and the Department of Agriculture (DOA), Thailand. Since it is difficult to obtain fresh leaves of coconut plants in Japan, we instead reared the beetle colony on fresh leaves of the narrow leaf cattail, *Typha angustifolia* L. (Typhaceae), an alternative host plant of this beetle^{21,22}. Larvae and adults were maintained separately on fresh leaves in plastic containers (15.5 cm long x 11.5 cm side x 5.0 cm high) with a mesh window in the lid. All procedures were conducted at 25°C under a 12L:12D photoperiod and 65% relative humidity.

2. Observation of mating behavior

All observations of mating behavior were carried out using an experimental arena (Fig. 1). A male and female were placed on a filter paper sheet (76 x 26 mm) surrounded by glass (thickness 2 mm, placed on the top). The mating behavior of 35 pairs of beetles was continuously observed for 30 min. The mated females and males were used. Although *B. longissima* showed multiple mating, the effect of multiple mating on the mating behavior of adults was not found in our preliminary experiments. Observation of the mating behavior of adults, 3–8 weeks after emergence, was conducted 7–11 h after lights on under 12L:12D, 25°C. In preliminary experiments, the same level of frequency in mating behavior was observed between 3–8 weeks.

3. Extraction

The females were killed by freezing for 1 hr at -20°C. The elytra of the killed females were dissected and extracted

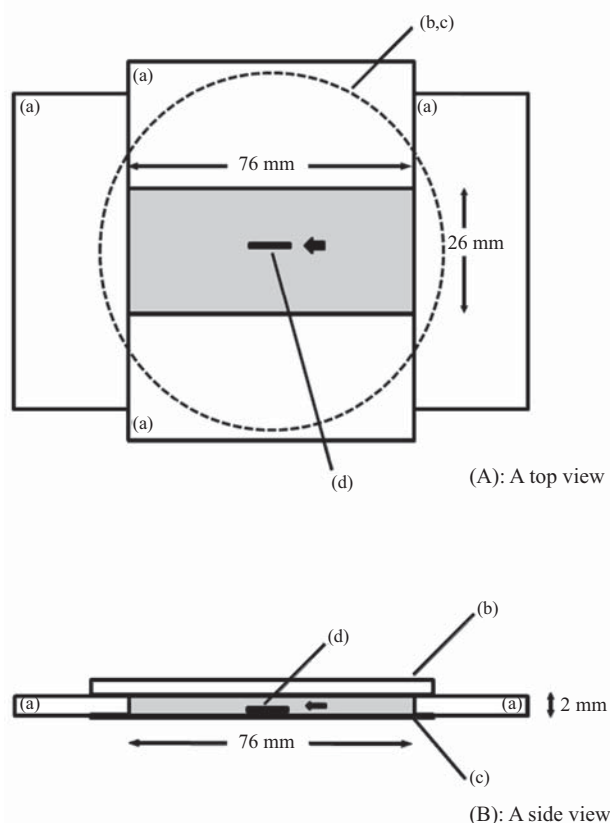

Fig. 1. A schematic figure of all observations and bioassays

The gray area shows the experimental arena (76 x 26 mm) surrounded by glass (thickness 2 mm, placed on the top). A black glass dummy coated with a test solution is examined by a male *B. longissima*. A: top view, B: side view. (a) Slide glass (76 x 26 mm; thickness 2 mm), (b) glass plate (90 mm diameter), (c) filter paper (90 mm diameter), (d) black glass dummy coated with test solution. The arrow shows the release point of the male.

with hexane (ca. 1 mL / female) for 1 h. After the elytra had been removed and filtrated, the crude extracts were stored at -20°C until use.

4. Chromatography

The crude extract of female elytra (50 FE: female equivalent) was poured onto a silica gel column (30mm x 5mm ID, 200 mg, Wakogel C-200, 200 mesh, Wako Pure Chemical Industries Ltd.), and successively eluted with 2 mL each of hexane, then 5%, 15%, and 50% ether in hexane and ether. The active fraction was further fractionated by column chromatography on 200 mg of silica gel impregnated with 10% AgNO₃ (30mm x 5mm ID, 200 mesh, Aldrich Chemical Company, Inc.). The column was then eluted successively with 2 mL each of hexane and 0.5%, 1%, 2%, and 5% ether in hexane. All the solvent was distilled before use.

5. Bioassay for sex pheromone

Laboratory bioassays were conducted with the experimental arena (Fig. 1). Males 3–8 weeks after emergence were bioassayed at 7–11 h after lights on under 12L:12D, 25°C. Pheromonal activity was evaluated using a black glass dummy (9.0 x 1.6 mm; 1.0 mm thickness). Color effect on male mate orientation was demonstrated in *Xylotrechus pyrrhoderus*⁸, *Anoplophora malasiaca*⁴, and *holotrichia loochooana loochooana*³. Since mating behavior in *B. longissima* was also thought to be elicited by a visual stimulus, a black dummy that resembles natural female colors was used. However, in our present experiments, the effect of the black dummy on the mating behavior in *B. longissima* could not be confirmed. The dummy was coated with a test solution using a glass syringe and placed at the center of the experimental arena. A male was placed nearby and allowed to make contact with it. Behavior was continuously observed for 30 min. The sexual maturity of the 3–8 weeks-old males used in the bioassay was confirmed through observation of abdominal bending behavior toward intact females. Thirty replications were performed for each bioassay.

6. Statistical analysis

Each statistical analysis was performed using JMP (version 5.0.1 J for windows, SAS Institute Inc., Cary, NC, USA 2004). Male response was analyzed using a nominal logistic regression analysis with William's adjustment. Pairwise comparisons of male response were determined by a likelihood ratio chi-square test using contingency table analysis with the Holm adjustment.

Results and discussion

1. Mating sequence in *Brontispa longissima*

To clarify the existence of a pheromone in this species, the mating behavior of 35 pairs of *B. longissima* was observed (Fig. 2). Both females and males showed wandering behavior before the encounter, waving their antennae. Of the 35 pairs examined, 91% encountered each other within 30 minutes and showed contact behavior, in which males approached females and touched them with their antennae and/or forelegs. We present two possible explanation for the male's approach to female within short range: 1) stimulatory volatiles and/or 2) visual stimulus. This remains to be proved in the future. After the male touched the female with his antennae and/or forelegs, he grabbed her with his forelegs (holding, 91%). The male then licked her back with his palpi, aligned his body axis with that of the female, and mounted her (mounting, 86%). Most males (63%) licked the female's backs again during mounting behavior. The male then bent his abdomen to contact the tip of the

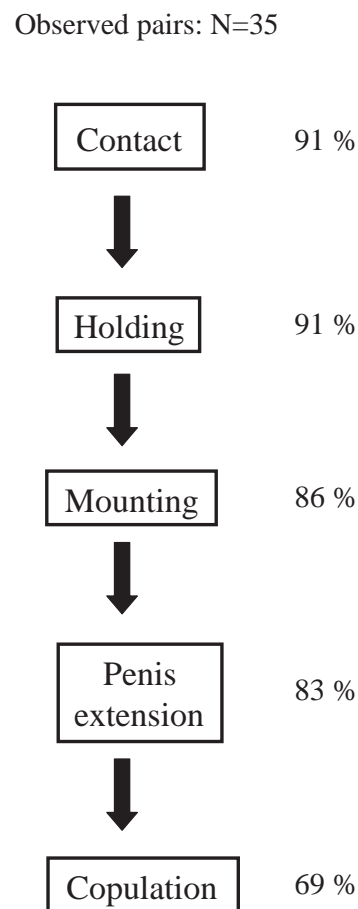

Fig. 2. Mating sequence in *B. longissima* (N = 35)

Each value indicates the percent of males exhibiting the behavior in 35 observations.

female abdomen (penis extension, 83%), and copulated successfully (copulation, 69%). Thus, we classified male behavior into five phases: contact, holding, mounting, penis extension, and copulation. Since the five phases of male behavior are conducted step by step, this mating sequence is considered to be behavior formulated with extremely high probability. Similar mating sequences were observed after encounters between males and females in several other Chrysomelidae: *L. decemlineata*^{9,13,16}, *G. atrocyanea*¹⁹, and *P. cochleariae*⁵. When the male *B. longissima* attempted to mate, some females walked away. This behavior was observed when the male attempted holding and mounting behavior. This was concluded to be mate refusal behavior by female *B. longissima*.

The mating sequence of *B. longissima* appeared to start from direct contact by a male with his antenna or tarsus of the foreleg to the female antenna, pronotum, or elytra. Only when a male contacted a female with his antennae and/or tarsi were further male responses, such as holding, mounting, penis extension, and copulation, observed. Male contact with the antennae, tarsi, or palpi was considered to be

involved in perception of female-specific cues. The importance of direct contact in mating behavior has been demonstrated in other Chrysomelidae: *L. decemlineata*^{9,13,16}, *G. atrocyanea*¹⁹, *C. cobaltinus*¹⁸, and *C. auratus*¹⁸. However, more detailed examinations will be needed to determine the presence of attractant cues in the mating behavior of *B. longissima*. There still remains a possibility that other cues work in the near vicinity of individuals or for long-distance attraction in association with host plant odor.

2. Behavioral response of male *B. longissima* toward live or dead females

In the bioassays, males showed mating attempts comprising penis extension toward females that had been killed by freezing at -20°C (Fig. 3). No males showed penis extension behavior toward females that had been washed with hexane. When the washed females were re-treated with the hexane extract from a female body or female elytra, males again showed penis extension toward those females. These results indicate the presence of a female sex pheromone that is perceptible by direct contact and plays an important role

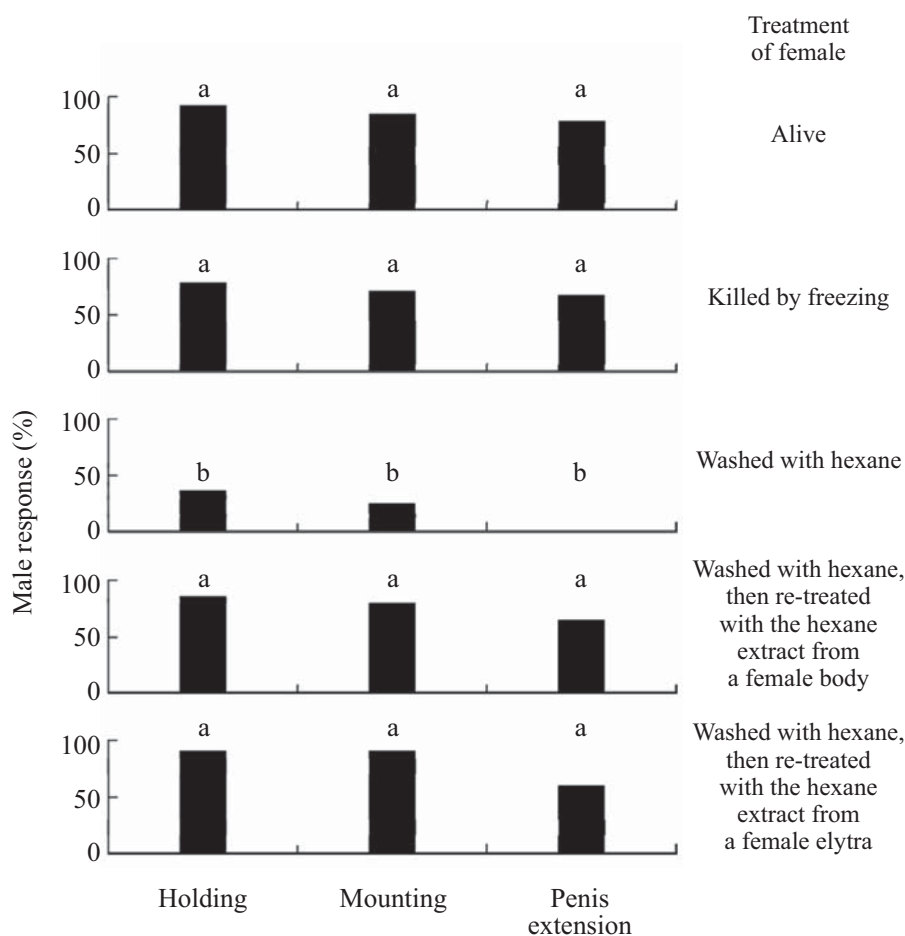

Fig. 3. Behavioral response of male *B. longissima* to live or dead females (N = 30)

Values in the same response followed by the same letter were not significantly different according to nominal logistic regression analysis.

in the mating of *B. longissima*.

3. Behavioral responses of males toward a dummy coated with female extract

When a male touched a black glass dummy coated with 1 FE of female elytra extracts, males showed holding, mounting, and penis extension behavior toward the dummy (Fig. 4). This behavior was similar to behavior toward intact females. The male response was enhanced when the dose of the extract was increased. This dose-dependent relationship indicates that mating behavior is stimulated in males by a chemical factor, i.e., a female sex pheromone. However, the percentage of male responses to the dummy

with the extract tended to be smaller than to intact females (Figs. 3 and 4). There is a possibility that non-chemical, visual, acoustic, or tactile cues might play a role in sexual communication of *B. longissima* in addition to the chemical cue.

4. Behavioral responses of males toward a glass dummy coated with chromatographic fractions

Male responses toward a glass dummy coated with fractions obtained from silica gel column chromatography are shown in Figure 5. Only the non-polar hexane fraction elicited as much holding and mounting as did the crude extract. The non-polar hexane fraction and crude extract

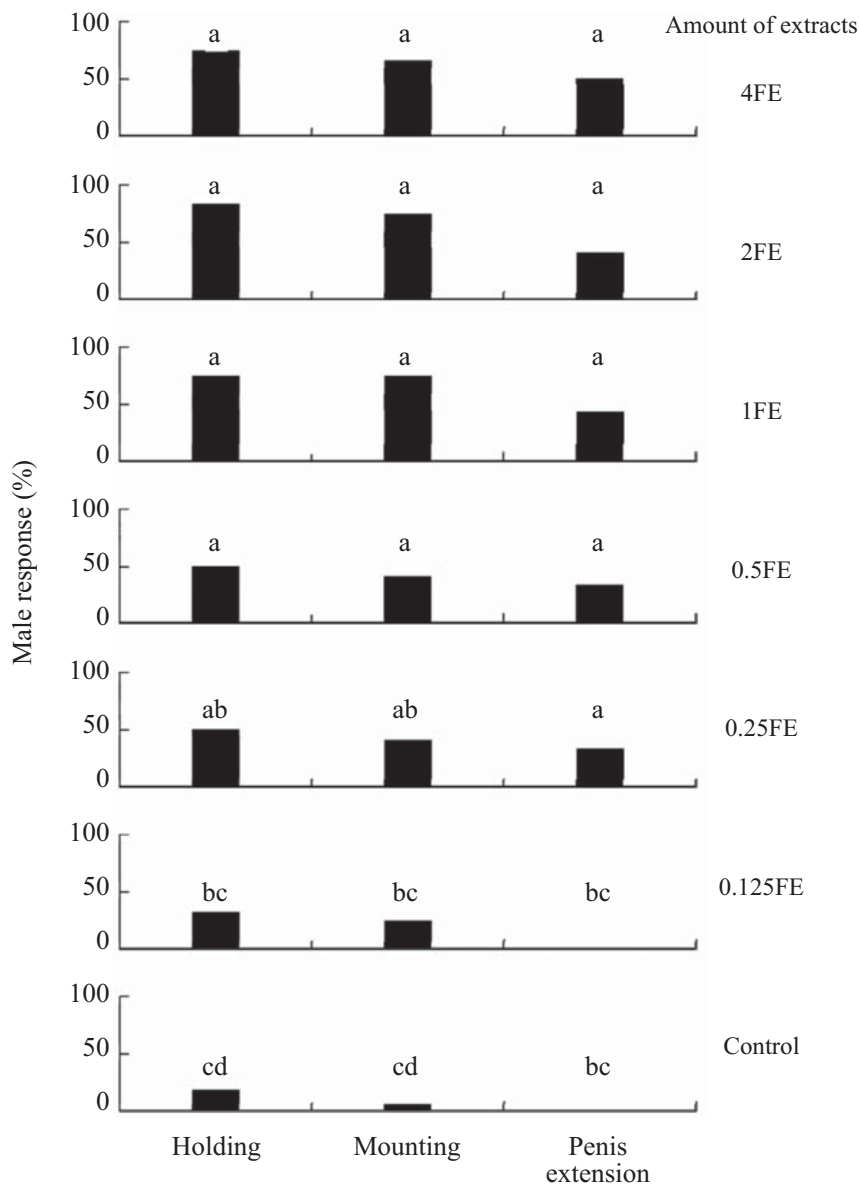

Fig. 4. Behavioral responses of males toward a dummy coated with female extract (N = 30)

Values in the same response followed by the same letter were not significantly different according to nominal logistic regression analysis.

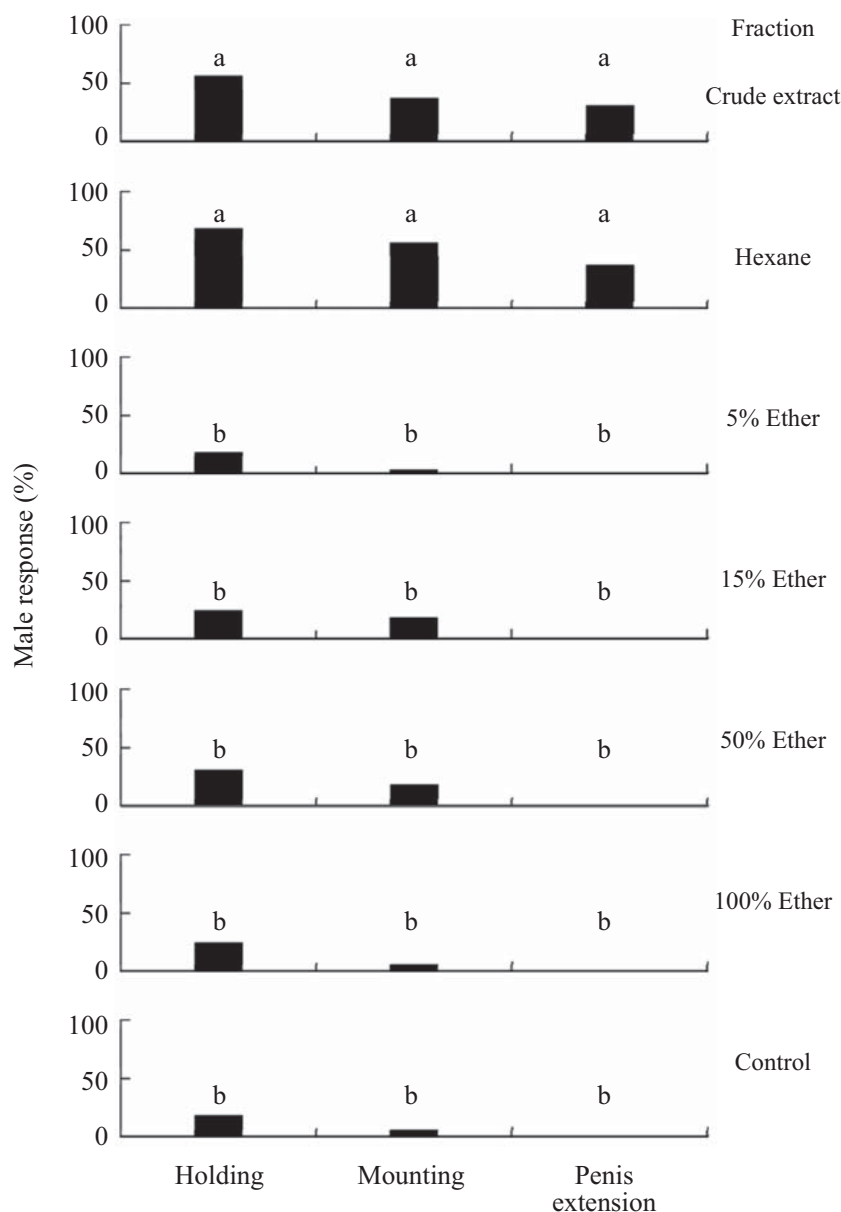

Fig. 5. Behavioral responses of males toward a glass dummy coated with silica gel column chromatographic fractions (N = 30)
Values in the same response followed by the same letter were not significantly different according to nominal logistic regression analysis.

significantly elicited penis extension. The polar fractions, however, did not (Fig. 5), indicating that one or more non-polar compounds, probably hydrocarbons, function as contact sex pheromones in *B. longissima*.

5. Behavioral responses of males toward a glass dummy coated with AgNO₃-impregnated silica gel column chromatographic fractions

The active hexane fraction was further fractionated by column chromatography on AgNO₃-impregnated silica gel. The fraction eluted with hexane and crude extract significantly elicited male holding and mounting (Fig. 6). The

fraction eluted with hexane elicited as much penis extension as did the crude extract, whereas ether fractions, which are considered to contain alkenes, elicited none (Fig. 6). The contact sex pheromone of *B. longissima* is therefore considered to consist of one or more non-polar compounds, probably saturated hydrocarbon(s). In *G. atrocyanea*, the mono-methyl alkanes 9-methyl heptacosane, 11-methyl heptacosane, 9-methyl nonacosane and 11-methyl nonacosane, 13-methyl heptacosane, 13-methyl nonacosane, 15-methyl nonacosane, and *n*-alkanes were identified as components of the contact sex pheromone¹⁹. It will be necessary to elucidate the chemical structure and function of the contact pher-

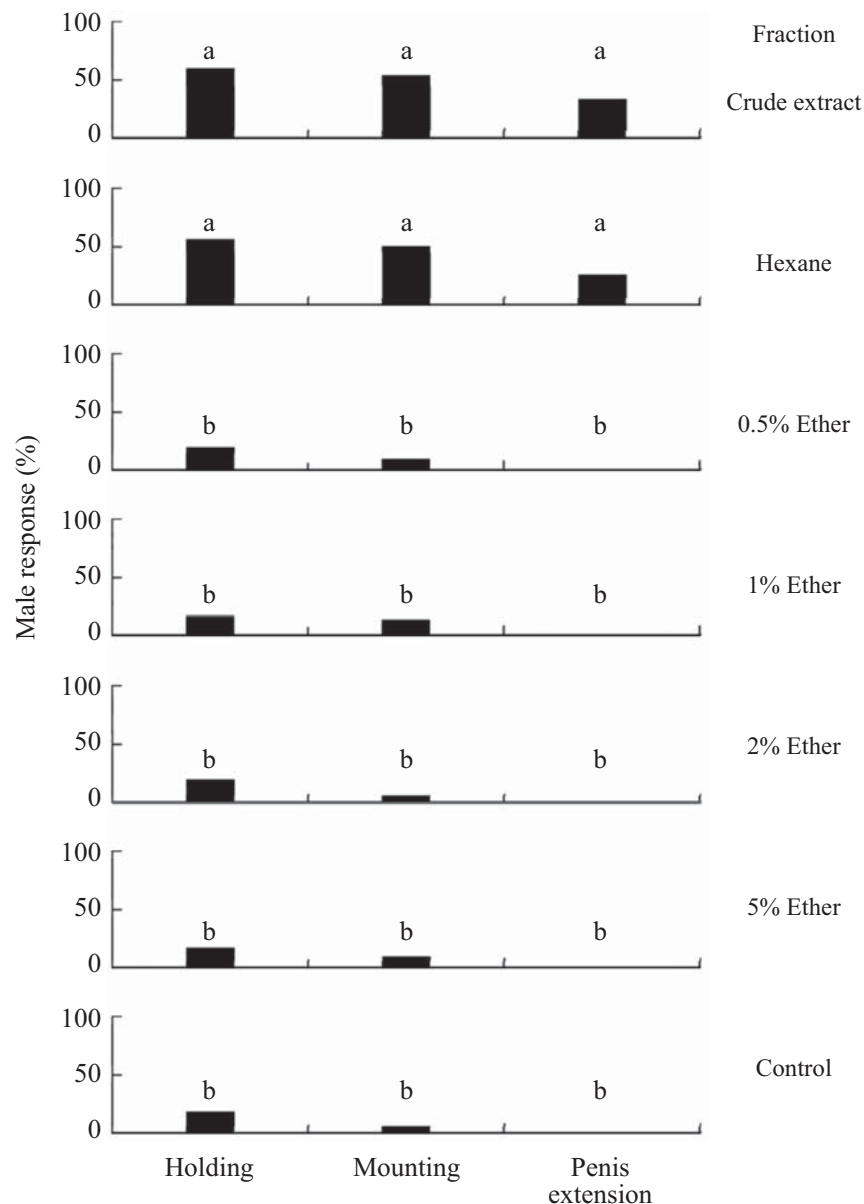

Fig. 6. Behavioral responses of males toward a glass dummy coated with AgNO_3 -impregnated silica gel column chromatographic fractions (N = 30)

Values in the same response followed by the same letter were not significantly different according to nominal logistic regression analysis.

omone distributed on the female body surface to understand mating behavior in *B. longissima*.

Acknowledgments

We would like to thank Wiwat Suasa-ard, Sopon Uraichuen, Kittiya Suksen, Rut Morakote, Amporn Winotai, and Thitraporn Pundee for providing experimental devices and insects. We would also like to thank Chieko Yokokura for her technical assistance. We are grateful to Professor Sadahiro Tatsuki of the University of Tokyo and Professor

Yoichi Kainoh of the University of Tsukuba for valuable suggestions on the experiment.

References

1. Brown, E. S. & Green, A. H. (1958) The control by insecticides of *Brontispa longissima* (Gestro) (Coleopt., Chrysomelidae-Hispinae) on young coconut palms in the British Solomon Islands. *Bull. Entomol. Res.*, **49**, 239–272.
2. Fukaya, M. et al. (1996) Reproductive biology of the yellow-spotted longicorn beetle, *Psacothaea hilaris* (Pascoe) (Coleoptera: Cerambycidae).
3. Identification of contact sex

- pheromone on female body surface. *J. Chem. Ecol.*, **22**, 259–270.
3. Fukaya, M. et al. (2004) Effects of color on male orientation to female pheromone in the black chafer *Holotrichia lochooana lochooana*. *Chemoecology*, **14**, 225–228.
 4. Fukaya, M. et al. (2005) Effect of size and color of female models for male mate orientation in the white spotted longicorn beetle, *Anoplophora malasiaca* (Coleoptera: Cerambycidae). *Appl. Entomol. Zool.*, **40**, 513–519.
 5. Geiselhardt, S., Otte, T. & Hilker, M. (2009) The role of cuticular hydrocarbons in male mating behavior of the mustard leaf beetle, *Phaedon cochleariae* (F.). *J. Chem. Ecol.*, **35**, 1162–1171.
 6. Ginzl, M. D. et al. (2003) Role of contact pheromones in mate recognition in *Xylotrechus colonus*. *J. Chem. Ecol.*, **29**, 533–545.
 7. Hemptinne, J. L. et al. (1998) Mate recognition in the two-spot ladybird beetle, *Adalia bipunctata*: role of chemical and behavioural cues. *J. Insect Physiol.*, **44**, 1163–1171.
 8. Iwabuchi, K. (1985) Mating behavior of *Xylotrechus pyrroderus* Bates (Coleoptera: Cerambycidae) II. Female recognition by male and the existence of a female sex pheromone. *Appl. Zool. Entomol.*, **20**, 416–423.
 9. Jermy, T. & Butt, B. A. (1991) Method for screening female sex pheromone extracts of the Colorado potato beetle. *Entomol. Exp. Appl.*, **59**, 75–78.
 10. Kimura, S. (1996) *Konchu ni manabu (Learning from insect)* Kogyo Chosakai, Tokyo, pp. 284 [In Japanese].
 11. Liebrechts, W. & Chapman, K. (2004) Impact and control of the coconut hispine beetle, *Brontispa longissima* Gestro (Coleoptera: Chrysomelidae). In Report of the expert consultation on coconut beetle outbreak in APPPC member countries. Ed. by FAO Regional Office for Asia and the Pacific, FAO, Bangkok, Thailand, 19–34.
 12. Lu, B. et al. (2008) Biological assessment in quarantine of *Asecodes hispinarum* Bouček (Hymenoptera: Eulophidae) as an imported biological control agent of *Brontispa longissima* (Gestro) (Coleoptera: Hispididae) in Hainan, China. *Biol. Control*, **45**, 29–35.
 13. Mpho, M. & Seabrook, W. D. (2003) Functions of antennae and palpi in the mating behavior of the Colorado potato beetle *Leptinotarsa decemlineata* (Coleoptera: Chrysomelidae). *Bull. Entomol. Res.*, **93**, 91–95.
 14. Mutis, A. et al. (2009) Evidence of contact pheromone use in mating behavior of the raspberry weevil (Coleoptera: Curculionidae). *Environ. Entomol.*, **38**, 192–197.
 15. Nakamura, S., Konishi, K. & Takasu, K. (2006) Invasion of the coconut hispine beetle, *Brontispa longissima*: Current situation and control measures in Southeast Asia. In Proceedings of international workshop on development of database (APASD) for biological invasion. vol 3. Ed. by Ku TY, Chiang MY, Taiwan Agricultural Chemicals and Toxic Substance Research Institute, Taichung, Taiwan, Food and Fertilizer Technology Center (FFTC) for the Asia and Pacific Region, Taipei, Taiwan, 1–9.
 16. Otto, V. D. (1997) Some properties of the female sex pheromone of the Colorado potato beetle *Leptinotarsa decemlineata* Say. (Col. Chrysomelidae). *Anz. Schadlingskde Pflanzenschutz Umweltschutz*, **70**, 30–33.
 17. Peschke, K. & Metzler, M. (1987) Cuticular hydrocarbons and female sex pheromones of the rove beetle, *Aleochara curtula* (Goeze) (Coleoptera: Staphylinidae). *Insect Biochem.*, **17**, 167–178.
 18. Peterson, M. A. et al. (2007) Profiles of cuticular hydrocarbons mediate male mate choice and sexual isolation between hybridising *Chrysochus* (Coleoptera: Chrysomelidae). *Chemoecology*, **17**, 87–96.
 19. Sugeno, W., Hori, M. & Matsuda, K. (2006) Identification of the contact sex pheromone of *Gastrophysa atrocyanea* (Coleoptera: Chrysomelidae). *Appl. Entomol. Zool.*, **41**, 269–276.
 20. Waterhouse, D. F. & Norris, K. R. (1987) *Brontispa longissima* (Gestro). Biological control: ACLAR, Inkata Press, Melbourne, pp. 131–141.
 21. Winotai, A., Sindhusake, C. & Morakote, R. (2007) Brief review on biological control of coconut hispine beetle *Brontispa longissima* in Thailand. In: *The APCC/FAORAP/APPCC consultative meeting on the IPM of Brontispa longissima*. ed Arancon RN Jr, FAO, Bangkok, Thailand, 228–273.
 22. Yamashita, A., Winotai, A. & Takasu, K. (2008) Use of mature leaves of coconut palm and narrowleaf cattail for laboratory rearing of the coconut leaf beetle *Brontispa longissima*. *Bull. Inst. Trop. Agr. Kyushu Univ.*, **31**, 61–67.
 23. Yamauchi, S. (1985) Some notes of the *Brontispa longissima* Gestro (Coleoptera: Chrysomelidae). *J. Okinawa Agri.*, **20**, 49–53 [In Japanese].