

The evaluation of dynamic cracking resistance of chosen casting alloys in the aspect of the impact bending test

J.Sadowski^{a,*}, T.Szykowny^b

^a Department of Thermal Engineering and Metrology, Mechanical Engineering Faculty, University of Technology and Life Sciences, av. Kaliskiego 7, 85-796 Bydgoszcz, Poland

^b Department of Materials Science and Engineering, Mechanical Engineering Faculty, University of Technology and Life Sciences, av. Kaliskiego 7, 85-796 Bydgoszcz, Poland

* Corresponding author. E-mail address: kms@utp.edu.pl

Received 18.04.2008; accepted in revised form 29.04.2008

Abstract

The increase of quality and durability of produced casting alloys can be evaluated on the base of material tests performed on a high level. One of such modern test methods are tests of the dynamic damage process of materials and the evaluation on the base of obtained courses $F(f)$, $F(t)$ of parameters of dynamic cracking resistance K_{Id} , J_{Id} , performed with the usage of instrumented Charpy pendulums. In the paper there was presented the evaluation of dynamic cracking resistance parameters of casting alloys such as: AK12 aluminum alloy, L20G cast steel and spheroid cast iron. The methodology of the evaluation of that parameters was described and their change as well, for the AK12 alloy with the cold work different level, L20G cast steel cooled from different temperatures in the range $+20^{\circ}\text{C}$ – -60°C , and for the spheroid cast iron in different stages of treatment i.e. raw state, after normalization, spheroid annealing and graphitizing annealing. Obtained parameters of dynamic cracking resistance K_{Id} , J_{Id} of tested casting alloys enabled to define the critical value of the a_d defect that can be tolerated by tested castings in different work conditions with impact loadings.

Keywords: Mechanical properties; Dynamic crack resistance; Casting alloys

1. Introduction

Commonly applied test methods for evaluation of dynamic cracking resistance of materials are basically quality tests used for evaluation of KCV impact strength and material plasticity i.e. to compare whether the material is brittle or plastic [1].

Nowadays, there is an attempt to make these tests more versatile, especially considering the Charpy V impact strength test. It is being done by equipping Charpy pendulums in electronic systems: the ones that record, process and analyze fast variable courses taken in the impact bending test i.e. force – time

$F(t)$, force – displacement $F(f)$, displacement – time $f(t)$, with the usage of computer aided processing of courses e.g. by the FRACDYNA software [2,3]. Such systems are commonly known as CAI (Computer Aided Instrumented Charpy Impact Testing).

Expanded impact strength tests performed in such a way enable:

- evaluation of basic parameters of dynamic cracking resistance i.e. critical value of the dynamic stress intensity coefficient K_{Id} or critical value of dynamic Rice's J_{Id} integral on the base of criteria resulting from dynamic

fracture mechanics on Charpy V type specimens with a fatigue notch [4,5,6,7],

- precise measurement of impact strength and an expanded analysis of an influence of i.e. metallurgical factors, heating treatment method, temperature influence etc. on material hardness on initiation and propagation of cracking [8,9],
- analysis of influence of notching technology and material plastic properties on the value of energy needed to initiate the material fracture [8,9],
- precise evaluation of the tested material damage process by separation of global damage work K to components of this work i.e.: K_z - work for fracture initiation, K_r - work for cracking propagation, K_h - work of cracking braking in individual stages of the specimen damage [10,11].

The first of the mentioned points is the topic on the following paper with reference to chosen casting alloys.

Current tests in the range of application of the fracture mechanics are performed in three areas [12,13]:

- description of the stress fields in the neighborhood of the defect node,
- evaluation of crack resistance of materials,
- evaluation of selection and load capacity of designed structures e.g. castings with crack.

The least attention is paid to the third topic, but still it is very important one. Conditions of cracking initiation of casting materials with the usage of criteria of fracture mechanics can be described by formulas (1)-(5) [6,13,14]:

$$K_I = K_{IC} \quad (1)$$

$$J_I = J_{IC} \quad (2)$$

$$K_I(t) = K_{Id} \quad (3)$$

$$J_I(t) = J_{Id} \quad (4)$$

$$\frac{da}{dN} = C \left(K \right)^m \quad (5)$$

Presented formulas (1) and (2) are appropriate for static loadings, formulas (3) and (4) for dynamic loadings (impact ones) and the formula (5) for fatigue loadings. Application of these criteria, as conditions of the sudden damage of the structure, consists in theoretical calculation of the stress intensity coefficient, K_I static or $K_I(t)$ dynamic one, which is identified with the critical value of the cracking resistance: static K_{IC} (formula 1) or dynamic K_{Id} (formula 3) one experimentally obtained [12,14].

Relationships (1) and (3) characterize cracking of brittle materials as an element of linear fracture mechanics. In the similar way as an element of linear fracture mechanics characterizing cracking of plastic materials, there is defined the criterion of the sudden static damage (formula 2) and the dynamic one (formula 4) by appropriate determination of Rice's J integral (both theoretical and experimental one). Defined by relationships (1)-(5) criteria of the sudden damage by spontaneous growth of the crack (node) can be accepted as a measure of usability of a

material applied for castings and cracking resistance characteristics presented on the right side of that formulas are quantities characterizing the individual casting material and they can be considered as constants of the material accepted for castings.

Applying criteria of fracture mechanics described by formulas (1)-(5) the casting material can be chosen for their particular application by [13,14]:

- determination of current casting strength with the presence of increasing cracks (defects),
- determination of the allowable crack size (critical defect) with assumed level of working loadings,
- determination of the period of crack (defect) increase time from the moment of its detection to the moment in which it reaches the critical value,
- determination of the period of time among necessary following non-destructive tests in order to detect forming and developing cracks (defects).

2. Methods of determination of dynamic cracking resistance

From known methods of evaluation of dynamic cracking resistance parameters, there can be mentioned methods concerning evaluation of these parameters for brittle materials (linear dynamic fracture mechanics) [15] and for elastic-plastic materials (non-linear dynamic fracture mechanics) [14,15,18,19].

According to ASTM [15] and BS6729 [16] standards, plasticity conditions are determined on the base of ratio of the recorded F_m force to diffraction of the bent specimen f_f . If F_m/f_f and $0,5 F_m/f_{0,5}$ do not differ between each other more than 10% then the material is considered as brittle. That is why for brittle materials a force parameter is applied and the critical value of the critical value of the dynamic stress intensity coefficient K_{Id} is calculated by the formula [6,8,14,15]:

$$K_{Id} = \frac{F_p \cdot L}{B \cdot W^{3/2}} \left[2,9 \left(\frac{a}{w} \right)^{1/2} - 4,6 \left(\frac{a}{w} \right)^{3/2} + 21,8 \left(\frac{a}{w} \right)^{5/2} - 37,6 \left(\frac{a}{w} \right)^{7/2} + 38,7 \left(\frac{a}{w} \right)^{9/2} \right] \quad (6)$$

where: F_p -value of the force initiating cracking determined on course $F(f)$, a –length of the crack in the specimen, L –distance between supports of the pendulum, B – width of the specimen, W –height of the specimen.

For the calculation of the critical value of the integral J_{Id} the formula (7) has been used:

$$J_{Id} = \frac{2E_p}{B(w-a)}, \quad (7)$$

where: E_p - strain energy of the impact bent specimen corresponding to the area under the load – deflection characteristic in the initiation point, in Jouls, B - thickness of the specimen, in mm, w - width of the specimen, in mm, a - length of the gap in specimen, in mm.

The essential problem of the correct determination of dynamic cracking resistance parameters during impact bending such as K_{Id} , J_{Id} , T_{mat} etc. on the base of knowledge of recorded courses $F(t)$, $F(f)$ is finding the cracking initiation point and on this base determination of F_p force and E_p energy – needed for cracking initiation in different materials.

A relatively precise and applicable compliance change method $\Delta C/C$ of the impact bent specimen [14,17] was applied as an evolution method of the crack initiation point which allows for calculations of the J_{Id} parameter. The compliance changing rate is defined as:

$$\Delta C/C = \left(\frac{1}{C} - \frac{1}{C_e} \right) C_e, \quad (8)$$

where: $\Delta C/C$ –compliance changing rate, C -secant compliance, mm/N, C_e - elastic compliance, mm/N.

As $\Delta C/C$ against the deflection is plotted, a sudden transition point of the gradient appears on the plot of $\Delta C/C$, as it is schematically shown in Figure 1.

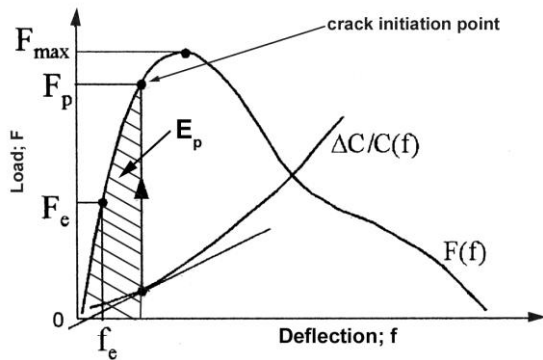

Fig. 1. Schematic explanation of the compliance changing rate method

From formulas (3) and (4) having determined parameters of dynamic cracking resistance K_{Id} , J_{Id} , one can calculate the defect critical value accepted by the material in conditions of dynamic loadings according to the formula [3,8]:

$$a_d = \frac{E \cdot J_{Id}}{(1 - \nu^2) \pi R_d} \cdot Y \quad (9)$$

where: R_d – dynamic plasticity limit, Y - defect shape coefficient, J_{Id} - the critical value of the Rice's integral J_{Id} , E -Young modulus, ν - Poisson coefficient.

3. Own tests

Test results

For evaluation of dynamic cracking resistance parameters K_{Id} , J_{Id} with the usage of the instrumented impact bending test, impact tests of several casting alloys were performed with the instrumented pendulum PSd 300 with the usage of $F(f)$ course processing software FRACDYNA [10,14] especially its VII and VIII mode. That mode was used to calculate parameters of dynamic cracking resistance K_{Id} , J_{Id} with formulas (6) and (7), and also for the critical defect size a_d (formula 8). Tests were performed on chosen casting alloys i.e. AK12 aluminum alloy, L20G cast steel and spheroid cast iron, using results of the previously presented paper on evaluation of the decohesion process of the impact damage of that castings [10].

Tested casting alloy AK12 had a chemical composition 11,5% Si, 0,8% Cu and 0,9%Mg. Specimens for impact tests in order to determine KCV and dynamic cracking resistance K_{Id} , J_{Id} were performed with accordance to figure 2. That specimens had to be deepen with an additional fatigue gap with accordance to requirements of the ASTM standard.

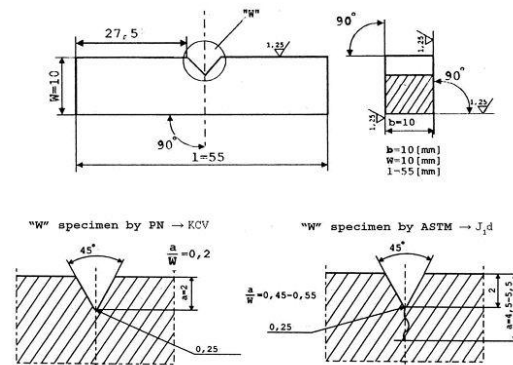

Fig. 2. Dimensions of specimens for KCV impact tests and dynamic cracking resistance K_{Id} , J_{Id}

Additionally there was introduced to specimens a cold work in the range from 0 to 10%. Exemplary $F(t)$ courses for determination of K_{Id} , J_{Id} parameters with different stages of the cold work according to the method of the flexibility change of the impact bent specimens were presented in fig. 3.

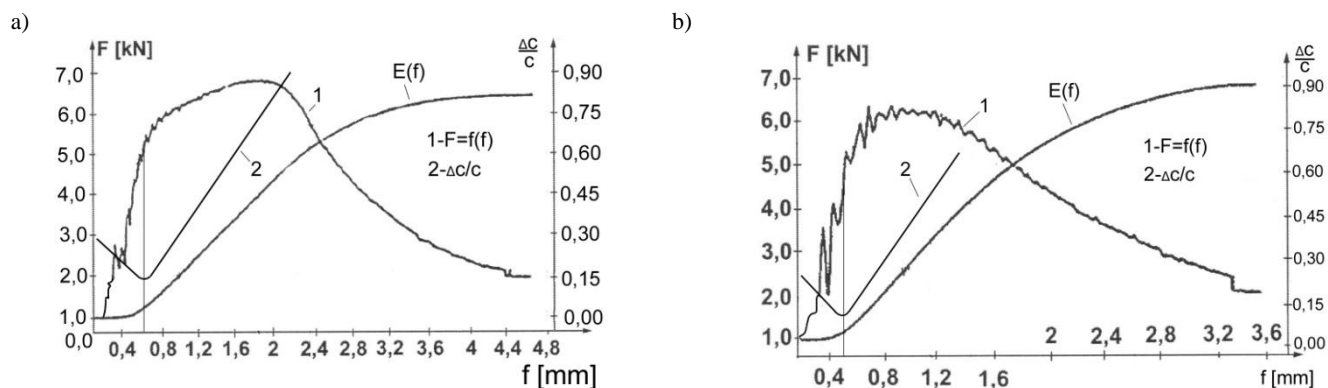

Fig. 3. Exemplary $F(f)$ courses for AK12 tested alloy, determination of force and energy of the crack initiation with the method of flexibility change a) for the cold work b) for the 5% cold work

Tabular and graphical comparison of results of dynamic cracking resistance evaluation for the AK12 tested casting with dependence on the level of the cold work was presented in the table 1 and in figure 4.

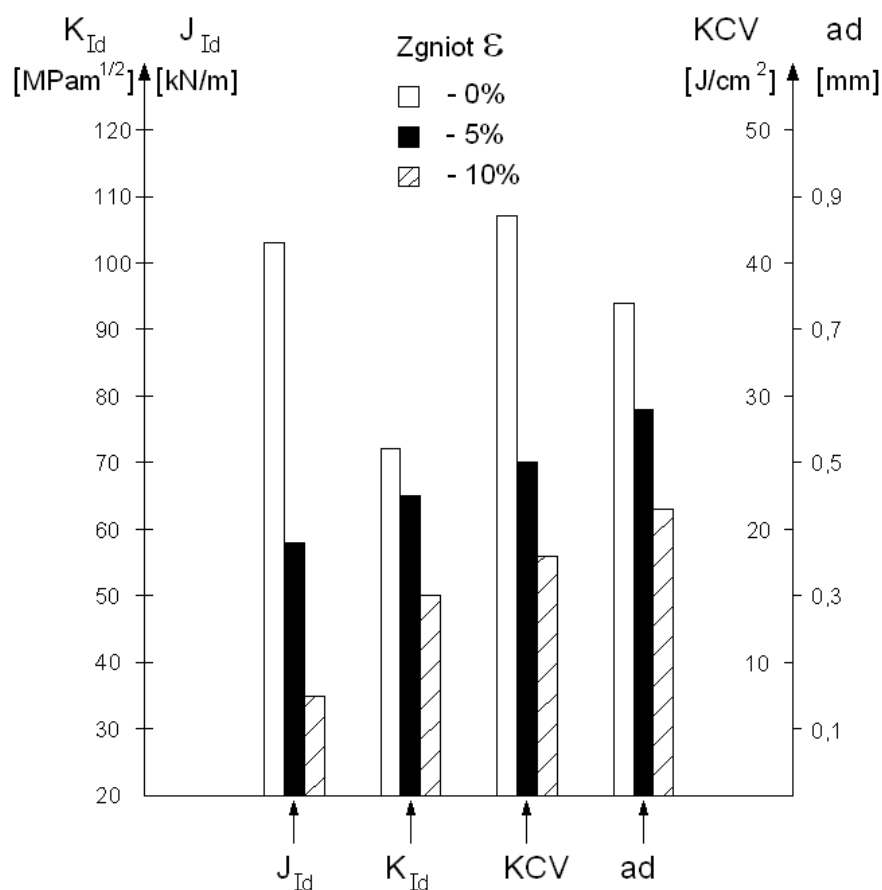

Fig 4. Graphical comparison of dynamic cracking resistance results for the AK12 alloy

Table 1.
Results of AK12 dynamic cracking resistance tests during impact bending

| Cold work % | Force [kN] | Energy [J] | Dynamic cracking resistance | | Allowable defect length | Impact strength KCV [J/cm ²] |
|-------------|----------------|----------------|--|------------------------|-------------------------|--|
| | F _p | E _p | K _{Id} [MPam ^{1/2}] | J _{Id} [kN/m] | a _d [mm] | |
| 0 | 5,09 | 3,24 | 72 | 102 | 0,72 | 43 |
| 5 | 4,55 | 1,50 | 66 | 57 | 0,58 | 25 |
| 10 | 2,75 | 1,33 | 51 | 34 | 0,48 | 18 |

Tested low-carbon cast steel L20G had the chemical composition: 0,25% C, 0,47% Si, 1,38% Mn, 0,0025% P and 0,020% S. In advance the cast steel was normalized in the temperature 850°C in time 4 h, and then annealed in the temperature 600°C in time 2 h. Impact specimens were broken from different temperatures of cooling from 20°C to -60°C defining impact strength KCV and dynamic cracking resistance parameters K_{Id}, J_{Id} with the method of the flexibility change on specimens deepened with the fatigue gap (fig. 2).

In tab. 2 and in fig. 5 there is presented the comparison of obtained test results.

Table 2.
Test results of the L20G cast steel dynamic cracking resistance during impact bending

| Testing temp. °C | Force [kN] | Energy [J] | Dynamic cracking resistance | | Allowable defect length | Impact strength KCV [J/cm ²] |
|------------------|----------------|----------------|--|------------------------|-------------------------|--|
| | F _p | E _p | K _{Id} [MPam ^{1/2}] | J _{Id} [kN/m] | a _d [mm] | |
| 20 | 6,94 | 5,39 | 103,5 | 178 | 0,89 | 74,1 |
| 0 | 5,73 | 4,13 | 98,1 | 125 | 0,62 | 55,5 |
| -20 | 4,25 | 3,98 | 89,6 | 102 | 0,43 | 40,2 |
| -40 | 4,01 | 3,67 | 82,4 | 51 | 0,28 | 28,4 |
| -60 | 3,96 | 2,39 | 78,2 | 35 | 0,17 | 17,3 |

Tested spheroid cast iron had the chemical composition: 3,28% C, 2,39% Si, 0,43% Mn, 0,08% P and 0,014% S.

Impact specimens after different heat treatments were broken without any notch to evaluate the impact strength KCV, and in the case of determination of dynamic cracking resistance parameters K_{Id}, J_{Id} because of problems with an introduction of the fatigue notch (large fragility, lack of K_n cracking braking work), there appeared notching with a thin abrasive disk on depth approx. 1 mm.

In tab. 3 and in fig. 6 there were presented results of dynamic cracking resistance of tested spheroid cast iron after different phases of the heat treatment.

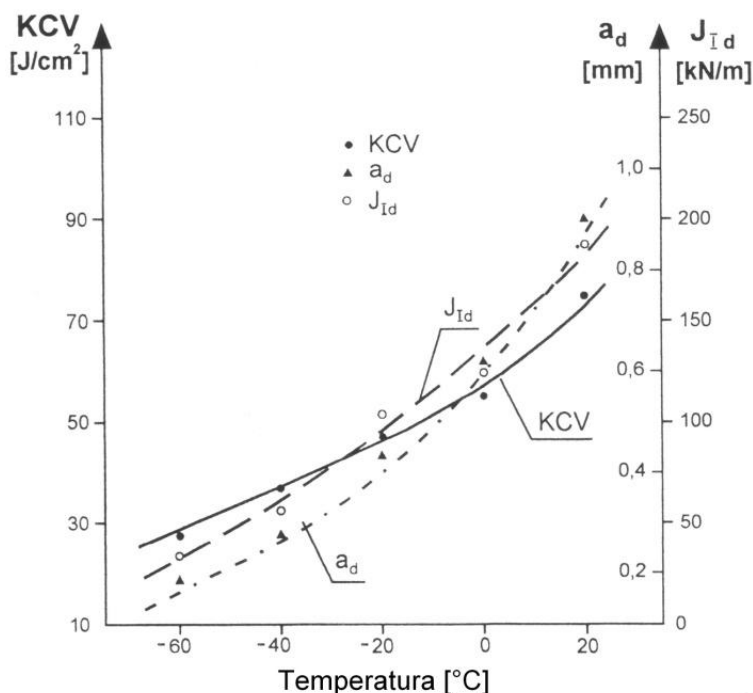

Fig. 5. Changes of dynamic cracking resistance J_{Id}, impact strength KCV and a_d allowable defect size with the reference to the temperature of L20G tested cast iron

Table 3.
Results of spheroid cast iron dynamic cracking resistance tests during impact bending

| Phase of heat treatment | Force [kN] | Energy [J] | Dynamic cracking resistance | | Allowable defect length a_d [mm] | Impact strength KCV [J/cm ²] |
|-------------------------|------------|------------|---------------------------------|-----------------|------------------------------------|--|
| | F_p | E_p | K_{Id} [MPam ^{1/2}] | J_{Id} [kJ/m] | | |
| Raw state (s) | 4,40 | 0,61 | 37,9 | 19,2 | 0,31 | 15,9 ^a |
| Normalization (N) | 30,3 | 0,41 | 31,5 | 16,1 | 0,22 | 8,9 ^a |
| Graphitization (G) | 3,75 | 0,39 | 44,1 | 21,3 | 0,44 | 37,6 |
| Spherodization (S) | 4,05 | 0,47 | 52,5 | 23,7 | 0,53 | 21,8 |

Spheroid cast iron normalizing was performed in the temperature 900°C in time 6 h. Cast iron graphitizing consisted in heating to the temperature 975°C, soaking for 1 h, next slow cooling in a furnace to the temperature 720°C, soaking in that temperature in time 5 h and further cooling in the air.

Cast iron spheroid annealing was performed in two operations i.e. heating to the temperature 950°C, soaking for 2 h and cooling in the air, next heating to the temperature 700°C, soaking in that temperature for time 4 h and next cooling in the air.

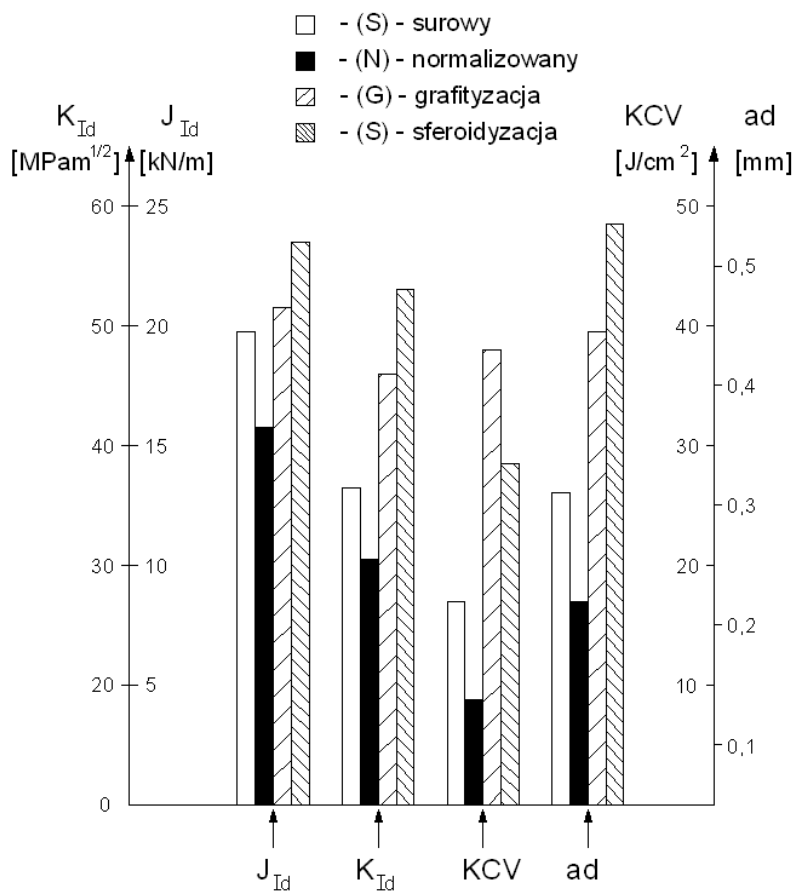

Fig. 6. Graphical comparison of dynamic cracking resistance for tested spheroid cast iron

Presented in tables 1, 2 and 3 results of dynamic cracking resistance tests of tested casting alloys are averages of three impact broken specimens.

4. The analysis of test results

From the obtained test results of dynamic cracking resistance determination for K_{Id} , J_{Id} tested casting alloys results, that they essentially depend on the alloy type, its chemical composition, initial state (method of the heat treatment), cooling temperature, cold work level, etc. Analyzing the influence of the cold work level of the AK12 alloy on dynamic cracking resistance (tab.1, fig.3 and 4) there can be stated that the higher cold work level the lower K_{Id} , J_{Id} dynamic cracking resistance parameters. The same corresponds to the change of the impact strength KCV and the critical length of allowable defect a_d in the tested alloy. This leads to conclusion that introduction of the higher cold work level causes the change of cracking character from plastic ($\varepsilon=0\%$) to plastic-brittle one ($\varepsilon=10\%$), what appears with the sudden decrease of cracking resistance parameters K_{Id} , J_{Id} and the character of curves $F(f)$ (fig.3). There is possible in further tests to determine the empirical relationship among dynamic cracking resistance parameters and the cold work level and the impact strength i.e. K_I , $J_{Id}=f(KCV, \varepsilon)$.

Analyzing the obtained tests results of dynamic cracking resistance J_{Id} , a_d for the L20G cast steel, cooled from different temperatures (tab.2, fig. 5), there can be determined on the base of obtained curves, correlation among cracking resistance and temperature T and impact strength KCV, can be described by formulas:

$$J_{Id} = KCV \cdot (e^{-0,374+0,445 \cdot 10^{-2} T}) \quad (9)$$

by $R=0,9958$
and

$$a_d = KCV \cdot (e^{-8,084+1,186 \cdot 10^{-2} T}) \quad (10)$$

by $R=0,9924$

Presented formulas (9) and (10) enable to estimate dynamic cracking resistance parameters on the base of simple impact tests in different temperatures. However, confirmation of these formulas requires further experiments, for larger number of tests than assumed in the paper and the similar chemical composition of cast steel.

From the analysis of obtained test results showed in tab. 3 and fig.6, for tested spheroid cast iron, destroyed without any notch or with the insignificant one, results that the heat treatment method essentially influences on improvement or decrease of cast iron dynamic cracking resistance parameters. From cast iron heat treatment methods proposed in the paper results, that the most advisable variant of the heat treatment from the point of view of cracking resistance is spheroid annealing that increases dynamic cracking resistance almost twice in relation to e.g. normalizing state. Also allowable size of tolerated defect a_d is for this operation the highest, even though the impact strength KCV in insignificantly lower in relation to graphitization of this cast iron. Further tests on the spheroid cast iron should be pointed on setting of optimum strength properties in relation with optimum cracking resistance and impact strength KCV, by different heat treatments, therefore searching of the correlation K_{Id} , $J_{Id}=f(Rm, KCV)$.

5. Conclusions

1. Instrumented impact bending test performed with the usage of impact pendulums, on the base of knowledge of the obtained course $F(f)$, enables not only the precise definition of the KCV impact strength but also K_{Id} , J_{Id} dynamic cracking resistance parameters and the a_d critical defect size in the tested material in conditions of dynamic loadings.
2. It was stated, that the AK12 aluminum alloy tested in the work, processed with the cold work, shows almost three times decrease of dynamic cracking resistance K_{Id} , J_{Id} by its increase from 0 to 10%.
3. Tests of L20G dynamic cracking resistance changes showed that there is the correlation among dynamic cracking resistance and cooling temperature T and impact strength KCV, that was presented in the paper by proper relationships (8) and (9).
4. Tests of spheroid cast iron K_{Id} , J_{Id} dynamic cracking resistance parameters showed, that those values essentially change with relation to the heat treatment method. Spheroid annealing improves dynamic cracking resistance almost two time in relation to the normalized state of this cast iron.
5. Further tests of casting materials should be pointed on optimizing of high mechanical properties of these materials in correlation with good dynamic cracking resistance.

References

- [1] S. Butnicki, Weldability and steel brittleness, Wydawnictwo Naukowo-Techniczne. Warszawa, 1993.
- [2] E. Ranatowski, J. Sadowski, Physical interpretation of impact bend test by means of mathematical methods. Applied Mathematics and Computer Science, No 2, 1993, 157-165.
- [3] J. Sadowski, T. Szykowny, Relation between the dynamic fracture toughness and impact resistance KCV as well as structure of selected frictionally welded joints, The Archive of Mechanical Engineering, Vol LI, 2004, No 3, 453-465.
- [4] T. Kabayashi T., Introduction of new dynamic fracture toughness evaluation system. Journal of Testing and evaluation, 1993, Vol.21, No 3, 145-153.
- [5] T. Kabayashi, Development in the instrumented impact test – computer aided instrumented impact testing system. Charpy Centenary Conference 2001, 127-134.
- [6] J. Sadowski, T.Szykowny, Determination of the dynamic fracture resistance parameters of metallic materials, Acta Metallurgica Slovaca, Vol.7, No 3 (2001), 454-459.
- [7] J. Sadowski, T.Szykowny, Assessment of cracking for a casting materials in aspect of the criteria of fracture mechanics, Acta Metallurgica Slovaca, Vol.8, No 2 (2002), 412-418.
- [8] M. Biel-Gołaska, A method of testing the dynamic fracture toughness of materials characterized by high plasticity.

- Metallurgy and Foundry Engineering, 1993, Vol.19, No 4, 491-499.
- [9] M. Holzmann, Aplikace mechaniku lomu pro hodnoceni lite oceli a litany., Slevarenstvi 1986, Vol.34, No 5, 194-197.
- [10] J. Sadowski, Analysis cracking process choice casting alloyes subjected a impact bend test, Archives of Foundry, Vol.4, No 12, 2004, 167-179.
- [11] J. Sadowski, T.Szykowny, Analysis of cracking process choice weld joints subjected a impact bend test, Materiały III Sympozjum Mechaniki Zniszczenia Materiałów I Konstrukcji, 2005, 343-348.
- [12] L. Gołaski, Elements of experimental fracture mechanics, Wyd.Politechniki Świętokrzyskiej, Kielce, 1992.
- [13] A. Naimitz, Basics of fracture mechanics, Wydawnictwo Naukowo-Techniczne, Warszawa, 2003.
- [14] J. Sadowski, The evaluation of dynamic cracking resistance of welded joints in the aspect of the impact bending test. Doctoral dissertation, Politechnika Gdańska, 1997.
- [15] ASTM E 24.03.03. Proposed standard method of test for instrumented impact of precrackerd charpy specimens of metallic materials, Draf.2C, Philadelphia, 1989.
- [16] BS6729, British standard method for determination of the dynamic fracture toughness of metallic materials, London BSI, 1988.
- [17] E. Ranatowski, J.Sadowski, Physical and structural characterization of mismatched welded joints by dynamic fracture toughness test, Inżynieria Materiałowa, No 5, 2001, 753-757.
- [18] T. Kabayashi, Evaluation of dynamic crack initiation and growth toughness by computer aided Charpy impact testing system, Nuclear Engineering and Design, 1989, 27-33.
- [19] T. Kobayashi, Evaluation of dynamic fracture toughness parameters by instrumented Charpy impact test. Engineering Fracture Mechanics, 1986, No 5, 773-782.