

Design, fabrication and testing of a cassava pelletizer

O.B. ODUNTAN¹, O.A. KOYA², M.O. FAVORODE²

¹*Department of Agricultural and Environmental Engineering, Faculty of Technology, University of Ibadan, Ibadan, Nigeria*

²*Department of Mechanical Engineering, Faculty of Technology, Obafemi Awolowo University, Ile-Ife, Nigeria*

³*Department of Agricultural and Environmental Engineering, Faculty of Technology, Obafemi Awolowo University, Ile-Ife, Nigeria*

Abstract

ODUNTAN O.B., KOYA O.A., FAVORODE M.O., 2014. **Design, fabrication and testing of a cassava pelletizer.** Res. Agr. Eng., 60: 148–154.

This paper reports on the design of fabrication and testing of a machine for cottage level production of pellets from cassava mash. The pelletizer consists of a barreled screw auger which compresses cassava mash against perforated end plate, through which the pellets are pelletized. The result derived from the calculated design parameters (shaft diameter, tensile stress, torque, screw length, volumetric capacity mass flow rate and power rating) were used for the fabrication. The testing of the pelletizer was determined in terms of throughput of the machine, against the moisture content of the mash (18, 20 and 22% w.b.), die size (4, 6 and 8 mm) and the auger speed (90, 100 and 120 rpm). Test results showed that the pellets with the best quality attributes were obtained from cassava mash at 18% moisture content (w.b.) through the 4 mm die at 90 rpm and a maximum throughput of 54 kg/h.

Keywords: pellets; machine; throughput; moisture; speed

Cassava (*Manihot esculenta*), an important root crop in Sub-Saharan Africa is a carbohydrate staple food that provides energy for about 500 million people in the world. It is also the third most important food source in the tropics after rice and maize (COCK 1985). It derives its importance from the fact that its starchy, thickened, tuberous roots are a valuable source of cheap calories especially in developing countries where calories deficiency and malnutrition are widespread. In many parts of Africa the leaves and tender shoots of cassava are also consumed as vegetables (KROCHMAL, HAHN 1991). Cassava production in Nigeria is by far the largest in the world; a third more than production in Brazil and almost double the production of Indonesia

and Thailand. Cassava production in other African countries, the Democratic Republic of the Congo, Ghana, Madagascar, Mozambique, Tanzania and Uganda appears small in comparison to Nigeria's substantial output. An estimate of annual production of cassava in Nigeria was reported to be approximately 34 million tons (ASHAYE et al. 2005).

Global production of cassava tubers and the post-harvest processing activities have been on the increase in the last 20 years. The products from cassava tuber are prepared for human and animal consumption and industrial use, but with growing emphasis on animal consumption and industrial use. Until recently, about 85% of the world production of cassava was consumed by man. The remain-

ing 15% was shared between animal and chemical industries (ADEEKO, AJIBOLA 1990).

ASHAYE et al. (2005) reported that the tuber is best administered in pelletized form, when it must be fed, or compounded with other ingredients, as animal feed. Compounding cassava with other ingredients for livestock feeds has gained wide practice in Latin America, Asia and the European Union. The substitution of wheat flour partially with cassava flour and production of cassava chips and pellets for animal feed are other areas of utilization with some potential significant in Nigeria. The pellets also have better keeping quality and required less storage space compared to raw tubers (HRISHI 1974).

Pelletization is often referred to as expander treatment (PEISKER 1992). In principle, expander treatment is related to the extruder treatment (PRESTLOKKEN 1999). The feed material enters a feed barrel through an inlet gate. A screw conveyor driven manually or by electrical motor forces the feed material towards a resistor in the outlet gate, the pressure immediately drops to atmospheric. The release of pressure and spontaneous evaporation of water makes the feed material expand in volume and the temperature to drop rapidly. The temperature can rise to high levels, but the entire process is usually completed within seconds.

Over time, series of processing equipment at different levels of sophistication were imported into Nigeria for the pelletization process (PABIS, JAYAS 1998). Major problems associated with such machines included high initial and maintenance costs, requirement for highly skilled maintenance engineering staff and dependency on expensive infrastructure facilities. On the other hand, it is arguable that local manufacture of machines is both technically and economically feasible in Nigeria (ODIGBOH 1985). In this direction, previous designs have employed complex technological processes, mimicking the imported versions (KWATAI 1986). Consequently, the pelletizing plant remained capital intensive and prohibitive for the class of small and medium scale investors. Therefore, the development of versions of simply designed pelletizer should be seen as technological development to satisfy a niche market in the industry. Thus, this work was conceived in the search for a simple technology to process cassava flour to pellets using locally available materials. Hence, the main objectives of this work were to design, fabricate and testing of the pelletizer.

MATERIAL AND METHODS

Design philosophy. The machine was conceived in the search for a simple technology, easy to operate and easy to fabricate motorized operated device capable of processing cassava flour to pellets using locally available material.

Machine description. The pelletizer is basically a combination of auger and die. A helical auger is mounted on a conical shaft which is supported by bearing so that the shaft rotates in the stationary cylindrical barrel. The orthographic view of the pelletizer is show in Fig. 1. The pelletizer consists of the following parts: the barrel, a shaft on which is welded the auger, the hopper, heat exchanger barrel, the bearing, gear and the frame. Each component was designed following standard engineering principle. A blended mash of cassava is introduced into auger through the inlet gate of the barrel. The auger conveys material to the die and builds up pressure for extension. Pressure resulting from rotating auger forces the mash through the perforations in the die, compressing and forming it into pellet. The pellets were allowed to break off by force of gravity. Consequently, sizing was random, but further handling eliminated excessively long particles.

Preliminary investigation. Cassava tubers were obtained from a local farm in Ibadan, Nigeria. The tubers were washed, peeled with knife, grated and dried into cassava flour. The proximate analysis of the cassava flour at the time of the experiment was determined using standard methods. Each experimental run was replicated three times.

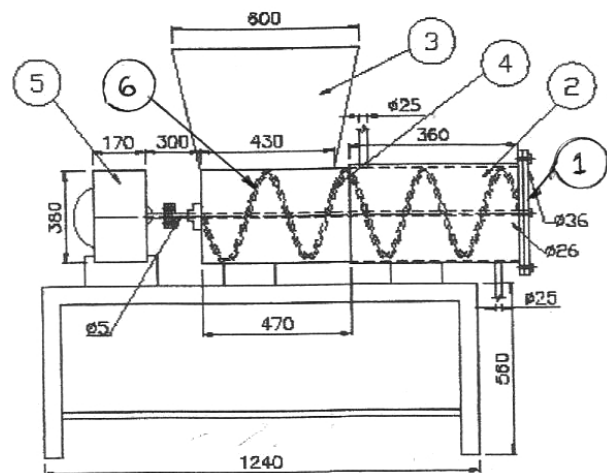

Fig. 1. An orthographic drawing of machine

1 – die plate, 2 – heat exchanger barrel, 3 – hopper, 4 – main barrel, 5 – gear box, 6 – screw

A laboratory press (LP; OAU, Ife, Nigeria) was used for pressing operation in the view to determine the pressure at which the mash will turn to pellet. Extrusion point of the mash was identified by using the method adopted by AJIBOLA et al. (2000, 2002), and SUKUMARAN and SINGH (1989) on sesame seed, soybean, and locust bean, respectively. The cylinder containing the sample was placed under the compression piston. Known weight was added to the loading drum while the lever arm was suspended by the hydraulic jack. The jack was released gently to allow the suspended lever arm to lower down gradually to rest on the pressing ram and compression piston. The pressure generated was transferred through the cylinder onto the mash. The jack was then used to lift the lever arm in order to remove the cylinder and piston. After each pressing operation, the pellets were collected from the die holes fixed to cylinder and quantity examined (which was an indicator whether the pressure at that point due to the load was sufficient to produce pellets out of the mash or not). The distance from this point to the support was measured and converted to pressure using the principle of moment of forces. Each experimental run was replicated three times.

Design of machine component. The investigated parameters for the design include shaft diameter, tensile stress, torque, volumetric capacity, mass flow rate, screw length and machine power requirement. Equations (1) to (7) were used to calculate some of the parameters for the various components (ADEEKO, AJIBOLA 1990; FRAME 1994).

The max. shear theory is a function of yield stress and factor of safety:

$$\tau_{\max} = 0.5\tau_{ys}/f_s \quad (1)$$

where:

τ_{\max} – max. shear (N/m²)

τ_{ys} – yield stress (N/m²)

f_s – factor of safety (fraction)

The torque is a function of max. shear and diameter of the shaft:

$$T = \tau_{\max} \pi d^3 / 16 \quad (2)$$

where:

T – torque (Nm)

τ_{\max} – max. shear (N/m²)

d – diameter of the shaft (m)

Screw length calculation is a function of the equations of a helix, wound on a tapered shaft:

$$S = 3.42(r + ml)\theta_2 \quad (3)$$

where:

S – screw length (m)

r – radius of shaft (m)

l – length of shaft (m)

m – tangent of tapering angle (rad)

θ_2 – helix angle (rad)

The volumetric capacity of a screw is a function of the screw speed, diameter and distance between flights of the screw:

$$Q_v = \pi d^2 H_p N \quad (4)$$

where:

Q_v – conveying volume (m³/s)

d – diameter of screw (m)

H_p – pitch (m)

N – screw speed (r/min)

The required diameter for solid shaft with little or no axial loading but having combined bending and torsional loads, is obtained as:

$$D^3 = (16 / \pi \sigma_s) \sqrt{\{(K_b M_b)^2 + (K_t M_t)^2\}} \quad (5)$$

where:

D – diameter shaft (m)

σ_s – allowable stress (N/m²)

K_b – shock and fatigue factor applied to bending moment

M_b – max. bending moment (Nm)

K_t – shock and fatigue factor applied to torsional moment

M_t – max. torsional moment (Nm)

The volumetric flow rate is a function of pressure drop and viscosity:

$$Q = k_d (\rho_d / \mu_d) \quad (6)$$

where:

Q – volumetric flow rate (m³/s)

ρ_d – total pressure drop (N/m²)

μ_d – dough viscosity at the die (Pa·s)

k_d – die constant (fraction)

Die constant for a die of circular cross-section:

$$k_d = \tau R^4 / 8L_D \quad (7)$$

where:

τ – shear stress (N/m²)

R – nozzle radius (m)

L_D – land length of die (m)

From the design calculation, the machine is capable of taking 10 kg of the mash at once through

the hopper to the screw before pelleting the mash. The shaft diameter was calculated to be 44.5 and 50 mm, obtainable in the market, was used during fabrication. Tensile stress, torque, screw length of 56 MN/m², 159.16 Nm and 0.83 m, respectively, is required. The volumetric capacity and the mass flow rate were calculated to be 0.198 m³/s and 158.08 t/h. The machine power requirement was calculated as 7.31 kW of which 7.5 kW was used for the construction of the machine. The die plate hole for the three plates was drilled using the calculated land length of the die opening of 6.25 mm.

Construction of the machine

Barrel. The barrel was a pipe, made of mild steel, the inside diameter of which was 260 mm. A slot 230 × 430 mm was cut into the barrel. It was through this slot that the cassava mash was admitted into the barrel from the hopper. Two flanges of 260 mm inside diameter and outer of 300 mm were welded next to the hopper and 360 mm away, respectively. It was between these flanges that a barrel with 300 mm inside diameter and 360 mm long, forming the heat exchanger was introduced.

Auger. A 50 mm shaft was overlaid with a screw conveyor of height 180 mm, pitch 160 mm and over a length of 856 mm (Table 1). The auger was equipped with an intermediate stepped pulley drive, allowing the possibility to change speed easily by changing a belt, without installing frequency controllers. The auger was designed to be compact in cross-section, is one-way. The mash placed moved along its length in smooth spiral motion by the rotation of the screw which is supported by intermediate pillow bearing of diameter 45 mm.

Table 1. Major components of the cassava pelletizer

Component	Dimension
Base diameter of screw shaft	50 mm
Max. diameter of screw shaft	255 mm
Shaft length	856 mm
Length of taper	8 mm
Angle of taper	1.5°
Pitch	160 mm
Length of barrel	830 mm
Inner diameter of barrel	260 mm
Heat exchanger barrel diameter	360 mm
Rotation speed	90–120 rpm
Power rating of electric motor	7.5 kW

Hopper. The hopper was made from a mild steel sheet of 2 mm thickness. It was designed based on the bulk density of mash. It was a rectangular bin hopper, 60° centre draw-off, about 600 × 600 mm at the top and 230 × 430 mm at the narrow end. The hopper was welded to the barrel at the slotted opening that admits the cassava mash into the barrel.

Pellet die. The pellet die is the heart of the pellet forming operation. In the pellet press, cassava mash is converted to pellets when the mash is pushed through the holes of the die. Consequently, a set of three dies, each 360 mm in diameter and 10 mm thick were used. The terms that are most important when selecting a pellet die are holes diameter (*d*); typical holes diameters range from 2.38 to 19.05 mm (PRESTLOKKE 1999). Die with 4, 6 and 8 mm hole diameters were chosen for this design.

Frame: The frame is made of angle iron, 75 × 75 × 8 mm in cross section. The frame is 1,240 mm long, 400 mm wide and 560 mm high. Other assemblies such as the bearing mountings hopper assembly, barrel, screw, electric motor and gear were mounted on the frame.

Power transmission system. A 7.5 kW, three phase electric motor was used as the prime mover for the pelletizer. The motor was mounted at the side of frame assemble on two rails. The provision of rails facilitates the motor movement in the horizontal direction for adjusting the belt tension. Three step pulley of 200, 240, and 264 mm diameter was connected to another three grooves pulley of diameter 80 mm on the electric motor of 1,500 rpm. The three step pulley was connected to the reduction gear box of ratio 1:5. The speed of the motor was reduced to three different speeds (454, 500 and 600 rpm) through the step pulley and speed was further reduced to 90, 100, and 120 rpm by the reduction gear box.

Performance test procedure. The performance of the pelletizer in producing whole pellets was evaluated on the basis of the quantity of recovered at various speeds of the shaft and the die size. The pelletizer was run at different speeds by changing the diameter of the drive pulley to achieve 90, 100 and 120 rpm. The dozing of the mash at different blend (cassava: water) ratio were kept constant at 10 kg per batch (ALVES et al.1999). The pellet recovery was assessed on the basis of the uniform thickness of the pellet without major breakage. The weight of the pellets with lengths ranging between 4 and 16 mm extruded in a time frame of 10 min was determined.

Table 2. Proximate analysis of the cassava flour

Component	Reference	Cassava flour
Moisture (% d.b.)	ASABE Standard D269.4 (2003)	10.35 (0.81)*
Ash (% d.b.)	ASTM Standard D5142 (2004)	3.89 (0.25)
Fat (% d.b.)	ASTM Standard D5373 (2002)	2.04 (0.05)
Crude protein (% d.b.)	ASTM Standard D5373 (2002)	2.10 (0.10)
Crude fibre (% d.b.)	ASTM Standard D5373 (2002)	2.31 (0.09)
Gross energy (kcal/g)	ASTM Standard D5865 (2004)	3.10 (0.01)
HCN (mg/kg)	ASTM Standard D5373 (2002)	4.76 (0.16)

*values are means of triplicate and numbers in parentheses are standard deviation; d.b. – dry base; HCN – hydrogen cyanide

The throughput capacity of the pelletizer C_T was however determined by Eq. (8):

$$C_T = W_p / T \quad (8)$$

where:

W_p – average weight of the pellet collected after palletisation (kg)

T – average palletisation time (h)

All measurements were carried out in triplicate. Statistical analysis and equation fitting using appropriate procedures in SAS statistical software package (SAS 2005; Institute Inc., Cary, USA) were performed on all data.

RESULTS AND DISCUSSION

Proximate analysis

The data obtained from the proximate analysis of the cassava flour are summarized in Table 2. The average moisture content of the cassava flour during the experiment was 10.35% (w.b.) and the average crude fibre was 2.31% (with standard deviation of 0.09%).

Pellet extrusion pressure

A summary of the average pellet extrusion pressure for cassava mash at different expression conditions (moisture content) is presented in Table 3. The mean values of extrusion pressure for cassava mash lie between 0.19 and 0.38 MPa. Generally, the results showed that extrusion pressure decreases with increase in moisture content of the cassava mash. This is in agreement with findings of FRAME (1994).

Effect of die sizes, speed and mash moisture level on the throughput of the machine

The result of the 3^3 factorial experiments is shown in Table 4 and Fig. 2. Comparing the estimates with their Standard Errors, it was observed: that the lubricating effect from high moisture of mash might explain the higher throughput value of 62.4 kg/h at 20% (w.b.) which was extruded at 120 rpm using 6 mm die and of 67.2 kg/h at the same 20% (w.b.) extruded at 120 rpm using 8 mm die. This is in agreement with findings in preliminary experiment.

Operating the machine at the higher speed with 8 mm die brought out a higher throughput value of 67.2 kg/h. This observation appears reasonable since WOOD (1997) revealed that the output rate of the pellet press increases with the pre-gelatinized starch content, and the speed of the machine did not only exposed the mash to the highest temperature but also to the highest level of shear.

The result of the study showed that speed, die and moisture content of the mash were significant ($P \leq 0.05$), affected the throughput of the machine (Table 4) with the die sizes. This suggests improved

Table 3. Point pressure of cassava mash under different moisture content conditions

Moisture content (% w.b.)	Mean value of the point pressure (MPa)
16	0.3822 (0.0044)*
18	0.3137 (0.0049)
20	0.2461 (0.0052)
22	0.2122 (0.0045)
24	0.1845 (0.0051)

*values are means of triplicate and numbers in parentheses are standard deviation; w.b. – wet base

Table 4. Summary of ANOVA on the effects of speed, MC and die on the throughput

Source of variation	Degree of freedom	Sum of squares	Mean square	F	P > F
Die	2	8.17950617	4.08975309	5.74	0.0055
Speed	2	20.44543210	10.22271605	14.35	< 0.0001
Die × speed	4	1.66419753	0.41604938	0.58	0.6754
MC	2	19.32172840	9.66086420	13.56	< 0.0001
Die × MC	4	6.37456790	1.59364198	2.24	0.0770
Speed × MC	4	7.90419753	1.97604938	2.77	0.0360
Die × speed × MC	8	3.59061728	0.44882716	0.63	0.7488
Error	5				

P – P-value; F – F statistic; MC – moisture content

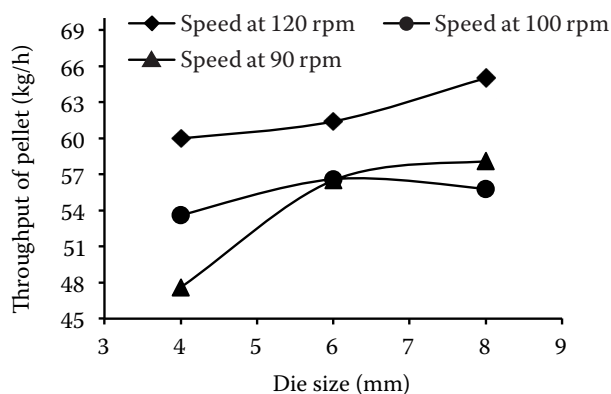

Fig. 2. Effect of die size on the throughput of the machine at 20% moisture content (% w.b.) pelletized at various speeds and die sizes

pellet quantity with increasing pelletizer temperature.

The observed machine efficiency was found to be higher (96%) for pellet; pelletized using 8 mm die with moisture content of mash at 18 and 20% (w.b.), while the machine was driven at 120 rpm. It shows that efficiency increased with increase in die sizes and highly correlated with auger speed since lower (55.7%) efficiency was recorded using 4 mm die at 90 rpm. Actually, pelletizer efficiency strongly depends on the material being processed and its moisture content (FASINA 2008). Also, a pelletizer cannot be expected to run at 100% efficiency, since the pelletizer is not completely adiabatic and the system itself consumes power, plus the external energy consumption.

CONCLUSION

The effect of speed, die and moisture content of the mash significantly ($P \leq 0.05$) affected the

throughput of the machine. The extrusion pressure decreased with increase in moisture content of the cassava mash. The pellets with the best quality attributes were obtained from cassava mash at 20% moisture content (w.b.) extruded through the 4 mm die at 90 rpm and a max. throughput of 54 kg/h.

The efficiency increased with increase in die sizes and highly correlated with auger speed since lower (55.7%) efficiency was recorded using 4 mm die at 90 rpm. The pelletizer cannot run at 100% efficiency, since the pelletizer is not completely adiabatic. The machine described above is simple and safe. It produces more uniform circular shaped pellets. It can be used by small farmers as well as small-scale processing industries.

References

- ADEKO K.A., AJIBOLA O.O., 1990. Processing factors affecting yield and quality of mechanically expressed groundnut oil. *Journal of Agricultural Engineering Research*, 45: 31–43.
- AJIBOLA O.O., ADETUNJI S.O., OWOLARAFE O.K., 2000. Oil point pressure of sesame seed. *Ife Journal of Technology*, 9: 57–62.
- AJIBOLA O.O., OKUNADE D.A., OWOLARAFE O.K., 2002. Oil point pressure of soybean. *Journal of Food Process Engineering*, 25: 407–416.
- ALVES R.M., GROSSMAN, M.V.E., SILVA R.S.S.F., 1999. Gelling properties of extruded yam (*Dioscorea alata*) starch. *Food Chemistry*, 67: 123–129
- ASHAYE O.A., COUPLE A.A., FASOYIRO S.B., ADENIJI A., 2005. Effect of location and storage environment on the quality attributes of gari in South-Western Nigeria. *World Journal of Agricultural Sciences*, 1: 52–55.
- ASABE Standard S269.4, 2003. Cubes, pellets and crumbles-definitions and methods for determining density, durability, and moisture content. St. Joseph, ASABE.

- ASTM Standard D5373, 2002. Test methods for instrumental determination of carbon, hydrogen and nitrogen in laboratory samples of coal and coke. West Conshohocken, ASTM International.
- ASTM Standard D5142, 2004. Test method for proximate analysis of sample of coal and coke by instrumental procedures. West Conshohocken, ASTM International.
- ASTM Standard D5865, 2004. Test method for gross calorific value of coal and coke. West Conshohocken, ASTM International.
- COCK J.H., 1985. Cassava – New Potential for Neglected Crop. Westview Press, Boulder and London: 23–52.
- FASINA O.O., 2008. Physical properties of peanut hull pellet. *Journal Bioresource Technology*, 99: 1259–1266.
- FRAME N.D., 1994. *The Technology of Extrusion Cooking*. New York, Blackie Academic and Professional.
- HRISHI N., 1974. Problems and prospects of cassava production in India. Cassava processing and storage. In: *Proceedings of an interdisciplinary workshop*, April 17–19, 1974, Pattaya, Thailand. International Development and Research Centre, IDRC-031e: 59–62.
- KROCHMAL A., HAHN S.K., 1991 Tropical root crop in a developing economy: Proceeding of the 9th Symposium of the International Society for Tropical Root Crops Accra, Ghana.
- KWATAI J.T., 1986. *Rural Cassava Processing and Utilization Centre UNICEF/IITA Collaborative Program for Household Food Security*. Ibadan, Lidato Press.
- ODIGBOH E.U., 1985. *Mechanization of cassava production and processing: A decade of design and development*. University of Nigeria Inaugural Lecture, Series No. 8.
- PABIS S., JAYAS D.S., 1998. *Grain drying Theory and Practice*. New York, John Wiley.
- PEISKER M., 1992. Improving feed quality by expansion. *International Milling Flour & Feed*, March: 15–20.
- PRESTLOKKEN E., 1999. Protein value of expander-treated barley and oats or ruminants. [PhD. Thesis.] Agricultural University of Norway: 142.
- SUKUMARAN C.R., SINGH B.P.N., 1989. Compression of bed of rape seed; the oil point. *Journal of Agricultural Engineering Research*, 42: 77–84.
- WOOD J.F., 1997. The functional properties of feed raw materials and their effect on the production and quality of feed pellets. *Animal Feed Science and Technology*, 18: 1–17.

Received for publication November 1, 2012

Accepted after corrections May 20, 2013

Corresponding author:

Eng. OLUWAFEMI B. ODUNTAN, University of Ibadan, Faculty of Technology,
Department of Agricultural and Environmental Engineering, Ibadan Oyo 200284, Nigeria
phone: + 234 (0) 803 327 2525, e-mail: femkem03@yahoo.co.uk
