

# Application of smart sensors in the measurement of soil physical parameters

W. SKIERUCHA, A. M. WILCZEK, R. T. WALCZAK

*Institute of Agrophysics, Polish Academy of Sciences, Lublin, Poland*

**ABSTRACT:** The study presents the project and partial implementation of a modern monitoring system for the measurement of soil physical parameters. It is provided with smart sensors equipped with signal conversion electronics, individual identification and communication means decreasing the complexity of the measurement system and also the measurement errors that can appear during analog signal transmission along the cables from the sensors to the measuring unit. The applied wireless communication system operates in the 433 MHz ISM (Industrial, Scientific, Medical) licence free frequency band for transmission of commands and data between a remote PC compatible computer (Master unit) and the smart sensors (Slave units) in the distance of several hundred meters. The presented partial implementation of the system measures the temperature at several locations in the soil profile in field conditions and communicates with the host PC computer in wireless way. The developed hardware and software is intended to be adapted to more complex monitoring systems working in compliance with IEEE 1451 smart transducer interface standard and covering large areas as an element of air-borne or satellite remote sensing and serve for ground reference measurements. It is shown that the currently available technical means enable to apply smart sensors and wireless communication in the environmental monitoring in the economically justified way. The small increase of the system price by providing the measuring smart sensors, already equipped some element of control or computation, with radio communication assures the decrease of measurement errors and makes the collection of environmental data convenient for the system operator.

**Keywords:** smart sensor; monitoring; modelling; wireless network; agrophysics

A sensor is the portion of a measurement system that responds directly to the physical variable being measured (FIGLIOLA 1999) such as thermal energy, electromagnetic energy, acoustic energy, pressure, magnetism, or motion by producing quantitative, usually electrical signals. Sensors are input devices of the measurement system while actuators are output devices translating electrical signals into usually mechanical actions. Transducers are defined as devices that convert one type of energy to another, for example temperature to an electrical signal. A sensible distinction is to use 'sensor' for the sensing element itself and 'transducer' for the sensing element plus any associated circuitry. All transducers would thus contain a sensor and most (though not all) sensors would also be transducers.

Smart transducers must incorporate some element of control, computation or decision-making. They enhance functionality, performance or cost of the measurement system.

Sensors and actuators are everywhere: at home appliances, in the office, in factories etc., and they are intended to increase the control of human environment, increase production efficiency and enhance our security. Because of the inherent intelligence smart sensors implementation would give many advantages as compared to standard sensors, e.g.:

– self-test and self-calibration,

- increased accuracy of the measurement by minimizing analog signal wire transmission,
- remote programmability, digital communication, networked wireless and WEB based remote monitoring and control,
- implementation of Plug-and-Play features.

## Smart sensors and smart sensor interfaces

The driving forces that develop smart sensor technology are mainly: aerospace, automotive and military industries, industrial control and automation, building automation, security and also environmental monitoring.

Currently there are two ways for the development of smart sensing technologies (WICZER 2001). The first one represents basic physical and (bio) chemical research in sensor's conversion phenomena: thermoelectric, photoelectric, photomagnetic, electromagnetic, thermooptic, etc. in the context of integrating the sensing element with microelectronic-based "smart" capabilities. The problems facing researchers in this field concern selectivity, materials compatibility and integration of different technologies. The example of technology and material incompatibility is a thermocouple operating at temperatures 300 °C to 50° C enhanced by "smart" microelectronic element. The most microelectronics circuits do not work at temperatures above 150 °C and the ma-

---

Supported by the Polish State Committee for Scientific Research, Research Project 2 P04G 032 26.

materials used to manufacture thermocouples are generally not compatible with high purity conditions of silicon based microelectronics fabrication process. Other example is the Micro-Electro-Mechanical System (MEMS) that integrate mechanical elements, sensors, actuators, and electronics on a common silicon substrate through micro-fabrication technology. The successful applications of MEMS sensors are: pressure transducers integrated with analog signal processing circuits and digital interfacing circuits, accelerometers available in the form of integrated circuits. Apart from technical obstacles there are also economical reasons that hamper the wide implementation of integrated smart sensors, i.e. users and producers implementation costs as well as the lack of widely accepted standards.

Use of smart interfaces is another way for implementing smart sensor technologies. Smart interfaces allow moving technology specific sensor elements from microelectronics of analog signal conditioning, conversion, digital signal processing and communication to enhance existing sensors with intelligence by means of smart interfaces (WICZER 2001). This solution enables to use existing sensors the users are accustomed to, and do not force the sensor producers to sometimes expensive research in solving technology and material incompat-

ibilities. A set of standards under development, aimed to simplify sensors connectivity is coordinated by National Institute of Standards and Technology (NIST) and is adopted by Institute of Electrical and Electronics Engineers (IEEE) under the name IEEE 1451 (LEE 2003).

The purpose of IEEE 1451 standards (<http://ieee1451.nist.gov>) is to define a set of common interfaces for connecting transducers to microprocessor-based systems, instruments and field networks in a network-independent fashion. The IEEE 1451 standard include five complete sub-standards. The IEEE 1451.1 and 1451.2 have been published and accepted by the IEEE. The sub-standards IEEE P1451.3, IEEE P1451.4 and IEEE P1451.5 are in progress, which is denoted by the letter "P". The IEEE 1451.1 defines the way the transducers are connected by a Network-Capable Application Processor (NCAP) to networks such as Ethernet. This standard supports all of the interface module communication with transducers used by the rest of the IEEE 1451 family. IEEE 1451.2 standard defines point-to-point digital communication between a Smart Transducer Interface Module (STIM) and the NCAP (Fig. 1) by means of a Transducer Independent Interface (TII). The STIM contains a Transducer Electronic Data Sheet (TEDS) with information (the manufacturer data, and the optional calibration

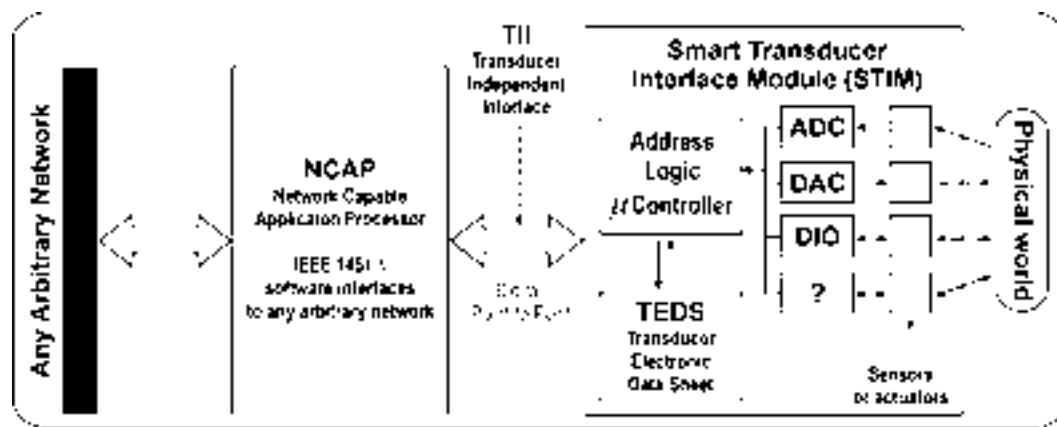

Fig. 1. IEEE 1451.2 standard of digital point-to-point system interface, ADC-Analog to Digital Converter, DAC-Digital to Analog Converter, DIO-Digital Input/Output

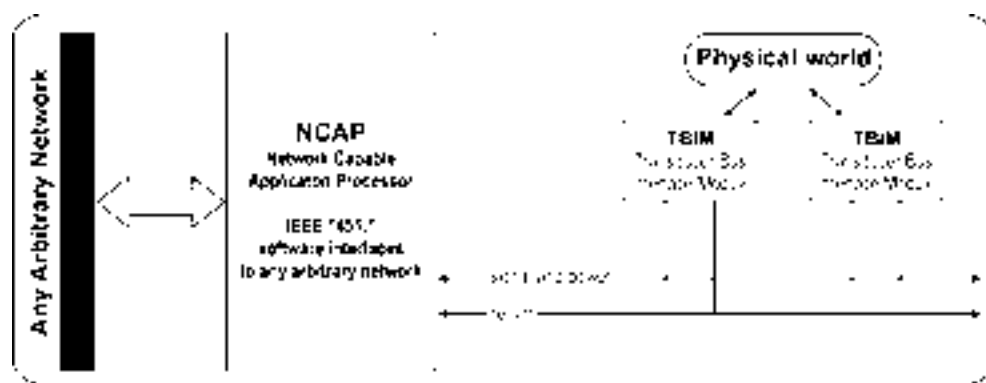

Fig. 2. IEEE P1451.3 proposed standard of the digital multidrop system interface

and correction data) in standardized format about every transducer connected. TEDS is always attached to the transducer and its content is electronically transferred to NCAP or a host computer connected to the arbitrary network, thus the human errors associated with manually entering sensor parameters are avoided and Plug-and-Play features can be implemented.

The IEEE P1451.3 standard is designed for distributed multidrop smart sensor systems, where a large amount of sensors need to be read in a synchronized manner. In some cases it is not possible to locate the TEDS with the transducers, as it is accomplished in the IEEE 1451.2 standard, for instance due to harsh environment. The physical representation of the proposed IEEE P1451.3 standard is presented in Fig. 2. A single transmission line is intended to supply power to the transducers and to provide the communication between the bus controller located in NCAP and the Transducer Bus Interface Modules (TBIM). A transducer bus is expected to have one bus controller and many TBIMs, and a TBIM may contain one or more different transducers.

The proposed standards IEEE P1451.4 and IEEE P1451.5 are intended for: mixed-mode (analog and digital) communication and wireless communication protocols, respectively.

### Measurement systems in Agrophysics

The example of quantitative evaluation of agrophysical processes will be discussed on the example of the soil solid phase. Similar discussion can be done for other porous media and related processes in Agrophysics.

Soil physical parameters change continuously for climatic reasons and human activity. Mineral composition, grain distribution and humus content are practically not affected by spatial and temporal change. Human activity: organic and chemical fertilization, as well as mechanical influence modify the variable parameters of the soil solid phase including: organic matter content, aggregate distribution and soil compaction. The basic quantities describing the soil physical status in the quantitative way are: soil water content and potential, soil temperature, mechanical properties (texture and poros-

ity), gas diffusion, salt concentration and ions activity (Fig. 3).

The selected field sensors used to determine the basic soil solid phase by means of direct or indirect indicators are:

- water content and potential: TDR moisture probes, capacitive probes, neutron scattering probes, gypsum blocks, tensiometers, thermocouple psychrometers;
- temperature: semiconductor, thermocouple and mercury thermometers, heat flux sensors (soil thermal conductivity measurement);
- mechanical properties: penetrometers, density and texture measurement require laboratory equipment;
- diffusion of gases: redox potential meter, ODR – platinum electrodes;
- salt concentration and ions activity: soil electrical conductivity sensors, ion selective electrodes.

The most important soil physical property for the monitoring, directly influencing the others, is soil water content. A very promising method for soil moisture determination is based on Time Domain Reflectometry – TDR (TOPP et al. 1980; MALICKI, SKIERUCHA 1989; MALICKI et al. 1996; MALICKI, WALCZAK 1999; SKIERUCHA, MALICKI 2002). Its methodology and measurement equipment including TDR soil moisture sensor has been developed in the Institute of Agrophysics Polish Academy of Sciences (IAPAS) since 1985. Also the concentration of selected ions in the soil giving the information about its fertility and/or intoxication seems to be of major concern. Research on the application of ion selective electrodes in three-phase medium has recently become the research subject of IAPAS.

### MATERIAL AND METHODS

The measurement system under development in IAPAS is intended to work in compliance with IEEE 1451.3 standard of digital multidrop system interface (Fig. 2). Also it will accomplish some elements of wireless communication (IEEE 1451.5). The schematic description of this system is presented in Fig. 4.

The main element of the system is the NCAP for communication with the Ethernet network from one side

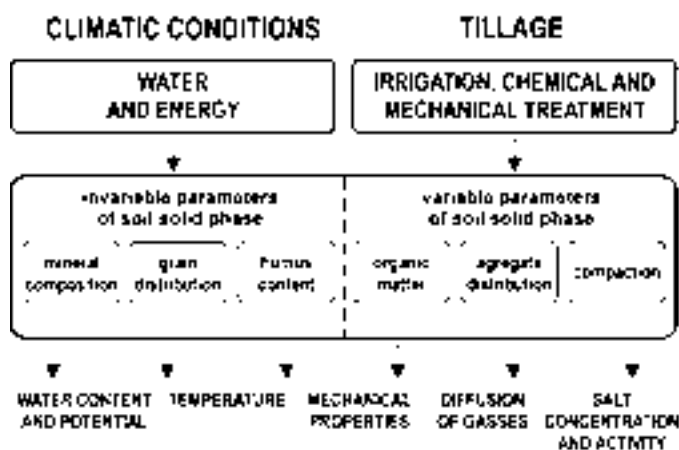

Fig. 3. Factors influencing invariable and variable parameters and physical quantitative indicators of soil solid phase

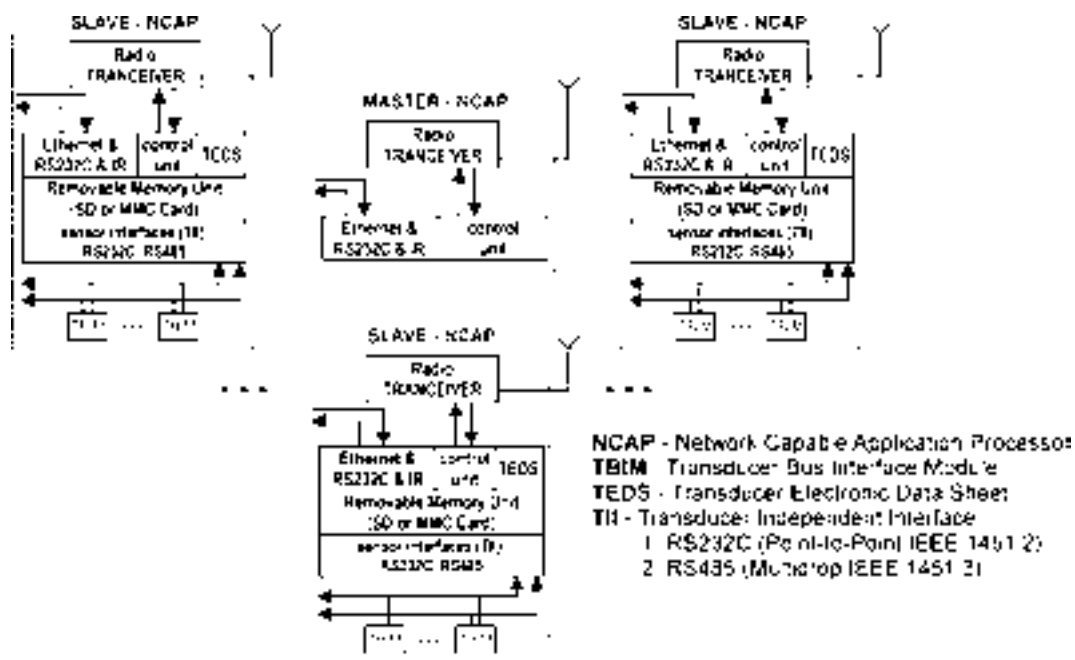

Fig. 4. System under development in IAPAS for the measurement of agrophysical properties, working in compliance with the IEEE 1451 standard

and the transducers from the other side. NCAP may work as a MASTER or SLAVE unit, both based on the same electronics, but the MASTER unit serves only as an interface between multiple SLAVES and the Ethernet network, without the ability to manage transducers (sensors or actuators). The transducers are connected to the SLAVES by means of a digital multidrop system interface constructed on the hardware base of a serial RS485 interface, serving as a small and cheap TBIM that fits easily into a transducer. For the purpose of compatibility with old versions of sensors and instruments developed in IAPAS there is also RS232C asynchronous serial interface for digital point-to-point communication, like in the IEEE 1451.2 standard. In the case of multiple SLAVES they communicate with the MASTER unit by means of wireless communication using 433MHz ISM (Industrial, Medical and Scientific) licence free frequency band. Each SLAVE has a large amount of non-volatile memory, for the storage of data collected from transducers, in the form a popular and not expensive removable Security Digital (SD) or MultiMedia Card (MMC). The information about the connected transducers is stored in TEDS being a part of the microprocessor unit.

The main technical features of the soil physical parameters monitoring system with wireless communication link are as follows:

- radio communication in the license-free ISM (Industrial, Scientific and Medical) frequency bands 433 MHz,
- the hardware and software of the communication system is designed with the following major criteria:
  - minimize the transmission errors,
  - maximize the radio link range,
  - minimize the current consumption (SLAVES are battery operated),

- each SLAVE device has facilities to connect it directly to the Ethernet network, as a Plug-and-Play device, with unique identification parameters (TEDS),
- sensors, smart sensors-transducers, measuring devices from various vendors (i.e. TDR units, tensiometers, temperature sensors, etc.) are connected to the SLAVES by the sensor interfaces,
- SLAVES are equipped with memory cards (Secure Digital or MultiMedia Cards) to store collected data (memory capacity is up to 128 MB).

Basic functional features of the wireless communication system:

- MASTER device works as a converter of radio data 433 MHz (other frequencies in ISM bands: 868 MHz and 2.4 GHz are planned for implementation) to Ethernet data accessible from any personal computer (PC) connected to Internet. It mediates between PC computer and SLAVE devices in data and commands transfer.
- The SLAVE device executes commands from a text script file stored in a memory card. After execution the last command in the script file, the sequence starts from the first command.
- The commands in the script file allow the SLAVE to:
  - change the parameters of the serial interfaces,
  - send commands and receive data by the sensor interfaces,
  - create an output file in the memory card and store data from the sensors in it,
  - change the format of data output file (insert time or data, number of the script executions, name of the script file executed currently),
  - initiate the sleep mode of the SLAVE (with minimized power consumption) for a fixed time (in seconds).

- Configuration and control of SLAVE device is performed by radio communication (default), Ethernet or serial interface RS232C and it enables to:
  - read the state of the SLAVE device (local real time clock, battery voltage, temperature, free memory card area, number of the script executions, the name of the current script),
  - read whole or partial files from the memory card,
  - write a new script file to the memory card,
  - stop the script execution and start it again,
  - give an unique identification number of the SLAVE.

The application software is an Internet browser (e.g. Internet Explorer or Netscape) running on any PC computer connected to Internet accomplishes the control of the measurement system. The individual IP number and password guard the access to the selected SLAVE.

## RESULTS AND DISCUSSION

The presented system of wireless communication was tested by connecting seven temperature sensors to the SLAVE unit, one of which measured the ambient temperature, the others were placed in the soil at the depths: 5, 10, 15, 20, 30 and 40 cm below the ground level. The SLAVE unit was placed in metal enclosure, protecting the electronics from rain, in a field plot at the distance about 70 m from the building with the PC computer controlling the MASTER unit. Detailed description of the experiment and the wireless communication protocol is presented in WILCZEK et al. (2003).

The experimental setup worked several days measuring and transmitting the temperature data by the radio link. The quality of the link is presented in Fig. 5. Totally there were 2,772 radio connections with 97% performed in the first attempt. Only 3% connections were repeated; 11 1-time, 74 2-times and 1-time the attempt of radio connection had to be repeated 3 times to succeed.

The developed transmission protocol allows 10-times repetitions of sending the data or command frame. If the connection is not established the PC computer registers this event and records it in a text file, and then the system continues the operation. It was experimentally checked that the SLAVE unit worked well enough at

distance about 500 m from the MASTER unit, provided that there was no obstacle (trees, buildings, etc.) between them. In other words the devices have to see one another.

The readouts from the temperature sensors placed on various depths in the soil profile are presented in Fig. 6. As expected, the sensor that measured the ambient temperature had the shortest response time to the temperature change. The deeper the sensor was located, the slowest reaction on the temperature change was observed. Additionally, the reaction of the sensors to temperature changes was shifted in time because of the limited speed of temperature change in the soil profile (WALCZAK 1987).

The main motivation for the measurement system (Fig. 4) design and implementation was the need to modernize the existing monitoring system of soil physical parameters: moisture measured by Time Domain Reflectometry method (TOPP et al. 1980; MALICKI et al. 1996), water potential, salinity, and temperature. Such a system has been manufactured in IAPAS (<http://www.easytest.lublin.pl>) and used in many research centres in the world for soil physical properties analysis. It enables to verify the models of mass and energy transport in the soil in field conditions. Also, it may be applied for analysis of other porous media: building materials, food products, etc. as well as their storage and transportation. Particularly important parameter for monitoring is water content directly influencing the physical and chemical processes in these media.

New technical developments concerning the implementation of smart sensors and data transfer enhance the functionality of the measurement system. The applied ISM frequency band of 433 MHz in many cases does not provide the required speed for data transfer, which is limited to 9600 kbit/sec. However at the design stage the electronic components for wireless data transmission assuring the assumed criteria existed only for this frequency band. Being aware of new telecommunication developments this part of the system can be the most easily modified to fulfil the lowest power consumption and highest speed data transfer. The measurement system will be enhanced by other existing and popular sensors that are applied in soil physics and chemistry as

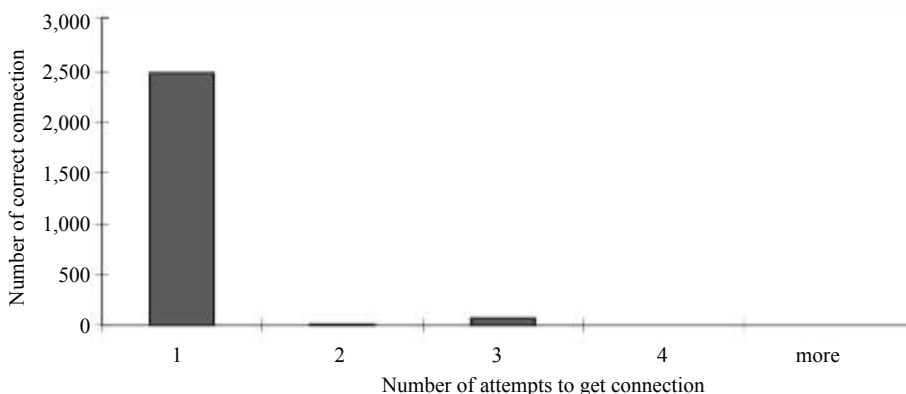

Fig. 5. A histogram presenting the frequency of successful data transfer between MASTER and SLAVE devices

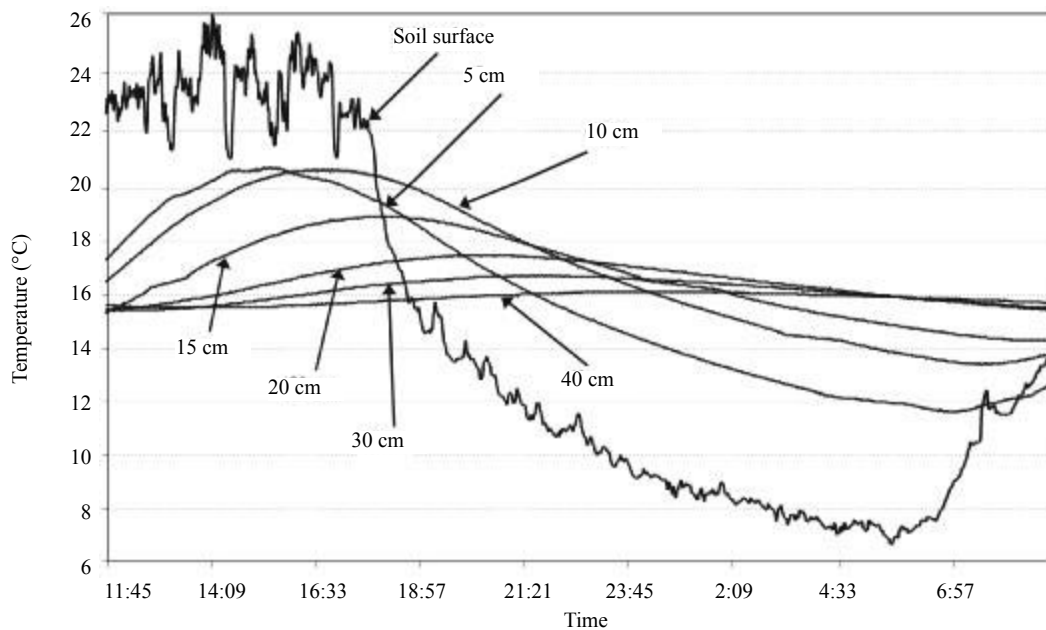

Fig. 6. Example readout of temperature sensors located on different depths of soil profile

well as environmental protection (psychrometric sensors, porous blocks, wind gauges, solar gauges, redox potential, oxygen diffusion rate sensors and pH sensors, ion selective electrodes, etc.). These sensors with additional electronics as an element of control and computation are intended to form Plug-and-Play smart sensors working according to IEEE 1451 standard.

### CONCLUSIONS

The presented monitoring system for the measurement of soil physical parameters is intended to be equipped with smart sensors and wireless communication in the ISM (Industrial, Scientific, Medical) frequency band 433 MHz.

Partial implementation of the system in the form of two-point communication for the temperature measurement in a soil profile proves that the availability of advanced technology enables to enhance the existing measurement systems and sometimes only the sensors with functional and not expensive radio communication the distance of several hundred metres.

The developed hardware and software can be adapted to more complex monitoring systems working in compliance with IEEE 1451 standard and covering larger areas including air-borne or satellite remote sensing and serve as a source for ground reference measurements.

### List of symbols and abbreviations

IAPAS	Institute of Agrophysics of Polish Academy of Sciences in Lublin, Poland
IEEE 1451	Set of smart sensor network standard under development by the Institute of Electric and Electronic Engineers

ISM band	Industrial, Scientific and Medical licence free frequency band
MEMS	Micro-Electro-Mechanical System
MMC	Multi-Media memory card
NCAP	Network-Capable Application Processor
NIST	National Institute of Standards and Technology
ODR	Oxygen Diffusion Rate
SD	Security Digital memory card
STIM	Smart Transducer Interface Module
TBIM	Transducer Bus Interface Module
TDR	Time Domain Reflectometry
TEDS	Transducer Electronic Data Sheet
TII	Transducer Independent Interface

### References

- FIGLIOLA R.S., 1999. Operational Modes of Instrumentation. In: WEBSTER J.G., The Measurement Instrumentation and Sensors Handbook. CRC Press/IEEE Press, Boca Raton, FL, Chapter 2: 1–8.
- LEE K.B., 2003. The smart transducer interface standard (IEEE P1451). NIST Workshop on Data Exchange Standards at the Construction Site. NIST, Gaithersburg.
- MALICKI M.A., PLAGGER R., ROTH C.H., 1996. Reduction of soil matrix effect on TDR dielectric moisture determination by accounting for bulk density or porosity. *Eur. J. Soil Sci.*, 47: 357–366.
- MALICKI M.A., SKIERUCHA W.M., 1989. A manually controlled TDR soil moisture meter operating with 300 ps rise-time needle pulse. *Irrigation Sci.*, 10: 153–163.
- MALICKI M.A., WALCZAK R.T., 1999. Evaluating soil salinity status from bulk electrical conductivity and permittivity. *Eur. J. Soil Sci.*, 50: 505–514.
- SKIERUCHA W., MALICKI M.A., 2002. Dielectric mixing models: validation in mineral soils. Poster Presentation.

- 17<sup>th</sup> World Congress of Soil Science, Bangkok, Abstracts Vol. 1: 147.
- TOPP G.C., DAVIS J.L., ANNAN A.P., 1980. Electromagnetic determination of soil water content: measurements in coaxial transmission lines. *Wat. Res. Res.*, 16: 574–582.
- WALCZAK R., 1987. Basic problems of mass and energy transfer in the soil-plant-atmosphere system. *Zeszyty Probl. Post. Nauk Roln.*, 346: 12–22.
- WICZER J., 2001. Connectivity: smart sensors or smart interfaces. ISA 2001 Emerging Technologies Conference, Huston, Sept.: 10–13. [http://sensorsynergy.com/Smart\\_Connectivity.pdf](http://sensorsynergy.com/Smart_Connectivity.pdf).
- WILCZEK A., MAZUREK W., SKIERUCHA M., 2003. Application of wireless communication in automatic monitoring of temperature in soil profile. *Acta Agrophys.*, 93: 123–133.

Received for publication July 2, 2004  
Accepted after corrections August 13, 2004

## Použití inteligentních senzorů při měření fyzikálních parametrů půdy

**ABSTRAKT:** Studie předkládá projekt a dílčí implementaci moderního monitorovacího systému pro měření fyzikálních parametrů půdy. Systém využívá inteligentní senzory vybavené schopností elektronické konverze signálu, individuální identifikací a sdělovacími prostředky, omezujícími složitost měřicího systému, a také výskyt chyb měření, které se mohou vyskytovat při přenosu analogového signálu po kabelech spojujících senzory s měřicí jednotkou. Použitý systém bezdrátové komunikace pracuje v bezlicenčním pásmu ISM (určeném pro průmysl, vědu a medicínu) o frekvenci 433 MHz a přenáší příkazy a data mezi vzdáleným počítačem kompatibilním s PC (jako řídicí jednotkou) a inteligentními senzory (jako podřízenými jednotkami) na vzdálenost několika set metrů. Uvedená dílčí implementace systému měří teplotu v několika místech půdního profilu v polních podmínkách a komunikuje s hostitelským počítačem bezdrátovým přenosem. Vyvinutý hardware a software jsou koncipovány tak, aby mohly být upraveny i pro složitější monitorovací systémy, pracující v souladu s normou IEEE 1451 pro inteligentní převodníková rozhraní, pokrývající velké plochy jako prvek vzdáleného leteckého nebo družicového snímání, a sloužící pro pozemní referenční měření. Bylo dokázáno, že v současné době dostupné technické prostředky umožňují použít inteligentní senzory a bezdrátové spojení při monitorování životního prostředí za ekonomicky přijatelných podmínek. Malé zvýšení ceny systému měření pomocí inteligentních senzorů, vybavených některými prvky řídicí a výpočetní techniky a rádiové komunikace, zajišťuje omezení chyb měření a umožní operátorovi systému snadný sběr dat o životním prostředí.

**Klíčová slova:** inteligentní senzory; monitorování; modelování; radiokomunikace; agrofyzika

---

*Corresponding author:*

Dr. WOJCIECH SKIERUCHA, Instytut Agrofizyki PAN, ul. Doswiadczalna 4, P.O. Box 21, 20-290 Lublin 27, Polska  
tel.: + 48 744 50 61, fax: + 48 744 50 67, e-mail: [w.skierucha@demeter.ipan.lublin.pl](mailto:w.skierucha@demeter.ipan.lublin.pl)

---