

## Use of waste material mixtures for energy purposes in small combustion devices

J. MALAŤÁK<sup>1</sup>, J. BRADNA<sup>2</sup>

<sup>1</sup>*Department of Technological Equipment of Buildings, Faculty of Engineering,  
Czech University of Life Sciences Prague, Prague, Czech Republic*

<sup>2</sup>*Research Institute of Agricultural Engineering, Prague, Czech Republic*

### Abstract

MALAŤÁK J., BRADNA J., 2014. **Use of waste material mixtures for energy purposes in small combustion devices.** Res. Agr. Eng., 60: 50–59.

The article assesses the energy use of solid biofuels (wheat and rape straw) and their blends with suitable additives (cocoa husks, brown coal and coal sludge). The elemental and stoichiometric analysis evaluates their suitability for energy recovery. Furthermore, thermal emission characteristics in automatic hot water boiler VERNER A251 are observed. The results of thermal emission measurements show that all samples meet the requirements of the Directive No. 13/2006 for carbon monoxide (2,000 mg/m<sup>3</sup>). The average nitrogen oxides emission concentrations exceed emission limits compared with the Directive No. 13/2006 (250 mg/m<sup>3</sup>) for all samples of solid biofuels. One reason is the high temperature in the combustion chamber that increases combustion temperature and results in high temperature of nitrogen oxides. Another problem is carbon monoxide that depends on the coefficient of excess air. The value of this coefficient drops under its optimum (2.5) and subsequently follows an increasing trend.

**Keywords:** biomass; additives; cocoa husks; brown coal; coal sludge; net calorific value; emission

To summarize the current situation, the development in relation to the environment, waste management, energy and agriculture issues in individual EU countries leads to a number of outstanding issues such as the continued release of CO<sub>2</sub> into the atmosphere, emissions growth, increasing dependence on fossil fuels, searching for new resources to meet the households energy needs, etc. Not only from an energy point of view but also in terms of maintaining the environment quality, demands on quality of solid biofuels increase. High quality pellets from waste biomass and other appropriate materials (e.g. waste or industrial sector) are required primarily for combustion in small combus-

tion plants. Fuel quality is not so critical for larger combustion devices that are equipped with flue gas cleaning and combustion process control. For this reason, it is appropriate to differentiate between two types of solid biofuels in the form of pellets, namely for industrial or small domestic combustion devices (OBERNBERGER, THEKA 2004).

Research into energy use methods of solid biofuels and their mixtures with suitable additives is an integral part of the practical work. As representatives from the agricultural sector wheat and rape straw waste biomass are used; as additives cocoa husks are selected, and from energetic sector it is brown coal and coal sludge. Clarification of combustion

processes, thermal parameters and stoichiometry of solid fuels in their energy use will serve us to assess the suitability of these biofuels combustion in a combustion device with respect to the environment.

The aim is to verify the possibility of solid biofuels energy use in the form of pressed pellets of selected waste materials from agricultural production and their mixtures with suitable additives from the industrial and waste sector. It is necessary to rely on the chemical composition of used fuel, ash, stoichiometric calculations and operational parameters of the combustion device type when assessing, optimizing and selecting appropriate types of raw materials for biofuel production. The aim is to determine the thermal-emission properties and minimize emission indicators of combustion device for energy use of selected solid alternative biofuels samples in accordance with applicable legislation and standards.

## MATERIAL AND METHODS

The experimental part is based on targeted research and selection of raw materials for the solid alternative fuels production. Samples of pellets made from waste biomass (wheat and rape straw) were supplemented by pellets made from mixed samples of waste biomass and selected additives. Such selected samples were within the optimization process of production mixed with selected waste products in specialized company Atea Praha, Ltd. Their improving thermal emission properties for the resulting solid biofuel were taken into account when selecting and mixing waste materials.

Cocoa husks, brown coal and coal sludge were selected as additives. Selected ratios of blending additives in cocoa husks 5%, brown coal 8% and coal sludge 6% were determined according to scientific studies. In addition to elemental and stoichiometric analysis experimental thermal emission measurements were done for pure wheat and rape straw, and their four mixtures with listed additives.

Selected raw material types for solid alternative biofuel production and their mixtures in the form of pellets with a diameter 8 mm:

- wheat straw,
- rape straw,
- wheat straw and cocoa husks (5%),
- rape straw and cocoa husks (5%),
- wheat straw and brown coal (8%),
- wheat straw and coal sludge (6%).

The experimental part of the work was finished by selected samples combustion in automatic hot water boiler VERNER A251 (Verner a.s., Červený Kostelec, Czech Republic), the process was monitored by sensor of analyser GA-60 (Madur Electronics, Vienna, Austria) in the chimney and the measured values were the basis for the energy use assessment in the above mentioned fuel combustion device.

Methodology of the work was divided into several sub-methodologies:

- methodology for determining elemental composition of biofuels samples;
- methodology for determining gross and net calorific values of solid biofuels samples;
- methodology for determining stoichiometry of combustion processes;
- methodology for measuring emission concentrations;
- methodology of converting pollutant concentrations;
- methodology of statistical analysis.

Determination of the fuel elemental composition has a major impact on all stoichiometric calculations, thermal emission properties calculations of fuels and combustion devices in the research work. For determination of evaluated solid biofuels samples elemental composition basic (elemental) analysis was used, which determined the percentage by weight of carbon, hydrogen, oxygen, sulphur, nitrogen and any water in main fuel. All elemental analyses of the samples in this study were for normal conditions (temperature  $T = 0^{\circ}\text{C}$  and pressure  $p = 101.325\text{ kPa}$ ). Elemental analyses were made by the Institute of Chemical Technology Prague, Faculty of Environmental Technology. Carbon, hydrogen and nitrogen were determined on analyser CHN Perkin-Elmer 2400 (PerkinElmer, Waltham, USA). For determination of chlorine and sulphur samples were burned in the oxy-hydrogen flame at Wickbold apparatus (Koehler Instrument Comp., New York, USA). Incombustible fuels substances, i.e. ash and all the water content, were determined by combustion and drying the sample, respectively. To determine the total water content certified moisture analyser Ohaus MB 25 (Ohaus Corp., Parsippany, USA) was used. Measurements were carried out according to ČSN EN 14774-3 (2010).

For selected biofuel samples granulation pelletizing line with one granulator LSP1800 (Atea Praha, Chrástany, Czech Republic) (1,000 kg/h) was used. The basic raw material was pressed straw (wheat, rape) in square bales with maximum cross-section of  $120 \times 120\text{ cm}$  with moisture content 11.3%. Line 1800

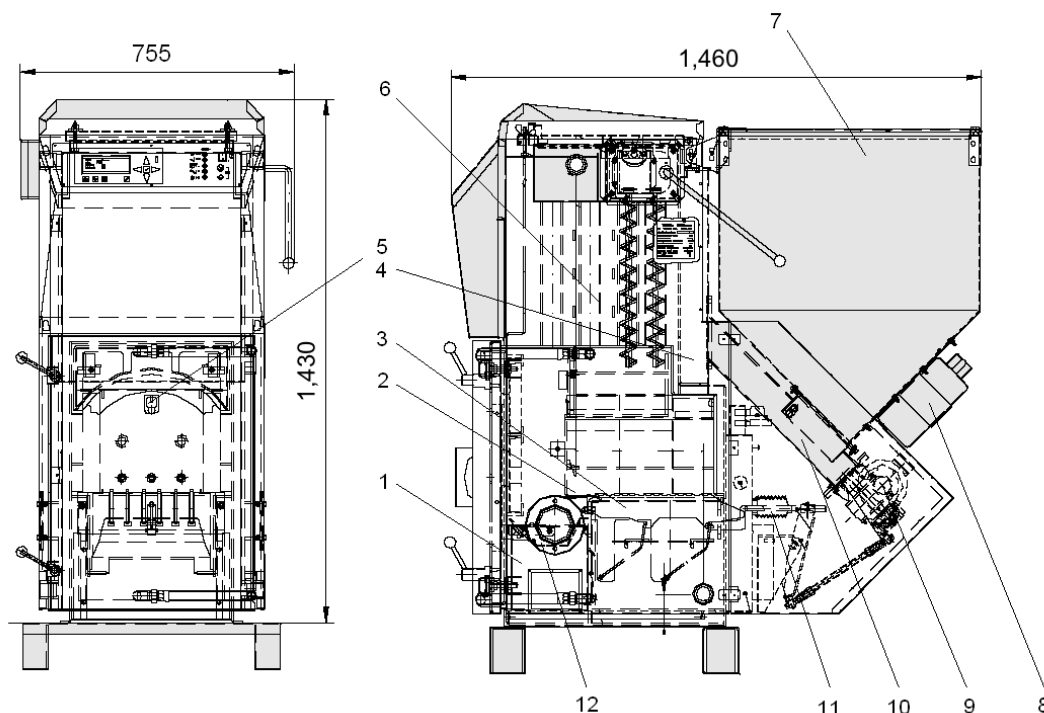

Fig. 1. Diagram of the combustion device – VERNER A251

1 – ashes pan; 2 – burner chamber; 3 – grate bar; 4 – fuel fallout; 5 – fuel diffuser; 6 – vortex-generators; 7 – hopper; 8 – fire extinguishing equipment; 9 – transmission with an electric motor; 10 – screw conveyor; 11 – grate bar drive; 12 – ashes trough

LSP processed straw and its mixtures with selected additives to pellets form with diameter of 8 mm. Pellets made by this device correspond to ČSN 14961 (2010). The line is designed for production of fuel pellets from rape and wheat straw with a diameter of 6 or 8 mm, length – 40 mm, crumble to 2%, power consumption 110–130 kWh (87 W/kg pellets).

Gross calorific value of examined biofuel samples was determined by measuring in the calorimeter IKA 2000 (IKA®-Werke GmbH & Co. KG, Staufen, Germany) by ČSN EN 14 918 (2010). Net calorific value was determined by calculation where the results of individual biofuel samples elemental analyses were used.

All analysed fuel samples were considered by stoichiometric calculations that complement fuel samples characteristics in the work and are the basis for emission characteristics calculations. Determined parameters are especially important for solving many design practice problems, as well as for operation control of existing combustion devices. The calorific value of biofuel, the amount of oxygen (air) required for the complete combustion of biofuel, the flue gas quantity, composition and density are determined in these calculations.

For proper verification of examined solid fuels samples automatic hot water boiler VERNER A251 (Fig. 1) designed for different types of renewable fuels combustion (wood, pellet plant, grain, etc.) was used. It is used as a convenient, economical and environmentally friendly heat source for heating, water heating and similar applications. Thermal-technical specifications of combustion device – VERNER A251 are shown in a table presented on company web pages ([www.verner.cz](http://www.verner.cz)).

The setting of emission concentrations of individual flue gas components is an important task. The measurements must be carried out in accordance with ČSN 12 4070 (1990), ČSN 38 5509 (1991), ČSN 07 0240 (1993) and ČSN 44 1310 (2001). The device GA-60 (Madur Electronics, Vienna, Austria) was used for the determination of emission concentrations of individual flue gas components developed during the combustion of biofuel samples mixtures with selected additives. This is a multi-purpose analyser of flue gas. Its principle is based on the use of electrochemical converters. The standard equipment includes the converters for analysis of following flue gas components: oxygen (O<sub>2</sub>), carbon monoxide (CO), nitric oxide (NO), nitrogen dioxide

Table 1. Resulting regression equation with the value of reliability

	Regression equation	$R^2$
<b>Wheat straw and cocoa husks (5%)</b>		
Carbon dioxide $\text{CO}_2$ depending on the excess air coefficient $n$ (%)	$\text{CO}_2 = 19.166n^{-1.0116}$	
Carbon monoxide $\text{CO}$ depending on the excess air coefficient $n$ ( $\text{mg}/\text{m}^3$ )	$\text{CO} = 68.488n^2 - 334.63n + 526.38$	0.45
Flue gas temperature $T_{\text{sp}}$ depending on the excess air coefficient $n$ ( $^{\circ}\text{C}$ )	$T_{\text{sp}} = 305.12n^{0.5805}$	0.54
Nitrogen oxides $\text{NO}_x$ depending on the excess air coefficient $n$ ( $\text{mg}/\text{m}^3$ )	$\text{NO}_x = 308.12n^{0.1494}$	0.67
<b>Rape straw and cocoa husks (5%)</b>		
Carbon dioxide $\text{CO}_2$ depending on the excess air coefficient $n$ (%)	$\text{CO}_2 = 19.056n^{-1.0068}$	
Carbon monoxide $\text{CO}$ depending on the excess air coefficient $n$ ( $\text{mg}/\text{m}^3$ )	$\text{CO} = 79.648n^2 - 254.55n + 226.62$	0.81
Flue gas temperature $T_{\text{sp}}$ depending on the excess air coefficient $n$ ( $^{\circ}\text{C}$ )	$T_{\text{sp}} = 1.2956n^2 - 26.566n + 329.78$	0.77
Nitrogen oxides $\text{NO}_x$ depending on the excess air coefficient $n$ ( $\text{mg}/\text{m}^3$ )	$\text{NO}_x = -6.6453n^2 + 92.265n + 352.63$	0.14
<b>Wheat straw and brown coal (8%)</b>		
Carbon dioxide $\text{CO}_2$ depending on the excess air coefficient $n$ (%)	$\text{CO}_2 = 19.103n^{-1.0087}$	
Carbon monoxide $\text{CO}$ depending on the excess air coefficient $n$ ( $\text{mg}/\text{m}^3$ )	$\text{CO} = 25.177n^2 - 117.74n + 257.14$	0.81
Flue gas temperature $T_{\text{sp}}$ depending on the excess air coefficient $n$ ( $^{\circ}\text{C}$ )	$T_{\text{sp}} = -0.8236n^2 - 1.3254n + 293.82$	0.63
Nitrogen oxides $\text{NO}_x$ depending on the excess air coefficient $n$ ( $\text{mg}/\text{m}^3$ )	$\text{NO}_x = -10.288n^2 + 151.1n + 412.37$	0.45
<b>Wheat straw and coal sludge (6%)</b>		
Carbon dioxide $\text{CO}_2$ depending on the excess air coefficient $n$ (%)	$\text{CO}_2 = 19.165n^{-1.0114}$	
Carbon monoxide $\text{CO}$ depending on the excess air coefficient $n$ ( $\text{mg}/\text{m}^3$ )	$\text{CO} = 55.718n^2 - 321.44n + 581.89$	0.48
Flue gas temperature $T_{\text{sp}}$ depending on the excess air coefficient $n$ ( $^{\circ}\text{C}$ )	$T_{\text{sp}} = -7.8105n^2 + 30.168n + 248.35$	0.62
Nitrogen oxides $\text{NO}_x$ depending on the excess air coefficient $n$ ( $\text{mg}/\text{m}^3$ )	$\text{NO}_x = 76.07n^{2.0352}$	0.57

( $\text{NO}_2$ ), sulphur dioxide ( $\text{SO}_2$ ) and hydrogen chloride ( $\text{HCl}$ ). Technical data of this analyser are shown in a table on company web pages ([www.madur.com](http://www.madur.com)).

Statistical analysis of relationships between variables – regression analysis was used for the measurement evaluation. This analysis allowed solving the main tasks: to find a form of dependence, express it by mathematical function and determine the degree of approximation value of dependent variable of predicted regression functions to the real values of this variable observed in the selected sample. Regression equations for mixed solid biofuel samples are listed in Table 1 with the value reliability.

## RESULTS AND DISCUSSION

The elemental analysis resulting values of selected solid biofuel samples in the original state are shown in Table 2. The resulting parameters were compared and evaluated in accordance with Direc-

tive No. 55-2008 of the Ministry of the Environment of the Czech Republic (MŽP ČR).

According to the specific requirements for pellets according to Directive No. 55-2008 MŽP ČR the max. permissible amount of nitrogen is 0.90%. Wheat and rape straw samples, rape straw mixed with cocoa husk and wheat straw with brown coal comply with this directive.

Another reference element in the fuel is chlorine. Chlorine passes during combustion in large part to the gaseous phase. According to the specific requirements for pellets under Directive No. 55-2008 MŽP ČR the max. acceptable amount of chlorine is 0.18%. Specific requirements for chlorine are fulfilled for all fuel samples. Higher chlorine concentrations in examined samples in the original state where the value exceeded 0.1% of the fuel proportion were in rape straw, wheat and rape straw with cocoa husks, wheat straw with brown coal and coal sludge.

For thermal devices using solid fuels from renewable resources there is usually no problem in terms

Table 2. Resulting values of selected solid biofuel samples in its original condition

Sample	Water (% wt.)	Ashes (% wt.)	Combustible matter volatile (% wt.)	Combustible matter non-volatile (% wt.)	Gross calorific value (MJ/kg)	Net calorific value (MJ/kg)	Carbon (% wt.)	Hydrogen (% wt.)	Nitrogen (% wt.)	Sulphur (% wt.)	Oxygen (% wt.)	Chlorine (% wt.)
Wheat straw	6.40	6.33	69.81	17.46	16.93	15.45	43.04	6.51	0.72	0.05	36.89	0.09
Rape straw	7.85	5.64	70.11	16.40	16.75	15.23	43.64	6.11	0.84	0.14	35.64	0.14
Wheat straw and cocoa husks (5%)	5.05	8.89	69.22	16.84	16.70	15.27	42.91	6.35	1.15	0.05	35.44	0.12
Rape straw and cocoa husks (5%)	5.71	7.18	70.55	16.56	17.22	15.78	42.56	6.37	0.89	0.10	37.02	0.17
Wheat straw and brown coal (8%)	7.48	6.84	67.35	18.33	17.20	15.71	44.16	6.38	0.73	0.09	34.22	0.12
Wheat straw and coal sludge (6%)	6.51	7.02	66.90	19.57	16.48	15.18	43.80	6.10	1.01	0.11	34.12	0.13

of sulphur emission limits, as evidenced by selected samples according to Table 1. By the specific requirements for pellets according to Directive No. 55-2008 MŽP ČR the max. permissible amount of sulphur is 0.15%. The decisive factor in the concentration of sulphur in fuel can be corrosive behaviour. Other values of elemental analysis meet the optimal parameters for the use of selected biofuel samples for combustion devices.

For thermal fuel use the water and ash content is crucial. The scope of any water contained in the samples was quite low, which had a positive contribution to heating value of each biofuel samples. Ash content in the samples was different, as you can see from elemental analyses of selected samples in Table 1. By the specific requirements for pellets according to Directive No. 55-2008 MŽP ČR the max. amount of ash calculated in anhydrous

condition is 6%. This condition was fulfilled only in rape straw pellets. The amount of any water and ash significantly affects the thermal properties of samples under consideration and consequently affects both selection and adjustment of the combustion device. Primarily increased amount of ash affects the burner combustion devices operation, as confirmed by research paper of authors OLSSON and KJÄLLSTRAND (2006) and GÜRDİL et al. (2009).

Calorific value of each sample is summarized in Table 1. The specific requirements for pellets according to Directive No. 55-2008 MŽP ČR set min. relative calorific value on anhydrous condition as 16 MJ/kg. This condition was fulfilled by all assessed fuels.

The resulting values of the stoichiometric analysis point to a very good thermal emission parameters of examined samples. Basic stoichiometric analysis resulting values of biofuel samples in origi-

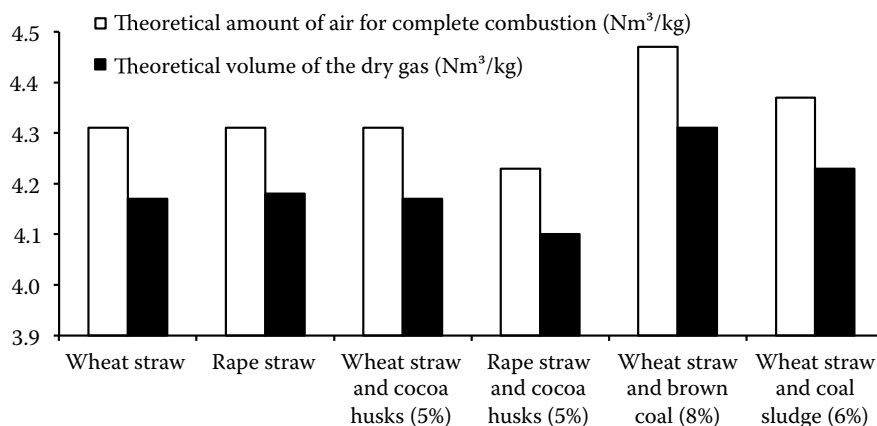

Fig. 2. Resulting values of air and dry flue gas theoretical volume amount

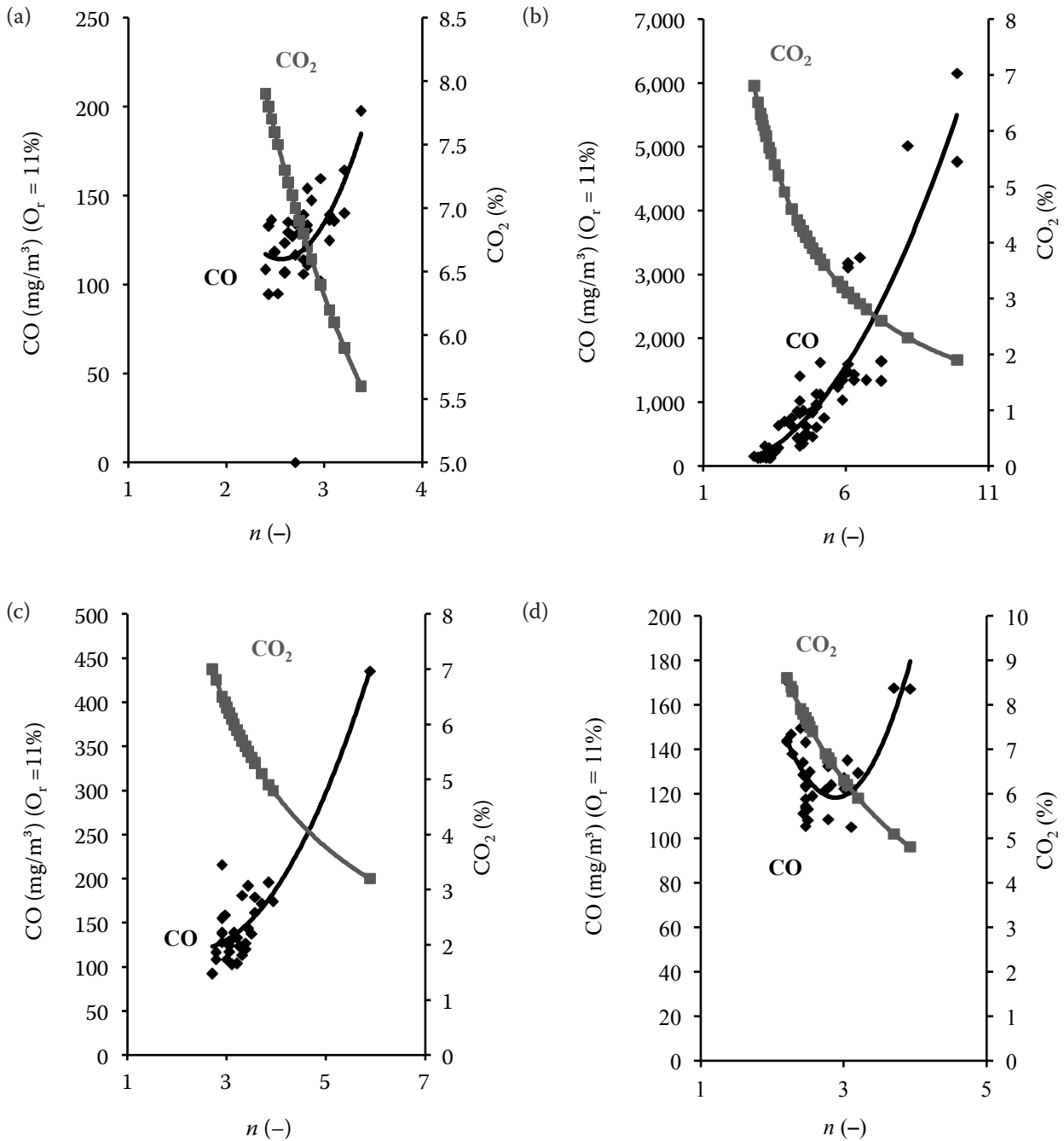

Fig. 3. Measured emission concentrations of CO and CO<sub>2</sub> depending on the excess air coefficient ( $n$ ) – calculated from the concentration of CO<sub>2</sub> in dry flue gas at reference oxygen content in flue gas 11% under normal conditions for biofuel samples: (a) wheat straw and cocoa husks (5%), (b) rape straw and cocoa husks (5%), (c) wheat straw and brown coal (8%) and (d) wheat straw and coal sludge (6%)

O<sub>r</sub> – reference content of oxygen in the flue gas

nal condition are shown in Fig. 2. All volumes and weights of the combustion air and flue gas are given under so-called normal conditions, i.e. at  $T = 0^{\circ}\text{C}$  and pressure  $p = 101.325\text{ kPa}$  and to the reference content of oxygen in the flue gas  $O_r = 11\%$ .

Graphical dependence of carbon monoxide and carbon dioxide on the coefficient of excess air is set for individual samples of solid biofuels to assess the combustion process. Graphical presentation of the course of carbon monoxide and carbon dioxide de-

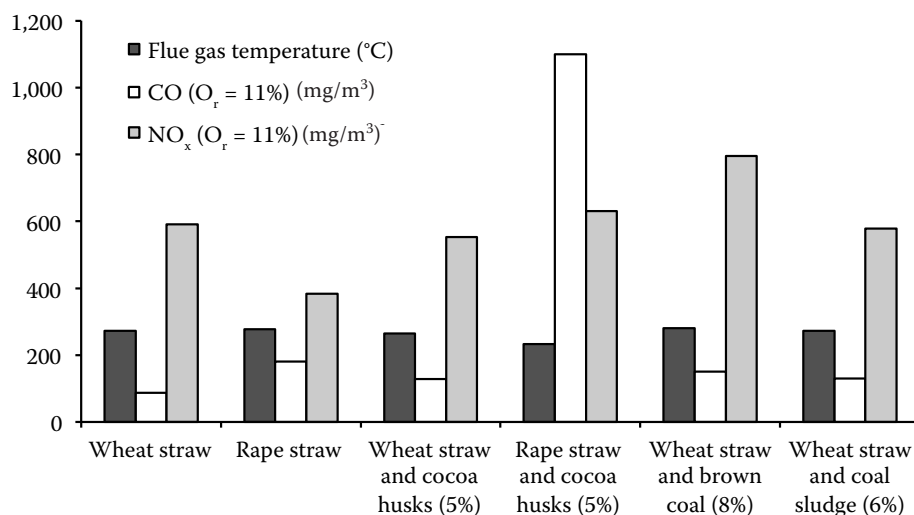

Fig. 4. Average thermal emission properties of solid fuel samples

$O_r$  – reference content of oxygen in the flue gas

pending on the excess air coefficient is significant due to process and its interaction with combustion environment, see Fig. 3.

Optimal boundary of combustion air intake into the combustion chamber is about twice the excess air coefficient. The air content was selected at the value of 2.1 times for the previous calculations according to Annex 7 to the Government Regulation No. 146/2007 Coll. and Directive No. 13-2006, where the reference oxygen content in the flue gas is equal to 11%.

The resulting average emission concentrations of carbon monoxide in the combustion device achieved in all analysed solid biofuel samples of low emission concentrations on average 267 mg/m<sup>3</sup>. Sample of rape straw mixed with cocoa husks at 1,099 mg/m<sup>3</sup> reached higher average carbon monoxide emission concentration. All samples met the requirements of Directive No. 13-2006, where the carbon monoxide emission limit is 2,000 mg/m<sup>3</sup>. The resulting average emission concentrations of carbon monoxide for individual fuel samples for combustion device are shown in Fig. 4.

The average nitrogen oxides emission concentrations are compared to emission standards Directive No. 13-2006 (250 mg/m<sup>3</sup>); it was exceeded in all samples of solid biofuels. There can be more causes for such high emissions of nitrogen oxides. In particular, increased fuel nitrogen in the sample itself passes into the gaseous phase. Another option is a large amount of combustion air that is fed into the combustion chamber; this fact is also demonstrated by the results of measuring of increased formation of nitrogen oxides. Last rise to the formation of these emissions is high combustion temperature,

which is characterized by temperature of outgoing exhaust gases during the measurement, see Fig. 3.

Flue gas temperature for single fuel sample in combustion device varies in a wide range. Flue gas temperature reached high values during all measurements in combustion device. Flue gas temperature difference for individual samples can be justified by the amount of air supplied to the combustion device, calorific value of samples and weight portion of volatile components in the sample. Thus provided high temperature flue gas increases heat loss by noticeable heat of exhaust gas.

In all examined samples of solid biofuels dependence of carbon dioxide, a product of complete combustion, and excess air coefficient is determined, which is similar in all cases (Fig. 3). With increasing coefficient of excess air (air volume) it leads to a decrease in the concentration of carbon dioxide from the maximum to the minimum concentration. The decrease in the concentration of carbon dioxide is mainly due to flame cooling and dilution of exhaust gas by combustion air. The resulting graphical dependence is provided for each kind of mixture solid biofuel sample (Fig. 4). Dependence is described by regression equations in Table 2.

Another important component of the exhaust gas is carbon monoxide, a product of incomplete combustion. Carbon monoxide depends on the coefficient of excess air, in very low coefficient of excess air it soon decreases until the optimal values of the excess air coefficient (about 2.5). There is a gradual increase in carbon monoxide up to its max. concentration after crossing the optimal values of the excess air coefficient. The gradual increase of carbon monoxide occurred from the beginning of

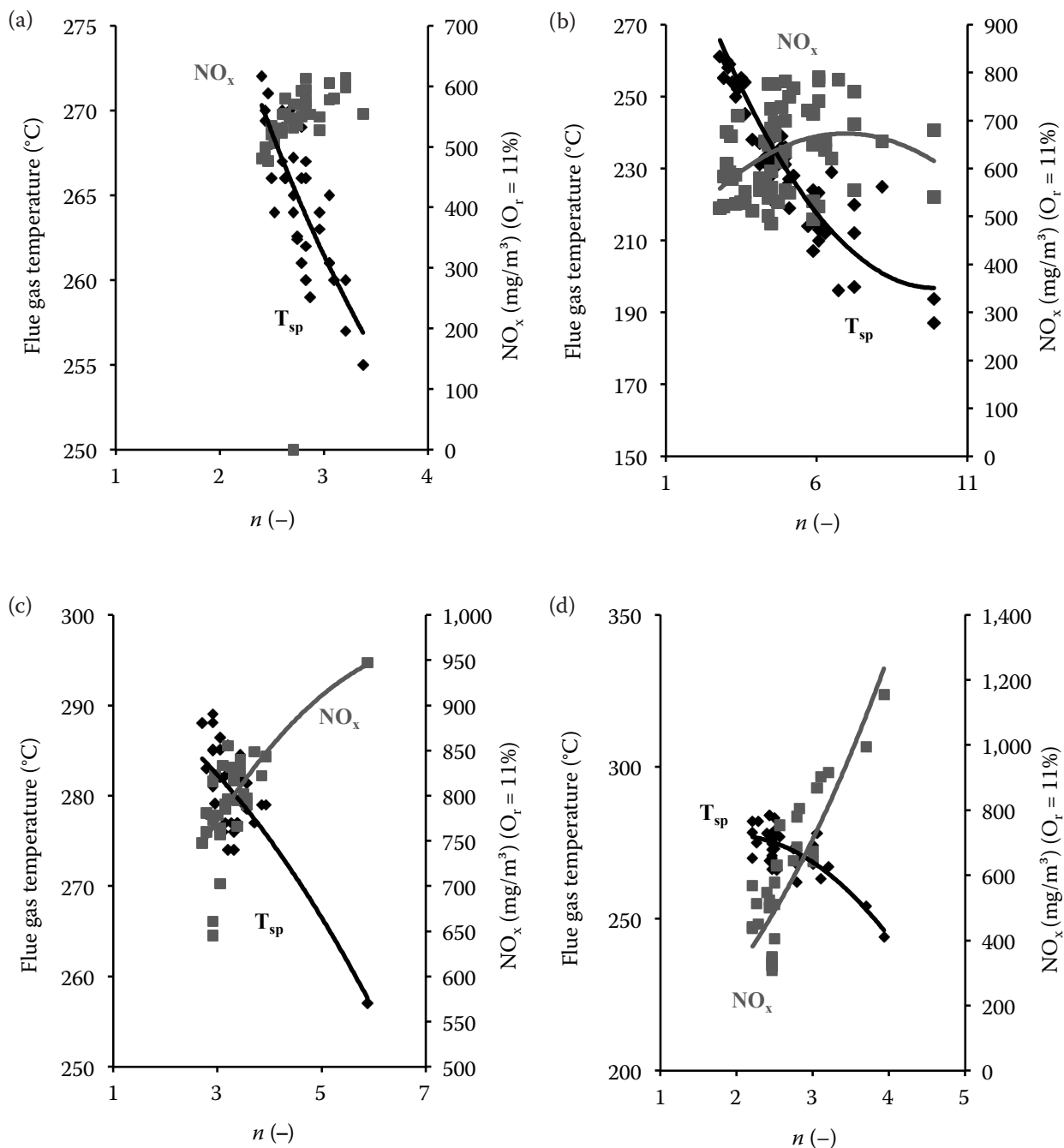

Fig. 5. Course of temperature and flue gas emission concentrations of  $\text{NO}_x$  depending on the excess air coefficient ( $n$  is calculated from the concentration of  $\text{CO}_2$ ) in dry flue gas at reference oxygen content in flue gas 11% under normal conditions for biofuel samples: (a) wheat straw and cocoa husks (5%), (b) rape straw and cocoa husks (5%), (c) wheat straw and brown coal (8%) and (d) wheat straw and coal sludge (6%)

$O_r$  – reference content of oxygen in the flue gas

measurements on samples of mixed biofuel from wheat straw and cocoa husks, rape straw and cocoa husks and wheat straw with brown coal.

The reason why the combustion process occurs in another way in these samples of mixed biofuels

can be found in a variety of factors, such as calorific value, the percentage of volatile matter in the sample and the amount of combustion air supplied to the combustion chamber. Also the combustion device itself may lead to insufficient mixing of volatile flam-



mable substances with combustion air and insufficient burn process (MALAŤÁK, PASSIAN 2011). The resulting progressions are described by regression equations with given confidence level and are listed in Table 2. The confidence level is between moderate to strong dependence on the excess air coefficient.

Fig. 5 shows the resulting progressions of exhaust gas temperature and emission concentrations of nitrogen oxides depending on the excess air coefficient in dry flue gas at reference oxygen content in flue gas 11% under normal conditions. Curves expressed in this way illustrate the relationship between nitrogen oxides emissions, temperature and excess air coefficient (combustion air). In the course of increasing excess air coefficient it leads to cooling the flame and thereby the flue gases. This temperature progress can be observed in all cases.

Emission concentrations of nitrogen oxides depending on the excess air coefficient have an increasing concentration in the flue gas in contrast to exhaust gas temperatures. The amount of nitrogen oxides emission concentrations is higher with the help of high temperature of exhaust gas. Exceptions are samples of pellets produced from rape straw and cocoa husks, which decrease the emission concentration of nitrogen oxides with increasing excess air coefficient. The reason why such decrease in the emission concentration of nitrogen oxides occurs is in the flue gas temperature. The flue gas temperature during combustion of rape straw and cocoa husks dropped below 200°C while increasing the excess air coefficient; it also occurred in a decline in emissions concentrations of nitrogen oxides.

The resulting progressions are described by regression equations with the given confidence level and are listed in Table 2. The confidence level is between moderate to strong dependence on the excess air coefficient except for the rape straw pellets with cocoa husks, where the emissions of nitrogen oxides depending on the excess air coefficient have a weak dependence between them.

## CONCLUSION

The results of thermal emission measurements show that all samples meet the requirements of Directive No. 13-2006 for carbon monoxide, but the average nitrogen oxides emission concentrations exceed emission limits. One reason is the high temperature in the combustion chamber, which increases the temperature of combustion, and this

gives rise to a high temperature of nitrogen oxides. The optimal value of the excess air coefficient for low carbon monoxide concentrations is around 2.5, but this value is unable to accomplish in common small combustion devices. Emissions of nitrogen oxides concentrations grew during the measurement with the help of high temperature flue gases and increasing of the excess air coefficient. Exception was a sample from rape straw pellets and cocoa husks, which decreased the emission of nitrogen oxides concentrations with excess air coefficient increasing and flue gas temperature decreasing.

The solid biofuels advantage is that they contain trace amounts of sulphur so there is no harmful gas fumes of SO<sub>2</sub> during combustion, as it is clear from the analyses carried out in this paper. The temperature of the flue gas dew point reduces as a result, because its value is only a function of water vapour content in flue gas and excess air (NORDIN 1994).

Another problematic component in solid biofuels is chlorine; its concentration in biofuel from wheat straw reached large values. One of the ways how to reduce these large concentrations of chlorine is washing (leaching) in water to prevent the action of chlorine in the combustion device. As recommended by KHOR et al. (2007), fertilizers rich in chlorine release when washing.

Largest emission concentration of CO is achieved at a high excess air coefficient. The high amount of combustion air also cools combustion chamber and results in high emissions of carbon monoxide in flue gas (JOHANSSON et al. 2004). Combustion device should work in nominal parameters, as demonstrated by studies, any uncontrolled flow change of combustion air and material leads to high emissions of carbon monoxide (WIHERSAARI 2005; FIEDLER, PERSSON 2009).

The content of carbon dioxide (CO<sub>2</sub>) can be an indicator of combustion quality (effectiveness). If at low excess air (complete combustion) the highest possible concentrations of CO<sub>2</sub> are achieved, the losses caused by flue gas are minimal (flue gas at the same temperature). There is a max. available proportion of carbon dioxide in flue gas (the CO<sub>2max</sub>) for each fuel, which is given by the elemental composition of combustible fuel. This value, however, is unattainable in common combustion devices (OLSSON, KJÄLLSTRAND 2006).

In the ESKILSSON (2004) research work a compromise between unburned carbon oxides and nitrogen oxides is presented. Decreasing amount of air in the combustion chamber reduces the amount of nitrogen

oxides in flue gases, but on the other hand increases emissions of unburned carbon oxides. Finding the optimal excess air coefficient settings for different types of biofuels solves the problem with nitrogen oxides and carbon monoxide emissions. In the areas of optimal excess air coefficient concentrations of nitrogen oxide are low with the exception of crops with high nitrogen content in fuel (STREHLER 2000). The combustion process control has to be carried out in these cases, as recommended in other research works.

### References

- ČSN 07 0240, 1993. Teplovodní a nízkotlaké parní kotle. Základní ustanovení. [Warm water and low-pressure steam boilers. Basic regulations.] Prague, Czech Office for Standards, Metrology and Testing.
- ČSN 12 4070, 1990. Zařízení odlučovací. Metody měření veličin. [Dust collecting equipment. Measuring methods of quantity features.] Prague, Czech Office for Standards, Metrology and Testing.
- ČSN 14961, 2010. Tuhá biopaliva – Specifikace a třídy paliv. [Solid Solid biofuels – Fuel specifications and classes.] Prague, Czech Office for Standards, Metrology and Testing.
- ČSN 38 5509, 1991. Plynná paliva. Fyzikální konstanty. [Gaseous fuels. Physical constants.] Prague, Czech Office for Standards, Metrology and Testing.
- ČSN 44 1310, 2001. Tuhá paliva – Označování analytických ukazatelů a vzorce přepočtů výsledků na různé stavy paliva. [Solid fuels – Symbols of analytical parameters and formulae for converting the results of analyses of different states of fuels.] Prague, Czech Office for Standards, Metrology and Testing.
- ČSN EN 14774-3, 2010. Tuhá biopaliva – Stanovení obsahu vody – Metoda sušení v sušárně – Část 3: Voda v analytickém vzorku pro obecný rozbor. [Solid biofuels – Determination of moisture content – Oven dry method – Part 3: Moisture in general analysis sample.] Prague, Czech Office for Standards, Metrology and Testing.
- ČSN EN 14 918, 2010. Stanovení spalného tepla a výhřevnosti. [Solid biofuels – Determination of calorific value.] Prague, Czech Office for Standards, Metrology and Testing.
- Directive No. 13, 2006. Směrnice MŽP ČR s požadavky pro propůjčení ochranné známky – Teplovodní kotle pro ústřední vytápění na spalování biomasy. [Directive of Ministry of the Environment of the Czech Republic to the requirements for awarding marks – Hot water boilers for central heating systems for biomass.] Prague, Ministry of the Environment of the Czech Republic.
- Directive No. 55, 2008. Směrnice MŽP ČR s požadavky pro propůjčení ochranné známky – Topné pelety z bylinné fytomasy. [Directive of the Ministry of the Environment of the Czech Republic to the requirements for awarding marks – Fuel pellets of herbal of phytomass.] Prague, Ministry of the Environment of the Czech Republic.
- ESKILSSON D., 2004. Optimisation of efficiency and emissions in pellet burners. *Biomass and Bioenergy*, 27: 541–546.
- FIEDLER F., PERSSON T., 2009. Carbon monoxide emissions of combined pellet and solar heating systems. *Applied Energy*, 86: 135–143.
- GÜRDİL G., MALAŤÁK J., SELVÍ K., PINAR Y., 2009. Biomass utilization for thermal energy. *AMA, Agricultural Mechanization in Asia, Africa and Latin America*, 2: 80–85.
- JOHANSSON L.S., LECKNER B., GUSTAVSSON L., COOPER D., TULLIN C., POTTER A., 2004. Emission characteristics of modern and old-type residential boilers fired with wood logs and wood pellets. *Atmospheric Environment*, 38: 4183–4195.
- KHOR A., RYU C., YANG Y.B., SHARIFI V.N., SWITHEBANK J., 2007. Straw combustion in a fixed bed combustor. *Fuel*, 86: 152–160.
- MALAŤÁK J., PASSIAN L., 2011. Heat-emission analysis of small combustion equipments for biomass. *Research in Agricultural Engineering*, 57: 37–50.
- NORDIN A., 1994. Chemical elemental characteristics of biomass fuels. *Biomass and Bioenergy*, 6: 339–347.
- OBERNBERGER I., THEKA G., 2004. Physical characterisation and chemical composition of densified biomass fuels with regard to their combustion behaviour. *Biomass and Bioenergy*, 27: 653–669.
- OLSSON M., KJÄLLSTRAND J., 2006. Low emissions from wood burning in an ecolabelled residential boiler. *Atmospheric Environment*, 6: 1148–1158.
- STREHLER A., 2000. Technologies of wood combustion. *Ecological Engineering*, 16: S25–S40.
- WIHERSAARI M., 2005. Greenhouse gas emissions from final harvest fuel chip production in Finland. *Biomass and Bioenergy*, 5: 435–443.

Received for publication November 9, 2012

Accepted after corrections January 16, 2013

### Corresponding author:

Doc. Ing. JAN MALAŤÁK, Ph.D., Czech University of Life Sciences Prague, Faculty of Engineering, Department of Technological Equipment of Buildings, Kamýcká 129, 165 21 Prague 6-Suchdol, Czech Republic  
phone: + 420 224 383 205, e-mail: malatak@tf.czu.cz