

A Modulation Scheme for 100Gb/s Minimum-Shift Keying Format based on Imbalanced Bias in IQ Components

Li Tao,¹ Yufeng Shao,¹ Junwen Zhang,¹ Jiangbo Zhu,¹ Nan Chi^{*1}

¹Department of Communication Science and Engineering, and State Key Lab of ASIC & System, Fudan University, Shanghai 200433, China
*nanchi@fudan.edu.cn

Abstract: We propose an optical MSK modulation scheme to achieve the 100Gb/s MSK signal with constant envelope and continuous temporal phase shift. The investigation on the transmission performance clearly demonstrates the feasibility of the proposed scheme.

OCIS codes: (060.4080) Modulation; (060.4510) Optical communications.

1. Introduction

The optical Minimum-Shift Keying (MSK) modulation format belongs to the class of continuous-phase modulation. The phase of MSK signal is continuous over time and changes $\pi/2$ during one bit time with the amplitude keeping to a constant value. Due to these features in MSK signal, it exhibits narrower power spectrum when comparing with binary phase-shift keying (BPSK). Several external modulation techniques have been used to achieve higher bit-rate MSK signal [1-5]. One method is to apply triangle signal on the driving signal of the Mach-Zehnder Modulator (MZM) to achieve the desired MSK signal [1]. This scheme, however, has great difficulty to generate a triangle signal in high bit-rate at 100Gb/s and above. While others using sinusoidal signal instead of triangle signal [3, 4], but the optical MSK signal does not have a constant envelope, i.e., the signal power presenting an amplitude fluctuation during certain moment in time domain. To solve this problem, in this paper, we propose a modulation scheme that drive the MZMs with sinusoidal signal and apply imbalanced bias on the MZMs of In-phase and Quadrature components to achieve the MSK signal with constant envelope. In the following sections, we would present the modulation principle, investigate the transmission performance, and compare with the scheme that using the triangle signal and the one using sinusoidal signal with balanced bias.

2. Principle

The setup of optical MSK signal transmitter that proposed in this paper is shown in Fig. 1. The transmitter is based on the Monolithically Integrated Quad-Mach-Zehnder IQ Modulator [3].

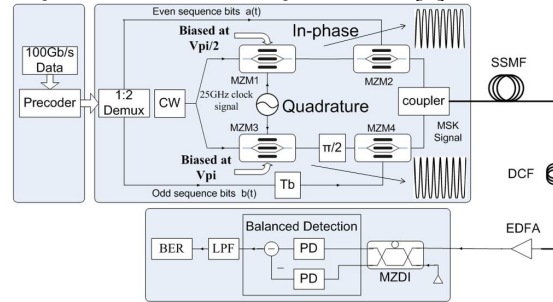

Fig. 1. The setup of MSK signal transmitter using the imbalanced bias scheme.

In our imbalanced bias scheme, the significant change is that MZM1 is biased at $V_{\pi}/2$, while MZM3 is biased at V_{π} , where V_{π} is the electrical voltage that can make π phase shift in one arm of MZM. Also, MZM2 and MZM4 are driven by the modulated even sequence and odd sequence respectively. The output optical signal, shown in insert part in Fig. 1, is CSRZ-DPSK with different duty cycle in the In-phase and Quadrature components. We can achieve the optical MSK signal by coupling the two different CSRZ-DPSK signals.

In the imbalanced bias scheme, the bias voltage of MZM1 is set to $V_{\pi}/2$ in the In-phase component to obtain $\pi/2$ optical phase shift. For the Quadrature component, the bias voltage of MZM3 is set to V_{π} to achieve π optical phase shift. V_{π} is the driving electrical voltage which can cause the π phase shift in an arm of MZM. Then the upper and lower output signal would be coupled, and the optical field of the achieved MSK signal can be given as

$$E_{MSK_novel} = -Ae^{j2\pi f_c t} \cdot \sin\left(\frac{\pi}{2} \sin\left(\frac{\pi}{2T_b} t\right)\right) \cdot \cos(\pi a(t)) - j \cdot Ae^{j2\pi f_c t} \cdot \cos\left(\frac{\pi}{2} \sin\left(\frac{\pi}{2T_b} t\right)\right) \cdot \cos(\pi b(t)). \quad (1)$$

where A is the input optical signal amplitude, f_0 is the laser frequency, T_b is the symbol continuance time, $a(t), b(t)$ are the modulated NRZ signal which convey the input digital information. Obviously, $\cos(\pi a(t))$ and $\cos(\pi b(t))$ would equal 1 or -1. So the output optical MSK signal power and phase in the coupler can be given as

$$P = E_{MSK_novel} \cdot E_{MSK_novel}^* = A^2. \quad (2)$$

$$\tan \varphi = \pm \cot \left(\frac{\pi}{2} \sin \left(\frac{\pi}{2T_b} t \right) \right). \quad (3)$$

We can find that the output signal has constant power and continuous phase temporal shift over time.

In general, the detected bit sequence at the receiver output is not equal to the bit sequence at the transmitter input for the optical MSK signal, so we present a pre-coder corresponding to the proposed MSK modulation scheme. The Fig. 2 shows the state transition diagram, and the following equation, which is achieved from state transition diagram, indicates the logic relationship between the original digital bits and the coded bits,

$$a_0 = q_0$$

$$a_n = \begin{cases} q_n \odot a_{n-1} & n = 4k + 1, 4k + 2 \\ q_n \oplus a_{n-1} & n = 4k + 3, 4k + 4 \end{cases} \quad (k = 1, 2, 3 \dots). \quad (4)$$

where a_n, q_n represent the coded bit sequence and the original bit sequence respectively. The logic symbol “ \odot ” represents XNOR, and “ \oplus ” represents XOR.

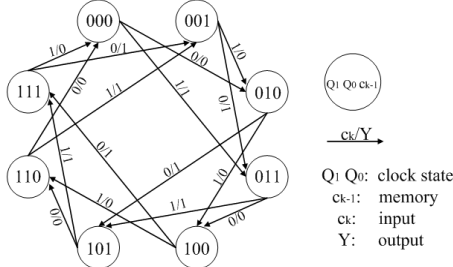

Fig. 2. State-transition diagram for pre-coder.

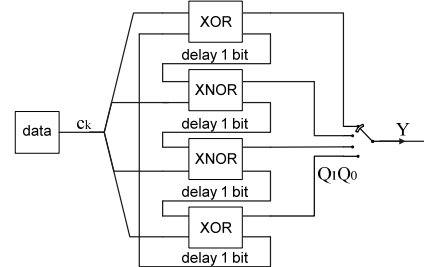

Fig. 3. The pre-coding logic circuit.

According to the Eq. (4) and the state transition diagram, we can design the pre-coding logic circuit, shown in Fig. 3, by using the fundamental logic modules XOR gate and XNOR gate. The output of the logic gate is one input of the next logic gate, then the output of the four logic gates would be in a certain sequence, as a result we can get desired coded bits.

3. Simulations and discussions

Generally, in our simulation system based on the commercial software VPI, the transmission bit-rate is 100Gb/s, the laser frequency is 193.1THz, laser line-width is 150kHz, the fiber link is 20 spans of 50 km SSMF and 8 km DCF, the first and second order dispersion can be compensated completely. The thermal and shot noise, as normally mentioned in optical receivers, are already included in the total equivalent noise current density at the input port of the optical preamplifier in the receiver. Note that, in the following sections, the imbalanced bias scheme represents the scheme that proposed in this paper, and the scheme that using triangle signal and the balanced bias scheme indicates the schemes introduced in [1] and [3] respectively.

First we present the feature of spectrum in different schemes. For better comparison, the result shown in Fig. 4 has been smoothed by using the frequency resolution module in VPI. It can be seen that most signal energy is contained in the main lobe in all spectrum. The slight difference is that the side lobes of the MSK signal generated with balanced bias scheme (blue line) decline a little more slowly than the imbalanced bias scheme (magenta line) and the scheme that using triangle signal (black line).

To evaluate the dispersion tolerance provided by the three schemes, we change the dispersion coefficient of the DCF in the only span. Also, the power input to the only span is set to 0.8mw to neglect the fiber nonlinearity. Fig. 5 shows that the three formats have almost the same resistance to the residual dispersion, and the negative residual dispersion causes a little more power penalty in the imbalanced modulation scheme (magenta line). In our simulation, the power penalty increases fast in the three modulation formats when we change the residual dispersion from 10 ps/nm to 14 ps/nm, for the reason that the increased residual dispersion can have a significant effect on the receiver power penalty when the simulating transmission bit-rate is 100Gb/s. In this point of viewing, these optical MSK modulation formats show the similar capability for residual dispersion tolerance.

To learn about the resistance to the fiber nonlinearity in three schemes, we mainly investigate the SPM tolerance of the MSK signal. In the simulation, the fiber link is 1000km, the first and second dispersion are

compensated completely, and we study the SPM tolerance by changing the average input power of the fiber link. From the Fig. 6 we can find the SPM tolerance of the imbalance bias scheme is 0.5-1.1dB greater than the balance one, for its constant power of generated MSK signal in the transmitter.

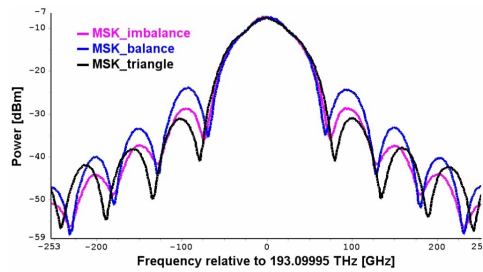

Fig. 4. Comparison of optical MSK signal spectrum in different schemes.

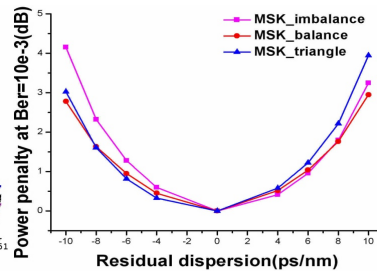

Fig. 5. Positive and negative residual dispersion tolerance in three schemes.

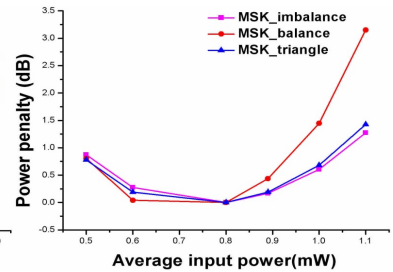

Fig. 6. Nonlinearity of MSK signal in the three schemes.

We measure the bit-error-rate of the three modulation schemes lastly. For fair comparison, we choose the same scheme by using the MZDI to demodulate. According to Fig. 7, we can find that the imbalanced bias scheme (black and green line) has nearly the same Ber performance to the scheme by using triangle signal (red and magenta line), while the balanced bias scheme (blue and wine line) has about 1-2dB power penalty at a Ber of 10^{-6} worse than others. Also, we present the signal locus diagram and the eye pattern in Fig. 8. It can be found that the locus diagram of the MSK signal in the balanced bias scheme is not a circle, for the reason that the power is not constant over time. As a result, the width of eye opening is narrower. With the imbalanced bias scheme, we can get optical MSK signal with constant power and improved Ber performance.

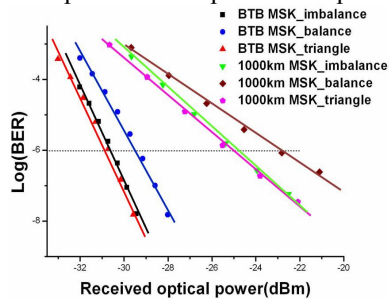

Fig. 7. The measured BER performance in BTB and over 1000km fiber link transmission.

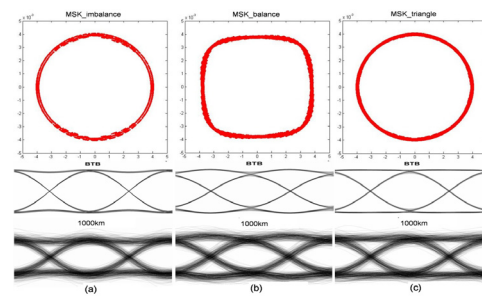

Fig. 8. The locus diagram, BTB and 1000km fiber transmission eye pattern in three schemes, (a) imbalanced bias (b) balanced bias (c) using the triangle signal.

4. Conclusion

In this paper, we propose an optical MSK imbalanced bias modulation scheme and achieve the 100Gb/s optical MSK signal with constant envelope and continuous temporal phase shift by using traditional sinusoidal signal, instead of the triangle signal. The investigation on the spectra, receiver sensitivity, residual dispersion tolerance and SPM tolerance clearly demonstrates the feasibility of the proposed scheme, which can outperform the existing schemes by 2dB receiver power penalty and improve the SPM tolerance by 1-2dB.

5. Acknowledgements

This work is supported by the National Basic Research Program of China (No.2010CB328300), National Natural Science Foundation of China (No.600837004, No.60777010), Hi-Tech Research and Development Program of China (No.2009AA01Z253 and 2009AA01A347), China postdoctoral Science Foundation funded project (No.20090460593), Shanghai postdoctoral Science Foundation funded (No.10R21411600)

6. References

- [1] M. Ohm and J. Speidel, "Optical minimum-shift keying with direct detection (MSK/DD)," Proc. SPIE 5281, 150-161 (2004).
- [2] Jinyu Mo, Yang Jing Wen, Yixin Wang, et al. "Externally Modulated Optical Minimum Shift Keying Format", J. Lightwave Technol., 25(10), 3151-3160 (2007).
- [3] Guo-Wei Lu, Takahide Sakamoto, Akito Chiba, et al., "Optical MSK Transmitter using a Monolithically Integrated Quad Mach-Zehnder IQ Modulator," OFC2009 (Vienna, Austria, 2009), paper 5.2.1.
- [4] Guo-Wei Lu, Takahide Sakamoto, Akito Chiba, et al. "80-Gb/s Optical MSK Generation Using a Monolithically Integrated Quad-Mach-Zehnder IQ Modulator", OFC2010 (San Diego, CA, USA, 2010), paper OWN5.
- [5] Yi Dong, Peigang Hu, Yikai Su, et al., "Generation of 16-Gb/s MSK signal using a single 10-GHz SSB modulator and simplified encoder/decoder," OFC2006 (Anaheim, CA, USA, 2006), paper JThB40.