

# Transmit Isolating Photonic Receive Links : a New Capability for Antenna Remoting

Charles H. Cox, III and Edward I. Ackerman

Photonic Systems, Inc., 900 Middlesex Turnpike, Building #5, Billerica, MA, 01821, USA  
ccox@photonicsinc.com

**Abstract:** We describe a new type of photonic link that replaces the low noise amplifier and circulator of conventional RF front ends, but has > 20 dB greater isolation and > 1000 times broader bandwidth.

**OCIS codes:** (060.2340) Fiber optics components; (280.0280) Remote sensing and sensors

## 1. Introduction

Conventional photonic links have been used to remote the signals received by an antenna [see for example 1]. Typically the sensitivity of such receive-only links was relatively poor, resulting in noise figures > 30 dB [2]. These high noise figures could be overcome by preceding the link with a low noise amplifier (LNA). The penalty to this approach, however, is a reduction in the dynamic range [3]. Recently the RF sensitivity of receive-only photonic links was significantly improved, to the point that no LNA preamplifier is required, which in turn resulted in greater dynamic range [4].

Although there are significant applications for receive-only antenna remoting links, there are also applications for remoting signals in systems that both transmit and receive. Depending on whether full- or half-duplex communication is required, such systems use separate antennas for transmitting and receiving or a single antenna with a transmit/receive switch, respectively, as shown in Figs. 1 (a) and (b). Conceptually an RF circulator could be used to implement full duplex via a single transmit/receive antenna. However, an RF circulator is basically a narrow bandwidth device, to which impedance matching is applied to broaden its bandwidth. Consequently the resulting transmit-to-receive isolation, typically < 20 dB, is achievable over only a fractional bandwidth of 1 octave (2:1).

Conversely, photonics is an inherently broad bandwidth technology, with fractional bandwidths exceeding 1000:1 [5]. It has recently been shown that the broad bandwidth capabilities of photonics can be used to implement a fiber optic link that is capable of providing the two key functions required to implement full-duplex communications via a single antenna:

- High isolation of the receive path from the transmit signal over a broad bandwidth
- Low noise figure and high dynamic range for the receive signal path

This link is unique in that it replaces, functionally, what has traditionally been two RF components: the LNA and circulator. We have therefore given this new type of link a name that describes functionally what it does: transmit isolating photonic receive, or TIPRx for short [6]; see Fig. 1(c) below.

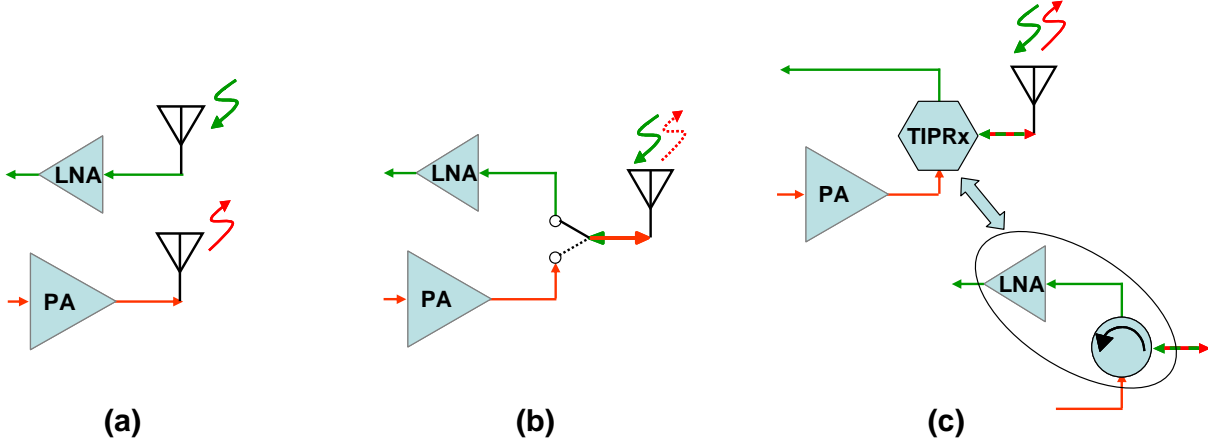

Fig. 1 Block diagrams of antenna remoting front ends: (a) full duplex via two antennas; (b) half duplex via a single antenna and (c) full duplex via single antenna enabled by new transmit isolating photonic receive (TIPRx) link.

In the remainder of this paper we describe two versions of the TIPRx, which can be used separately or in conjunction. Since in previous papers [7] we have focused on the low noise performance aspects of the photonic link on which the TIPRx is based, the focus of this presentation will be on achieving high transmit-receive isolation.

## 2. High frequency TIPRx

The operation and initial performance of this version can be understood with reference to Fig. 2. Figure 2(a) outlines the key operational principle. The receive signal is applied to the TIPRx as it normally would be applied to a traveling wave modulator. However, in a TIPRx the traveling wave electrode is terminated by the output impedance of the transmit source, which would typically be a power amplifier. The TIPRx achieves high sensitivity, i.e. low noise figure, for the receive signal path by maximizing the interaction of the receive signal with the optical carrier, which can be achieved by designing for the velocity match condition: equalization of the RF and optical propagation velocities.

In the TIPRx, the transmit signal is applied to what would normally be the termination-resistance end of the electrode in a conventional traveling wave modulator. The transmit signal then propagates along the electrode and out to the antenna. Since the transmit signal is counter-propagating with respect to the optical carrier, the velocity match between the transmit RF and optical carrier traveling waves is poor. In turn this means that there will be poor modulation efficiency of the optical carrier by the transmit waveform, which is as desired.

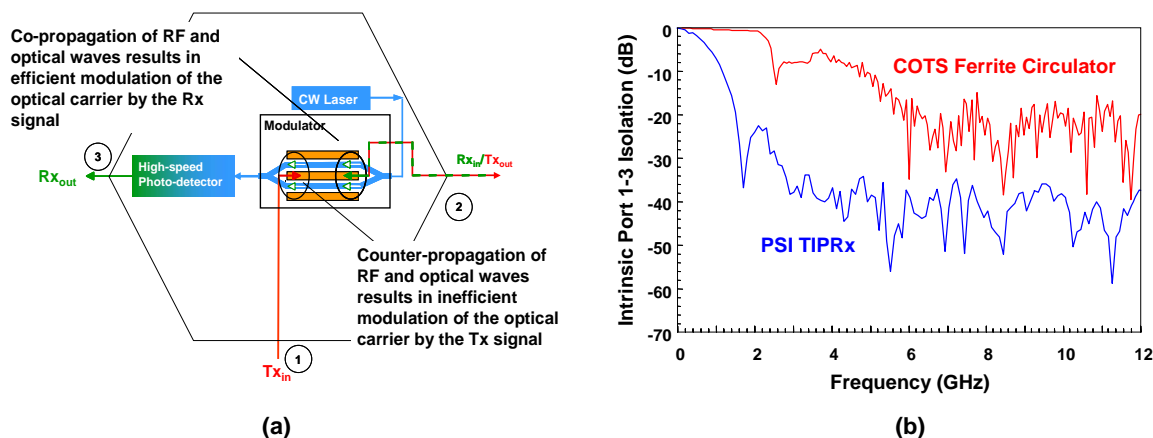

Fig. 2 (a) block diagram of the high frequency TIPRx showing its principal of operation: the co- vs. counter-propagating RF traveling waves with respect to the optical carrier; (b) measured transmit-to-receive isolation of the high frequency TIPRx (blue trace) as compared to a COTS ferrite circulator, both designed to operate from 6 – 12 GHz.

Figure 2(b) is a plot of the measured port 1-3 isolation of the high frequency TIPRx whose operating principle was just discussed. As can be seen from the measured data, the TIPRx is indeed capable of achieving high isolation over a broad bandwidth. For comparison, we also plot in Fig. 2(b) the isolation of a COTS ferrite circulator that was designed to operate from 6 to 12 GHz (an octave being the widest fractional bandwidth of which we are aware for ferrite circulators). Over this bandwidth, the TIPRx has approximately 20 dB greater isolation than the ferrite circulator. The TIPRx also maintains greater isolation to lower frequency than does the ferrite circulator. Below about 1 GHz, however, the difference between the co- and counter propagating receive and transmit waves, respectively, diminishes resulting in diminished isolation. As expected, the high frequency TIPRx isolation approaches 0 dB at low frequencies where traveling wave effects of the TIPRx electrodes become negligible.

## 3. Low frequency TIPRx

The operation and initial performance of this version can be understood with reference to Fig. 3. Figure 3(a) outlines the key operational principle. To achieve broad bandwidth isolation at low frequencies, we need a different operational principle than the traveling waves we used for the high frequency TIPRx. It turns out that a balanced drive optical modulator provides the basis for achieving these objectives.

Recall that in a balanced drive modulator, applying the same signal to both electrodes results in the same optical phase modulation being applied to each arm of the modulator. Hence when these two arms recombine, the result is – at least ideally – no intensity modulation of the optical carrier. In the case of the low frequency TIPRx, we apply the transmit signal to both of the TIPRx drive ports, which results in no modulation being conveyed to the TIPRx

receive output port, as desired. Since the balanced drive operation extends “from dc to daylight” we have – at least in principle – a mechanism for achieving high isolation over a broad bandwidth.

The antenna is connected to only one of the TIPRx drive ports. Consequently the receive signal is applied as an unbalanced drive signal to the TIPRx and therefore it is conveyed to the TIPRx receive output port, again as desired.

Figure 3 (b) is a plot of the measured port 1-3 isolation of the low frequency TIPRx vs. frequency. As can be seen these data confirm the extremely broad bandwidth operation – over 3 *decades* – of the low frequency TIPRx. Similar to its high frequency version, the low frequency TIPRx also has high isolation. Hence this version of the TIPRx has both higher isolation and over a broader bandwidth than a COTS ferrite circulator.

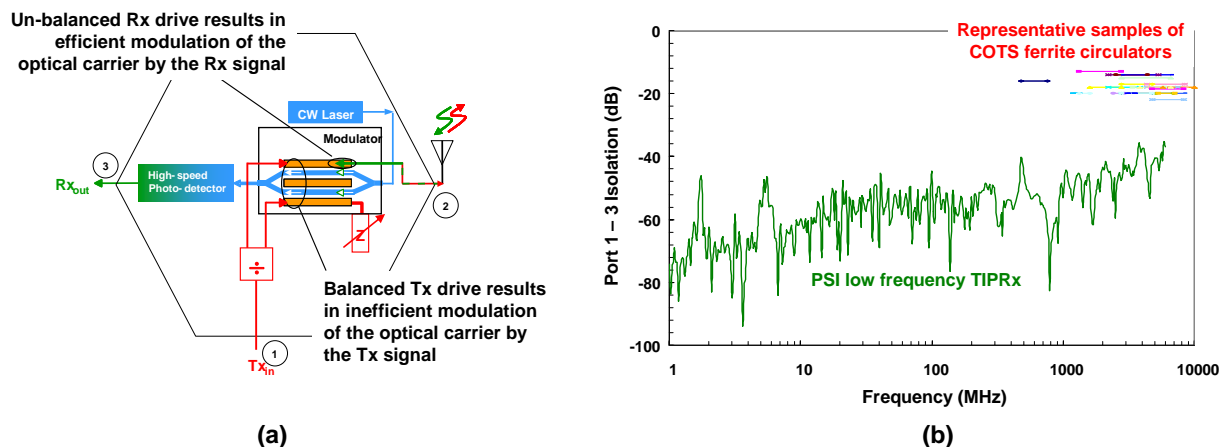

Fig. 3 (a) block diagram of the low frequency TIPRx showing its principle of operation: balanced vs. unbalanced modulation of the optical carrier; (b) measured transmit-to-receive isolation of the low frequency TIPRx vs. frequency.

#### 4. Discussion

As is the case with many designs, there are tradeoffs between the low and high frequency versions of the TIPRx. The low frequency does suffer from wasted transmit power, since the power that drives the TIPRx electrode not connected to the antenna is wasted. The high frequency TIPRx needs no splitter and hence avoids this loss. Having the antenna connected to only one of the low frequency TIPRx electrodes increases the challenge of achieving low receive noise figure as well. The high frequency TIPRx does not sacrifice any receive sensitivity. However, the isolation-bandwidth operation of the low frequency TIPRx is unmatched by any technology, as far as we are aware. And for relatively low power operation, i.e. transmit powers of  $\sim 1$  W or less, the wasted power and slightly higher receive noise figure are trades we have found system designers are willing to accept.

#### 5. References

- [1] E. Ackerman, C. Cox, J. Dreher, M. Davis, and D. DeBoer, “Fiber-optic antenna remoting for radioastronomy applications,” in *Proc. 27th General Assembly, Int. Union of Radio Science* (1997).
- [2] C. Cox and E. Ackerman, “Microwave photonics: past, present and future,” in *Proc. IEEE International Topical Meeting on Microwave Photonics* (2008).
- [3] C. Cox, *Analog Optical Links* (Cambridge University Press, New York, 2004).
- [4] H. Roussel, M. Regan, J. Prince, C. Cox, J. Chen, W. Burns, E. Ackerman, and J. Campbell, “Gain, noise figure, and bandwidth-limited dynamic range of a low-biased external modulation link,” in *Proc. IEEE International Topical Meeting on Microwave Photonics* (2007), pp. 84-87.
- [5] K. Loi, X. Mei, J. Hodiak, C. Tu, and W. Chang, “38GHz bandwidth 1.3 $\mu$ m MQW electroabsorption modulators for RF photonic links,” *Electron. Lett.* **34**, 1018-1019, (1998).
- [6] C. Cox and E. Ackerman, “Photonics for phased array systems,” in *IEEE International Conf. on Phased Array Systems and Technology* (2010).
- [7] E. Ackerman, W. Burns, G. Betts, J. Chen, J. Prince, M. Regan, H. Roussel, and C. Cox, “RF-over-fiber links with very low noise figure,” *JLT* **26**, 2441-2448 (2008).