

Four-wave mixing-based wavelength conversion in a Short-Length of a Solid 1D Microstructured Fibre

Angela Camerlingo, Francesca Parmigiani, Xian Feng, Francesco Poletti, Peter Horak,
Wei H. Loh, David J. Richardson and Periklis Petropoulos

Optoelectronics Research Centre, University of Southampton, Southampton, SO17 1BJ, UK
Email: anc@orc.soton.ac.uk

Abstract We demonstrate a four-wave mixing based wavelength conversion scheme at 1.55 μm in a 1.5m long highly nonlinear, dispersion tailored one-dimensional (1D) soft glass microstructured optical fibre.

Introduction

The use of soft glasses for the fabrication of microstructured optical fibres (MOFs) and the ability to tailor their dispersion profile have opened up new opportunities for the realization of compact highly nonlinear devices. Among the nonlinear processes, optical parametric effects based on four-wave-mixing (FWM) play an essential role in the realization of many devices, including all-optical wavelength converters [1]. In general, the most important fibre parameters that contribute towards achieving efficient and broadband FWM are a high nonlinear coefficient, a low dispersion, low dispersion slope and a short fibre length [2]. Soft-glass holey fibres have already been demonstrated as good candidates for FWM processes (see e.g. [3]). However, to achieve the accurate dispersion control required places onerous demands on the level of structural control needed for the complex 'holey' microstructure (both transversally and longitudinally down the fibre). One way to improve the situation is to move to all-solid 1D MOFs since the microstructure geometry is defined in this case during manufacture of the macroscopic solid preform rather than during the delicate fibre draw process [3].

Recently, we have reported the fabrication of a highly nonlinear 1D MOF based on two commercial glasses (Schott SF6 and LLF1) which exhibits the lowest reported value of losses, while maintaining a high nonlinear coefficient and low dispersion values at telecommunications wavelengths [3]. In this paper, we demonstrate the use of this fibre to realise a compact (1.5 m long) FWM-based wavelength converter operating at 1.55 μm . Eye-diagrams and bit-error rate (BER) curves confirm the high signal quality achieved in the conversion process.

Experimental set-up and results

The experimental setup for the FWM-based wavelength converter is shown in Fig. 1. The converter was based on a 1D MOF that exhibited a high refractive index core surrounded by alternating high and low index rings. The high index glass was Schott SF6 ($n=1.76$ @ 1550 nm) while Schott LLF1 glass ($n=1.53$ @ 1550 nm) was used for the low index

rings. The core diameter was $\sim 3.7 \mu\text{m}$, while the thickness of the surrounding layers varied in the range 0.3 to 1.1 μm [4]. This fibre showed effective single mode guidance at 1.55 μm and its propagation loss was measured to be $\sim 0.8 \pm 0.2 \text{ dB/m}$ using the cut-back method. This is the lowest reported value for a non-silica MOF at telecoms wavelengths so far.

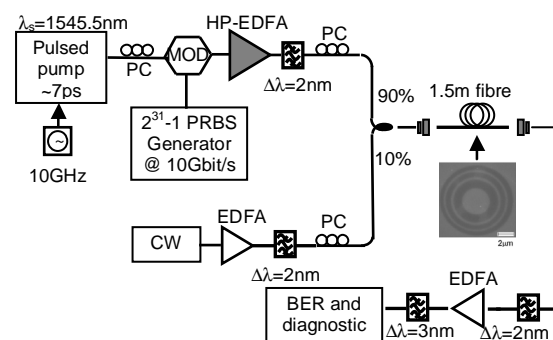

Fig. 1: Experimental setup. PC: polarization controller

Using the Boskovic method [5], the nonlinear coefficient of the fibre was measured to be $\sim 120 \text{ W}^{-1}\text{km}^{-1}$. Numerical simulations on the dispersion profile of the fabricated fibre show a dispersion slope of $0.15 \text{ ps/nm}^2/\text{km}$ at 1.55 μm ; this value is largely insensitive to any small structural variations. Using the FWM method, the dispersion of the fibre was measured to be 12.5 ps/nm/km at 1.55 μm . The zero dispersion wavelength (ZDW) of this fibre is therefore estimated to be $\sim 1.47 \mu\text{m}$.

The pump signal to the FWM-based wavelength converter was generated by a 10GHz mode locked laser, which produced $\sim 7\text{ps}$ full-width-half-maximum (FWHM) pulses at 1545nm. The pulses were amplitude modulated by a $2^{31}-1$ pseudorandom bit sequence (PRBS) using a lithium-niobate Mach-Zehnder modulator (MOD) and amplified using a high power erbium-doped fibre amplifier (HP-EDFA). A band pass filter (BPF) was used to reject any undesired amplified spontaneous emission (ASE) noise arising from the HP-EDFA. The probe signal was generated by a continuous wave (CW) tuneable laser, amplified and filtered to reject any out-of-band ASE noise. Note that two different amplifiers were used to independently control the powers of the two

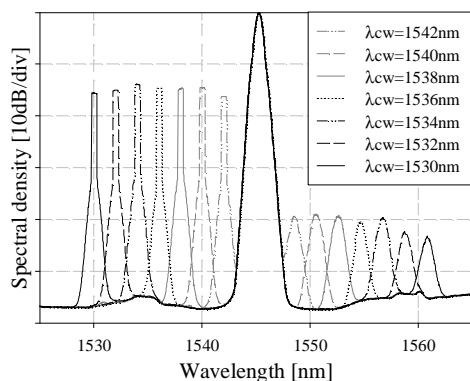

Fig. 2: Spectral traces at the output of the 1D MOF for various input CW signal wavelengths (Resolution = 0.5nm).

signals. Polarization controllers (PCs) were used to align the state of polarization of the two beams to the polarization axis of the 1D MOF. The pump pulses and the CW signal were then combined in a 90/10 coupler and free-space launched into 1.5 m of fibre with a coupling efficiency of $\sim 35\%$. The average powers of the pump and the signal at the very input of the fibre were 24.5 dBm and 3 dBm respectively.

Under conditions of phase matching, the gain and the pulse shape of the signal and the idler depend on the pump pulse shape and peak power as well as the fibre parameters. Owing to the low loss, low dispersion and the high nonlinearity per unit length of the MOF, we have observed optical parametric generation of pulses over a range of wavelengths that cover the upper part of the C-band in our experiments, even if the pump wavelength sits far away from the ZDW. This is illustrated in Fig. 2, which shows the spectral traces at the output of the system when the CW wavelength was tuned from 1542nm to 1530nm. The Figure shows that an optical signal to noise ratio (OSNR) of ~ 12 -18 dB has been achieved at the output of the system. It is worth noting however, that this is mainly limited by the dynamic range of the spectrum analyser, and in reality the OSNR was much higher than this (the BER measurements presented below are in support of this argument). The conversion efficiency (which depends on the power of both the pump and signal waves) varies by ~ 4.5 dB across this 12-nm tuning range. The Figure also shows newly generated frequency components around the CW wavelengths, which are due to the combined effects of cross-phase modulation and parametric amplification.

We then filtered and further characterised the parametrically generated pulses at one particular wavelength ($\lambda_{\text{idler}} = 1552$ nm) in terms of their noise properties and pulse width. The insets in Fig.3 show eye diagrams obtained at the input and the output of the system, respectively. A very clean eye diagram with very low intensity noise is obtained at the output

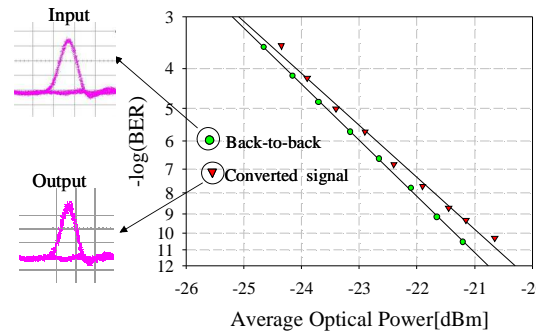

Fig. 3: BER measurements at the input (back-to-back) and output of the system. Inset: Corresponding eye diagrams.

of the FWM wavelength converter, confirming a good OSNR for the generated FWM component. The high quality of the eye diagram is reflected in the corresponding BER measurement shown in Fig.3. The wavelength converted signal has a power penalty of ~ 0.5 dB as compared to the input signal at BER = 10^{-9} (error-free operation). Finally, we have measured autocorrelation traces of the input/output signals (the results are not reported here) and observed an output signal pulse reduction from 7ps to 4.8ps (e.g. as discussed in [7]). These values have also been predicted from simulations on our wavelength conversion system.

Conclusions

We have successfully demonstrated the use of a recently fabricated soft glass 1D MOF in a FWM-based wavelength converter. The fibre shows a high nonlinear coefficient, low dispersion and dispersion slope and the lowest value of losses reported so far for a non-silica fibre at telecommunication wavelengths. Using a sample of only 1.5m length we have demonstrated FWM-based wavelength conversion over a wide range of wavelengths even when the pump signal sits at wavelengths relatively far from the fibre ZDW. We envisage that further improvements in the fabrication of 1D MOFs will yield significant benefits in both the conversion efficiency and the bandwidth of parametric devices based on this technology.

This work was partially funded by the European Commission STREP project PHASORS (FP7-ICT-2007-2 22457) and NoE BONE (FP7-ICT-2007-1 216863).

References

- 1 M.N. Islam et al., IEEE JST-QE, 8, (2002), 527.
- 2 J. Hansryd et al., IEEE JST-QE, 8, (2002), 506.
3. Asimakis et al., Opt. Exp., 15,(2007), 596-601.
- 4 X. Feng et al., CLEO/Europe 2009, CE3.4.
- 5 A.Boskovic et al., Opt. Lett., 21, (1996) 1966.
- 6 T. Hasegawa et al. Opt. Comm. (2008), 281, 782.
- 7 T. Torounidis, et al., IEEE J. Lightwave Technol. (23), (2005), 4067-4073.