

Quantum Cryptanalysis on Some Generalized Feistel Schemes

LI Zheng¹, DONG XiaoYang^{2*} & WANG Xiaoyun^{1,2*}

¹Key Laboratory of Cryptologic Technology and Information Security, Ministry of Education,
Shandong University, P. R. China;

²Institute for Advanced Study, Tsinghua University, P. R. China
{xiaoyangdong,xiaoyunwang}@tsinghua.edu.cn

Received ; accepted

Abstract Post-quantum cryptography has attracted much attention from worldwide cryptologists. In ISIT 2010, Kuwakado and Morii gave a quantum distinguisher with polynomial time against 3-round Feistel networks. However, generalized Feistel schemes (GFS) have not been systematically investigated against quantum attacks. In this paper, we study the quantum distinguishers about some generalized Feistel schemes. For d -branch Type-1 GFS (CAST256-like Feistel structure), we introduce $(2d-1)$ -round quantum distinguishers with polynomial time. For $2d$ -branch Type-2 GFS (RC6/CLEFIA-like Feistel structure), we give $(2d+1)$ -round quantum distinguishers with polynomial time. Classically, Moriai and Vaudenay proved that a 7-round 4-branch Type-1 GFS and 5-round 4-branch Type-2 GFS are secure pseudo-random permutations. Obviously, they are no longer secure in quantum setting.

Using the above quantum distinguishers, we introduce generic quantum key-recovery attacks by applying the combination of Simon's and Grover's algorithms recently proposed by Leander and May. We denote n as the bit length of a branch. For $(d^2 - d + 2)$ -round Type-1 GFS with d branches, the time complexity is $2^{(\frac{1}{2}d^2 - \frac{3}{2}d + 2) \cdot \frac{n}{2}}$, which is better than the quantum brute force search (Grover search) by a factor $2^{(\frac{1}{4}d^2 + \frac{1}{4}d)n}$. For $4d$ -round Type-2 GFS with $2d$ branches, the time complexity is $2^{\frac{d^2 n}{2}}$, which is better than the quantum brute force search by a factor $2^{\frac{3d^2 n}{2}}$.

Keywords Generalized Feistel Schemes, Simon, Grover, CAST-256, RC6, CLEFIA

Citation LI Z, Dong X Y, Wang X Y. Quantum Cryptanalysis on Some Generalized Feistel Schemes. Sci China Inf Sci, 2016, (): xxxxxx, doi: xxxxxxxxxxxxxxxx

1 Introduction

It is well known that several public key cryptosystem standards, such as RSA and ECC, have been broken by Shor's algorithm [Sho97] with a quantum computer. Recently, researchers find that quantum computing not only impacts the public key cryptography, but also could break many secret key schemes, which includes the key-recovery attacks against Even-Mansour ciphers [KM12], distinguishers against 3-round Feistel networks [KM10], key-recovery and forgery attacks on some MACs and authenticated encryption ciphers [KLLN16], key-recovery attacks against FX constructions [LM17], and others. So to

* Corresponding author (email: xiaoyangdong@tsinghua.edu.cn, xiaoyunwang@tsinghua.edu.cn)

Table 1 Results on Type-1 (CAST256-like) GFS in Quantum Settings

Branches $d \geq 3$	Distinguisher Round $2d - 1$	Key-recovery Rounds	Complexity (\log)	Trivial Bound (\log)
		$r_0 = d^2 - d + 2$	$(\frac{1}{2}d^2 - \frac{3}{2}d + 2) \cdot \frac{n}{2}$	$\frac{(d^2 - d + 2)n}{2}$
	$r > r_0$	$(\frac{1}{2}d^2 - \frac{3}{2}d + 2) \cdot \frac{n}{2} + \frac{(r - r_0)n}{2}$	$\frac{rn}{2}$	

study the security of more classical and important cryptographic schemes against quantum attacks is urgently needed. At Asiacrypt 2017, NIST [TP17] reports the ongoing competition for post-quantum cryptographic algorithms, including signatures, encryptions and key-establishment. The ship for post-quantum crypto has sailed, cryptographic communities must get ready to welcome the post-quantum age.

In a quantum computer, the adversaries could make quantum queries on some superposition quantum states of the relevant cryptosystem, which is the so-called quantum-CPA setting [BZ13]. It is known that Grover's algorithm [Gro96] could speed up brute force search. Given an m -bit key, Grover's algorithm allows to recover the key using $\mathcal{O}(2^{m/2})$ quantum steps. It seems that doubling the key-length of one block cipher could achieve the same security against quantum attackers. However, Kuwakado and Morii [KM12] identified a new family of quantum attacks on certain generic constructions of secret key schemes. They showed that the Even-Mansour ciphers could be broken in polynomial time by Simon algorithm [Sim97], which could find the period of a periodic function in polynomial time in a quantum computer. The following works by Kaplan *et al.* [KLLN16] revealed that many other secret key schemes could also be broken by Simon algorithm, such as CBC-MAC, PMAC, GMAC and some CAESAR candidates.

Feistel block ciphers [FNS75] are extremely important and extensively researched cryptographic schemes. It adopts an efficient Feistel network design. Historically, many block cipher standards such as DES, Triple-DES, MISTY1, Camellia and CAST-128 [Int10] are based on Feistel design. At CRYPTO 1989, Zheng *et al.* [ZMI90] summarised some generalized Feistel schemes (GFS) as Type-1/2/3 GFS. Many block ciphers are based on GFS designs. CAST-256 is based on Type-1 GFS, CLEFIA and RC6 are based on Type-2 GFS, MARS is based on Type-3 GFS, so Type-1/2/3 GFS are also denoted as CAST256-like Feistel scheme, RC6/CLEFIA-like Feistel scheme, and MARS-like Feistel scheme [MV00]. Chinese standard block cipher SMS4 is based on a different contracting Feistel scheme, we denote it as SMS4-like GFS.

In a seminal work, Luby and Rackoff [LR88] proved that a three-round Feistel scheme is a secure pseudo-random permutation. However, Kuwakado and Morii [KM10] introduced a quantum distinguisher attack on 3-round Feistel ciphers, that could distinguish the cipher and a random permutation in polynomial time. At Asiacrypt 2000, Moriai and Vaudenay [MV00] studied some generalized Feistel schemes (GFS) and proved a 7-round 4-branch CAST256-like GFS and 5-round 4-branch RC6/CLEFIA-like GFS are secure pseudo-random permutations. Quantum distinguishers against those generalized Feistel schemes are missing.

In this paper, we study the quantum distinguisher attacks on Type-1 GFS (CAST256-like), Type-2 GFS (RC6/CLEFIA-like) and others. For d -branch Type-1 GFS, we introduce $(2d - 1)$ -round quantum distinguishers with polynomial time. For $2d$ -branch Type-2 GFS (RC6/CLEFIA-like Feistel structure), we give $(2d + 1)$ -round quantum distinguishers with polynomial time. Classically, Moriai and Vaudenay [MV00] proved that a 7-round 4-branch Type-1 GFS and 5-round 4-branch Type-2 GFS are secure pseudo-random permutations. Obviously, they are no longer secure in quantum setting. Denote the branch size as n . We introduce generic quantum key-recovery attacks on Type-1 and Type-2 GFS by applying the combination of Simon's and Grover's algorithms recently proposed by Leander and May. As shown in Table 1, for $(d^2 - d + 2)$ -round Type-1 GFS with d branches, the time complexity is $2^{(\frac{1}{2}d^2 - \frac{3}{2}d + 2) \cdot \frac{n}{2}}$, which is better than the quantum brute force search (Grover search) by a factor $2^{(\frac{1}{4}d^2 + \frac{1}{4}d)n}$. As shown in Table 2, for $4d$ -round Type-2 GFS with $2d$ branches, the time complexity is $2^{\frac{d^2 n}{2}}$, which is better than the quantum brute force search by a factor $2^{\frac{3d^2 n}{2}}$.

Table 2 Results on Type-2 (RC6/CLEFIA-like) GFS in Quantum Settings

Branches $2d \geq 4$	Distinguisher Round $2d + 1$	Key-recovery Rounds	Complexity (\log)	Trivial Bound (\log)
		$r_0 = 4d$	$\frac{d^2}{2}n$	$2d^2n$
		$r > r_0$	$\frac{d^2 + (r - r_0)d}{2}n$	$\frac{rdn}{2}$

2 Preliminaries

2.1 Related Works

Our quantum attacks are based the two popular quantum algorithms, i.e. Simon algorithm [Sim97] and Grover algorithm [Gro96].

Simon's Problem. Given a boolean function $f: \{0, 1\}^n \rightarrow \{0, 1\}^n$, that is known to be invariant under some n -bit XOR period a , find a . In other words, find a by given: $f(x) = f(y) \leftrightarrow x \oplus y \in \{0^n, a\}$.

Classically, the optimal time to solve the problem is $\mathcal{O}(2^{n/2})$. However, Simon [Sim97] gives a quantum algorithm that provides exponential speedup and only requires $\mathcal{O}(n)$ quantum queries to find a . The algorithm includes five quantum steps:

- I. Initializing two n -bit quantum registers to state $|0\rangle^{\otimes n}|0\rangle^{\otimes n}$, one applies Hadamard transform to the first register to attain an equal superposition:

$$H^{\otimes n}|0\rangle|0\rangle = \frac{1}{\sqrt{2^n}} \sum_{x \in \{0,1\}^n} |x\rangle|0\rangle. \quad (1)$$

- II. A quantum query to the function f maps this to the state

$$\frac{1}{\sqrt{2^n}} \sum_{x \in \{0,1\}^n} |x\rangle|f(x)\rangle$$

- III. Measuring the second register, the first register collapses to the state:

$$\frac{1}{\sqrt{2}}(|z\rangle + |z \oplus a\rangle)$$

- IV. Applying Hadamard transform to the first register, we get:

$$\frac{1}{\sqrt{2}} \frac{1}{\sqrt{2^n}} \sum_{y \in \{0,1\}^n} (-1)^{y \cdot z} (1 + (-1)^{y \cdot a}) |y\rangle$$

- V. The vectors y such that $y \cdot a = 1$ have amplitude 0. Hence, measuring the state yields a value y that $y \cdot a = 0$.

Repeat $\mathcal{O}(n)$ times, one obtains a by solving a system of linear equations.

Kuwakado and Morii [KM10] introduced a quantum distinguish attack on 3-round Feistel scheme by using Simon algorithm. As shown in Figure 1, α_0 and α_1 are arbitrary constants:

$$\begin{aligned} f: \{0, 1\} \times \{0, 1\}^n &\rightarrow \{0, 1\}^n \\ b, x &\mapsto \alpha_b \oplus x_2^3, \text{ where } (x_1^3, x_2^3) = E(\alpha_b, x) \\ f(b, x) &= R_2(R_1(\alpha_b) \oplus x) \end{aligned}$$

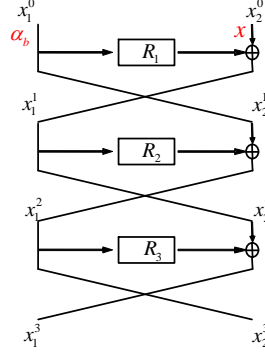

Figure 1 3-round Quantum Distinguisher

f is periodic function that $f(b, x) = f(b \oplus 1, x \oplus R_1(\alpha_0) \oplus R_1(\alpha_1))$. Then using Simon's algorithm, one can get the period $s = 1 ||R_1(\alpha_0) \oplus R_1(\alpha_1)$ in polynomial time.

Grover's Algorithm. The task is to find a marked element from a set X . We denote by $M \subseteq X$ the subset of marked elements. Classically, one solve the problem with time $|X|/|M|$. However, in a quantum computer, the problem is solve with high probability in time $\sqrt{|X|/|M|}$ using Grover's algorithm. The steps of the algorithm is as follows:

- I. Initializing a n -bit register $|0\rangle^{\otimes n}$. One applies Hadamard transform to the first register to attain an equal superposition:

$$H^{\otimes n}|0\rangle = \frac{1}{\sqrt{2^n}} \sum_{x \in \{0,1\}^n} |x\rangle = |\varphi\rangle. \quad (2)$$

- II. Construct an oracle $\mathcal{O}: |x\rangle \xrightarrow{\mathcal{O}} (-1)^{f(x)}|x\rangle$, where $f(x) = 1$ if x is the correct state, and $f(x) = 0$ otherwise.

- III. Apply Grover iteration for $R \approx \frac{\pi}{4}\sqrt{2^n}$ times:

$$[(2|\varphi\rangle\langle\varphi| - I)\mathcal{O}]^R|\varphi\rangle \approx |x_0\rangle$$

- IV. return x_0 .

Later, Brassard *et al.* [BHMT00] generalized the Grover search as amplitude amplification.

Theorem 1. (Brassard, Hoyer, Mosca and Tapp [BHMT00]). Let \mathcal{A} be any quantum algorithm on q qubits that uses no measurement. Let $\mathcal{B}: \mathbb{F}_2^q \rightarrow \{0, 1\}$ be a function that classifies outcomes of \mathcal{A} as good or bad. Let $p > 0$ be the initial success probability that a measurement of $\mathcal{A}|0\rangle$ is good. Set $k = \lceil \frac{\pi}{4\theta} \rceil$, where θ is defined via $\sin^2(\theta) = p$. Moreover, define the unitary operator $Q = -\mathcal{A}S_0\mathcal{A}^{-1}S_{\mathcal{B}}$, where the operator $S_{\mathcal{B}}$ changes the sign of the good state

$$|x\rangle \mapsto \begin{cases} -|x\rangle & \text{if } \mathcal{B}(x) = 1, \\ |x\rangle & \text{if } \mathcal{B}(x) = 0, \end{cases}$$

while S_0 changes the sign of the amplitude only for the zero state $|0\rangle$. Then after the computation of $Q^k\mathcal{A}|0\rangle$, a measurement yields good with probability a least $\max\{1-p, p\}$.

Assuming $|\varphi\rangle = \mathcal{A}|0\rangle$ is the initial vector, whose projections on the good and the bad subspace are denoted $|\varphi_1\rangle$ and $|\varphi_0\rangle$. The state $|\varphi\rangle = \mathcal{A}|0\rangle$ has angle θ with the bad subspace, where $\sin^2(\theta) = p$. Each Q iteration increase the angle to 2θ . Hence, after $k \approx \frac{\pi}{4\theta}$, the angle roughly equals to $\pi/2$. Thus, the state after k iterations is almost orthogonal to the bad subspace. After measurement, it produces the good vector with high probability.

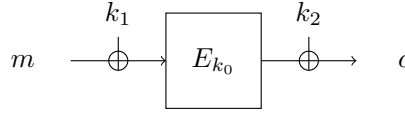
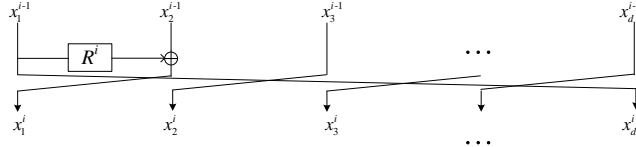

Figure 2 FX constructions

Figure 3 Round i of CAST256-like GFS with d Branches

At Asiacrypt 2017, Leander and May [LM17] gave a quantum key-recovery attack on FX-construction shown in Figure 2: $Enc(x) = E_{k_0}(x + k_1) + k_2$. They introduce the function $f(k, x) = Enc(x) + E_k(x) = E_{k_0}(x + k_1) + k_2 + E_k(x)$. For the correct key guess $k = k_0$, we have $f(k, x) = f(k, x + k_1)$ for all x . However, for $k \neq k_0$, $f(k, \cdot)$ is not periodic. They combine Simon and Grover algorithm to attack FX ciphers (such as PRINCE [BCG⁺12], PRIDE [ADK⁺14], DESX) in the quantum-CPA model with complexity roughly 2^{32} .

2.2 Notations

- x_j^0 the j th branch in the input;
- x_j^i the j th branch in the output of i th round, $i \geq 1, j \geq 1$;
- d the branch number of CAST256-like GFS;
- $2d$ the branch number of RC6/CLEFIA-like GFS;
- n the bit length of a branch;
- R^i the i th ($i \geq 1$) round function of Type-1 (CAST256-like) GFS, the input and output are n -bit string, n -bit key is absorbed by R^i ;
- R_j^i the j th ($1 \leq j \leq d$) round function in the i th ($i \geq 1$) round function of Type-2 (RC6/CLEFIA-like) GFS, the input and output are n -bit string, n -bit key is absorbed by R_j^i .

3 Quantum Cryptanalysis on Type-1 (CAST256-like) GFS

3.1 Quantum Distinguishers on Type-1 (CAST256-like) GFS

As shown in Figure 3, the input of the cipher is divided into d branches, i.e. x_j^0 for $1 \leq j \leq d$, each of which has n -bit, so the blocksize is $d \times n$. R^i is the round function that absorbs n -bit secret key and n -bit input. We construct the corresponding quantum distinguisher on the $(2d - 1)$ -round cipher.

The intermediate state after the i th round is x_j^i for $1 \leq j \leq d$, especially the output of the $(2d - 1)$ th round is denoted as $x_1^{2d-1} || x_2^{2d-1} || \dots || x_d^{2d-1}$. For the input of round function R^d , we compute its symbolic expression with x_j^0 for $1 \leq j \leq d$:

$$R^{d-1}(R^{d-2}(\dots R^3(R^2(R^1(x_1^0) \oplus x_2^0) \oplus x_3^0) \dots \oplus x_{d-2}^0) \oplus x_{d-1}^0) \oplus x_d^0 \quad (3)$$

Similarly, the output of round function R^d is $x_1^0 \oplus x_2^{2d-1}$. Thus, we get the following equation:

$$R^d(R^{d-1}(R^{d-2}(\dots R^3(R^2(R^1(x_1^0) \oplus x_2^0) \oplus x_3^0) \dots \oplus x_{d-2}^0) \oplus x_{d-1}^0) \oplus x_d^0) = x_1^0 \oplus x_2^{2d-1} \quad (4)$$

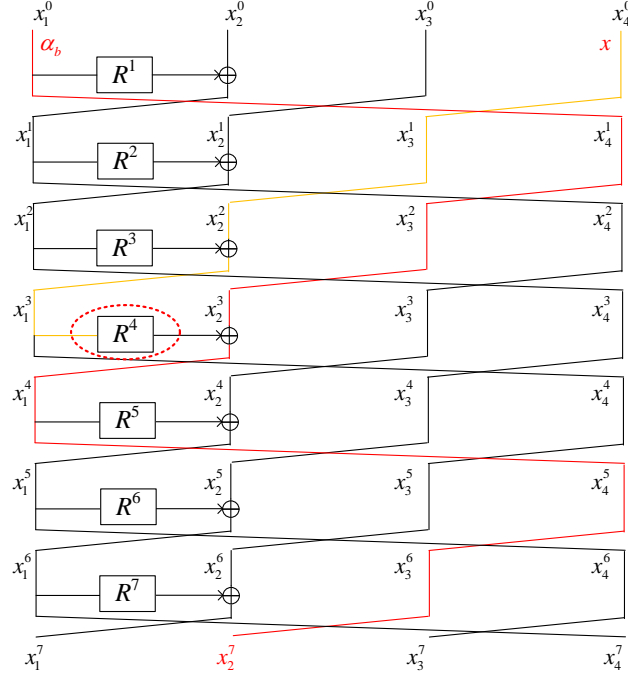

Figure 4 7-round Distinguisher on CAST256-like GFS with $d = 4$

In Equation (4), let $x_1^0 = \alpha_b$ ($b = 0, 1$, α_0, α_1 are arbitrary constants, $\alpha_0 \neq \alpha_1$), $x_d^0 = x$, and all of $x_1^0, x_2^0, \dots, x_d^0$ be constants, we get

$$R^d(R^{d-1}(R^{d-2}(\dots R^3(R^2(R^1(\alpha_b) \oplus x_2^0) \oplus x_3^0) \dots \oplus x_{d-2}^0) \oplus x_{d-1}^0) \oplus x) = \alpha_b \oplus x_2^{2d-1} \quad (5)$$

Denote $h(\alpha_b) = R^{d-1}(R^{d-2}(\dots R^3(R^2(R^1(\alpha_b) \oplus x_2^0) \oplus x_3^0) \dots \oplus x_{d-2}^0) \oplus x_{d-1}^0)$, then Equation (5) becomes $R^d(h(\alpha_b) \oplus x) = \alpha_b \oplus x_2^{2d-1}$. We construct function f as following:

$$\begin{aligned} f : \{0, 1\} \times \{0, 1\}^n &\rightarrow \{0, 1\}^n \\ b, x &\mapsto \alpha_b \oplus x_2^{2d-1}, \text{ where } x_1^{2d-1} \parallel x_2^{2d-1} \parallel \dots \parallel x_d^{2d-1} = E(\alpha_b, x) \\ f(b, x) &= R^d(h(\alpha_b) \oplus x) \end{aligned}$$

So $f(0, x) = f(1, x \oplus h(\alpha_0) \oplus h(\alpha_1)) = R_d(h(\alpha_0) \oplus x)$, $f(1, x) = f(0, x \oplus h(\alpha_0) \oplus h(\alpha_1)) = R_d(h(\alpha_1) \oplus x)$. Thus $f(b, x) = f(b \oplus 1, x \oplus h(\alpha_0) \oplus h(\alpha_1))$. Therefore, function f satisfies Simon's promise with $s = 1 \parallel h(\alpha_0) \oplus h(\alpha_1)$.

Example Case of Type-1 (CAST256-like) with $d = 4$:

When $d = 4$, we get 7-round quantum distinguisher as shown in Figure 4. Thus, $h(\alpha_b) = R^3(R^2(R^1(\alpha_b) \oplus x_2^0) \oplus x_3^0)$, where x_2^0 and x_3^0 are constants.

3.2 Quantum Key-recovery Attacks on Type-1 (CAST256-like) GFS

We first study the quantum key-recovery attack on CAST256-like GFS with $d = 4$ branches. Following the similar idea that combines Simon's and Grover's algorithms to attack Feistel structure [DW17], we append 7 rounds under the 7-round distinguisher to launch the attack. As shown in Figure 5, there are $4n$ -bit key needed to be guessed by Grover's algorithm, which are highlighted in the red boxes of round functions. Thus, the 14-round quantum key-recovery attack needs about 2^{2n} time and $\mathcal{O}(n^2)$ qubits. If we attack $r > 14$ rounds, we need guess $4n + (r - 14)n$ key bits by Grover's algorithm. Thus, the time complexity is $2^{2n + \frac{(r-14)n}{2}}$.

Generally, for $d \geq 3$, we could get $(2d - 1)$ -round quantum distinguisher. We append $d^2 - 3d + 3$ rounds under the quantum distinguisher to attack $r_0 = d^2 - d + 2$ rounds CAST256-like GFS. Similarly, we need

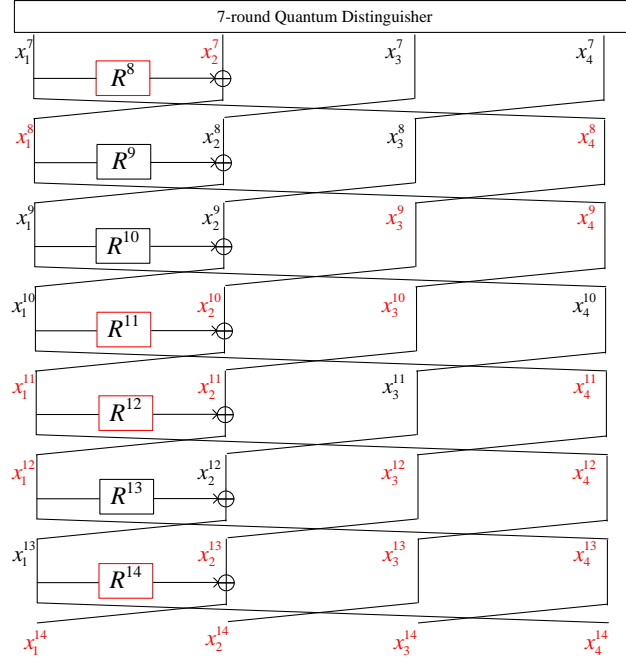

Figure 5 14-round Quantum Key-recovery Attack on CAST256-like GFS with $d = 4$

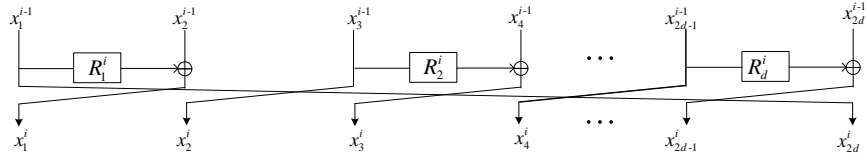

Figure 6 Round i of RC6/CLEFIA-like GFS with $2d$ Branches

to guess $(\frac{1}{2}d^2 - \frac{3}{2}d + 2)n$ -bit key by Grover's algorithm. Thus, for r_0 rounds, the time complexity is $(\frac{1}{2}d^2 - \frac{3}{2}d + 2) \cdot \frac{n}{2}$ queries, and $\mathcal{O}(n^2)$ qubits are needed. If we attack $r > r_0$ rounds, we need guess $(\frac{1}{2}d^2 - \frac{3}{2}d + 2)n + (r - r_0)n$ key bits by Grover's algorithm. Thus, the time complexity is $2^{(\frac{1}{2}d^2 - \frac{3}{2}d + 2) \cdot \frac{n}{2} + \frac{(r - r_0)n}{2}}$.

If we use the quantum brute force search (Grover search) to recover the key, for r -round d -branch cipher, totally, rn -bit key need to be found, the complexity is $2^{rn/2}$. Thus, our attack is better than the quantum brute force search (Grover search) by a factor $2^{rn/2 - ((\frac{1}{2}d^2 - \frac{3}{2}d + 2) \cdot \frac{n}{2} + \frac{(r - r_0)n}{2})} = 2^{(\frac{1}{4}d^2 + \frac{1}{4}d)n}$.

4 Quantum Cryptanalysis on Type-2 (RC6/CLEFIA-like) GFS

4.1 Quantum Distinguishers on Type-2 (RC6/CLEFIA-like) GFS

As shown in Figure 6, the input of the cipher is divided into $2d$ branches, i.e. x_j^0 for $1 \leq j \leq 2d$, each of which has n -bit, so the blocksize is $2d \times n$. R_l^i ($1 \leq l \leq d$) is the l th round function in i th round that absorbs n -bit secret key and n -bit input. We construct the corresponding quantum distinguisher on the $(2d + 1)$ -round cipher.

The intermediate state after the i th round is x_j^i for $1 \leq j \leq 2d$, especially the output of the $(2d + 1)$ th round is denoted as $x_1^{2d+1} || x_2^{2d+1} || \dots || x_{2d}^{2d+1}$.

Case Study, $2d = 4$:

As shown in Figure 7 with $2d = 4$, for the input of round function R_1^4 about x_j^0 for $1 \leq j \leq 4$, we compute its symbolic expression: $R_1^3(R_2^2(R_1^1(x_1^0) \oplus x_2^0) \oplus x_3^0) \oplus R_2^1(x_3^0) \oplus x_4^0$. The output of R_1^4 can be

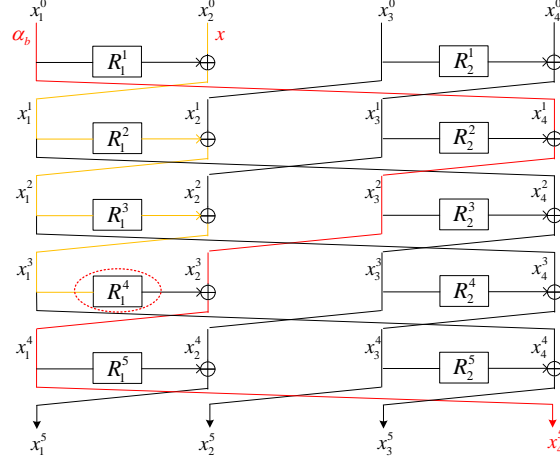

Figure 7 5-round Distinguisher on RC6/CLEFIA-like GFS with $2d = 4$

expressed as $x_1^0 \oplus x_4^5 \oplus R_2^2(R_2^1(x_3^0) \oplus x_4^0)$. Through R_1^4 , we obtain the following equation

$$R_1^4(R_1^3(R_1^2(R_1^1(x_1^0) \oplus x_2^0) \oplus x_3^0) \oplus R_2^1(x_3^0) \oplus x_4^0) = x_1^0 \oplus x_4^5 \oplus R_2^2(R_2^1(x_3^0) \oplus x_4^0) \quad (6)$$

Let $x_1^0 = \alpha_b$, $x_2^0 = x$, x_3^0 , x_4^0 be constants, it becomes

$$R_1^4(R_1^3(R_1^2(R_1^1(\alpha_b) \oplus x) \oplus x_3^0) \oplus R_2^1(x_3^0) \oplus x_4^0) = \alpha_b \oplus x_4^5 \oplus R_2^2(R_2^1(x_3^0) \oplus x_4^0) \quad (7)$$

$$\begin{aligned} f_4 : \{0, 1\} \times \{0, 1\}^n &\rightarrow \{0, 1\}^n \\ b, x &\mapsto \alpha_b \oplus x_4^5 \oplus R_2^2(R_2^1(x_3^0) \oplus x_4^0), \text{ where } x_1^5 || x_2^5 || x_3^5 || x_4^5 = E(\alpha_b, x) \\ f_4(b, x) &= R_1^4(R_1^3(R_1^2(R_1^1(\alpha_b) \oplus x) \oplus x_3^0) \oplus R_2^1(x_3^0) \oplus x_4^0) \end{aligned}$$

Thus $f_4(b, x) = f_4(b \oplus 1, x \oplus R_1^1(\alpha_0) \oplus R_1^1(\alpha_1))$. Therefore, function f_4 satisfies Simon's promise with $s = 1 || R_1^1(\alpha_0) \oplus R_1^1(\alpha_1)$.

Case Study, $2d = 6$:

As shown in Figure 8 with $2d = 6$, for the input of round function R_1^6 about x_j^0 for $1 \leq j \leq 6$, we compute its symbolic expression: $R_1^5(R_1^4(R_1^3(R_1^2(R_1^1(x_1^0) \oplus x_2^0) \oplus x_3^0) \oplus R_2^1(x_3^0) \oplus x_4^0) \oplus R_2^2(R_2^1(x_3^0) \oplus x_4^0) \oplus x_5^0) \oplus R_3^2(R_2^2(R_2^1(x_3^0) \oplus x_4^0) \oplus x_5^0) \oplus R_3^1(x_5^0) \oplus x_6^0$.

The output of R_1^6 can be expressed as $x_1^0 \oplus x_6^7 \oplus R_3^2(R_3^1(x_5^0) \oplus x_6^0) \oplus R_4^2(R_2^3(R_2^2(R_2^1(x_3^0) \oplus x_4^0) \oplus x_5^0) \oplus R_3^1(x_5^0) \oplus x_6^0)$. Through R_1^4 , we obtain the following

$$\begin{aligned} R_1^6[R_1^5(R_1^4(R_1^3(R_1^2(R_1^1(x_1^0) \oplus x_2^0) \oplus x_3^0) \oplus R_2^1(x_3^0) \oplus x_4^0) \oplus R_2^2(R_2^1(x_3^0) \oplus x_4^0) \oplus x_5^0) \oplus R_3^2(R_2^2(R_2^1(x_3^0) \oplus x_4^0) \oplus x_5^0) \\ \oplus R_3^1(x_5^0) \oplus x_6^0] = x_1^0 \oplus x_6^7 \oplus R_3^2(R_3^1(x_5^0) \oplus x_6^0) \oplus R_4^2(R_2^3(R_2^2(R_2^1(x_3^0) \oplus x_4^0) \oplus x_5^0) \oplus R_3^1(x_5^0) \oplus x_6^0) \end{aligned} \quad (8)$$

Let $x_1^0 = \alpha_b$, $x_2^0 = x$, x_3^0 , x_4^0 , x_5^0 , x_6^0 be constants, it becomes

$$\begin{aligned} R_1^6[R_1^5(R_1^4(R_1^3(R_1^2(R_1^1(\alpha_b) \oplus x) \oplus x_3^0) \oplus R_2^1(x_3^0) \oplus x_4^0) \oplus R_2^2(R_2^1(x_3^0) \oplus x_4^0) \oplus x_5^0) \oplus R_3^2(R_2^2(R_2^1(x_3^0) \oplus x_4^0) \oplus x_5^0) \\ \oplus R_3^1(x_5^0) \oplus x_6^0] = \alpha_b \oplus x_6^7 \oplus R_3^2(R_3^1(x_5^0) \oplus x_6^0) \oplus R_4^2(R_2^3(R_2^2(R_2^1(x_3^0) \oplus x_4^0) \oplus x_5^0) \oplus R_3^1(x_5^0) \oplus x_6^0) \end{aligned} \quad (9)$$

$$\begin{aligned} f_6 : \{0, 1\} \times \{0, 1\}^n &\rightarrow \{0, 1\}^n \\ b, x &\mapsto \alpha_b \oplus x_6^7 \oplus R_3^2(R_3^1(x_5^0) \oplus x_6^0) \oplus R_4^2(R_2^3(R_2^2(R_2^1(x_3^0) \oplus x_4^0) \oplus x_5^0) \oplus R_3^1(x_5^0) \oplus x_6^0), \\ &\text{ where } x_1^5 || x_2^5 || x_3^5 || x_4^5 || x_5^5 || x_6^5 = E(\alpha_b, x) \\ f_6(b, x) &= R_1^6[R_1^5(R_1^4(R_1^3(R_1^2(R_1^1(\alpha_b) \oplus x) \oplus x_3^0) \oplus R_2^1(x_3^0) \oplus x_4^0) \oplus R_2^2(R_2^1(x_3^0) \oplus x_4^0) \oplus x_5^0) \\ &\oplus R_3^2(R_2^2(R_2^1(x_3^0) \oplus x_4^0) \oplus x_5^0) \oplus R_3^1(x_5^0) \oplus x_6^0] \end{aligned}$$

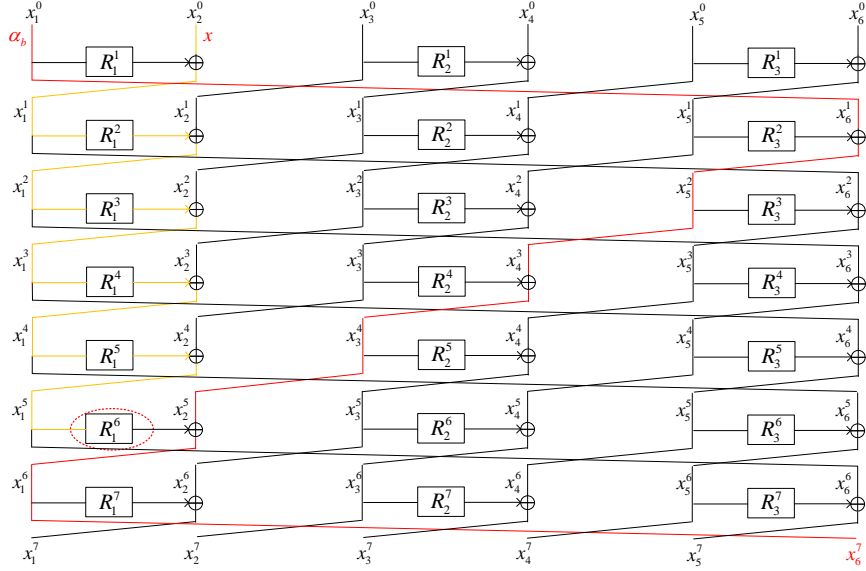

Figure 8 7-round Distinguisher on RC6/CLEFIA-like GFS with $2d = 6$

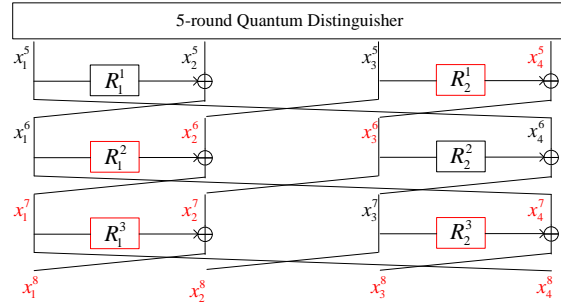

Figure 9 8-round Quantum Key-recovery Attack on RC/CLEFIA-like GFS with $2d = 4$

Thus $f_6(b, x) = f_6(b \oplus 1, x \oplus R_1^1(\alpha_0) \oplus R_1^1(\alpha_1))$. Therefore, function f_6 satisfies Simon's promise with $s = 1 || R_1^1(\alpha_0) \oplus R_1^1(\alpha_1)$.

Similarly, for the $2d$ -branch version, we can get corresponding function f_{2d} satisfies Simon's promise with $s = 1 || R_1^1(\alpha_0) \oplus R_1^1(\alpha_1)$ at $2d$ th round.

4.2 Quantum Key-recovery Attacks on Type-2 (RC6/CLEFIA-like) GFS

Firstly, we study the quantum key-recovery attack on RC6/CLEFIA-like GFS with $2d = 4$ branches. Similarly, combining Simon's and Grover's algorithms, 3 rounds are appended under the 5-round distinguisher to launch the attack. As shown in Figure 9, there are $4n$ -bit key needed to be guessed by Grover's algorithm, which are highlighted in the red boxes of round functions. Thus, the 8-round quantum key-recovery attack needs about 2^{2n} queries and $\mathcal{O}(n^2)$ qubits. If we attack $r > 8$ rounds, we need guess $4n + (r - 8) \times 2n$ key bits by Grover's algorithm. Thus, the time complexity is $2^{2n + \frac{(r-8) \times 2n}{2}} = 2^{(r-6)n}$.

Then, for the case of $2d = 6$, we append 5 rounds after the 7-round distinguisher to launch the 12-round quantum key-recovery attack as shown in Figure 10. $9n$ key bits highlighted in red need to be guessed by Grover's algorithm. Thus, the time complexity is $2^{\frac{9n}{2}}$ and $\mathcal{O}(n^2)$ qubits are needed. When we attack $r > 12$ rounds, $9n + (r - 12) \times 3n$ key bits need to be guessed by Grover's algorithm. So the time complexity is $2^{\frac{9n}{2} + \frac{(r-12) \times 3n}{2}} = 2^{\frac{(r-9)3n}{2}}$.

Generally, for $2d \geq 4$, we could get $(2d + 1)$ -round quantum distinguisher. We append $2d - 1$ rounds

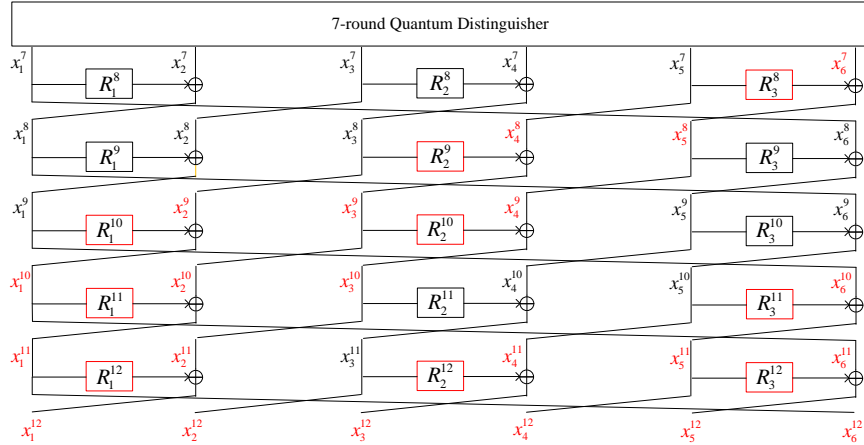

Figure 10 12-round Quantum Key-recovery Attack on RC/CLEFIA-like GFS with $2d = 6$

under the quantum distinguisher to attack $r_0 = 4d$ round RC/CLEFIA-like GFS. Similarly, we need to guess d^2n -bit key by Grover's algorithm. Thus, for r_0 rounds, the time complexity is $\frac{d^2n}{2}$ queries, and $\mathcal{O}(n^2)$ qubits are needed. If we attack $r > r_0$ rounds, we need guess $d^2n + (r - r_0)dn$ key bits by Grover's algorithm. Thus, the time complexity is $2^{\frac{d^2 + (r - r_0)d}{2}n}$.

If we use the quantum brute force search (Grover search) to recover the key, for r -round $2d$ -branch cipher, totally, rdn -bit key need to be found, the complexity is $2^{rdn/2}$. Thus, our attack is better than the quantum brute force search (Grover search) by a factor $2^{rdn/2 - \frac{d^2 + (r - r_0)d}{2}n} = 2^{\frac{3d^2n}{2}}$.

5 Conclusion

This paper studies quantum distinguishers and quantum key-recovery attacks on two generalized Feistel schemes (GFS): Type-1 (CAST256-like) and Type-2 (RC6/CLEFIA-like) GFS. For d -branch Type-1 GFS, we introduce $(2d - 1)$ -round quantum distinguishers with polynomial time. For $2d$ -branch Type-2 GFS, we give $(2d + 1)$ -round quantum distinguishers with polynomial time. Classically, Moriai and Vaudenay [MV00] proved that a 7-round 4-branch Type-1 GFS and 5-round 4-branch Type-2 GFS are secure pseudo-random permutations. Obviously, they are no longer secure in quantum setting.

Using the above quantum distinguishers, we introduce generic quantum key-recovery attacks by applying the combination of Simon's and Grover's algorithms recently proposed by Leander and May. We denote n as the bit length of a branch. For $(d^2 - d + 2)$ -round Type-1 GFS with d branches, the time complexity is $2^{(\frac{1}{2}d^2 - \frac{3}{2}d + 2) \cdot \frac{n}{2}}$, which is better than the quantum brute force search (Grover search) by a factor $2^{(\frac{1}{4}d^2 + \frac{1}{4}d)n}$. For $4d$ -round Type-2 GFS with $2d$ branches, the time complexity is $2^{\frac{d^2n}{2}}$, which is better than the quantum brute force search by a factor $2^{\frac{3d^2n}{2}}$.

Open Discussion: The Chinese standard block cipher SMS4 is based on a different contracting Feistel scheme, we denote it as SMS4-like GFS. For the 4-branch case, we could find a 5-round quantum distinguisher that works with $\mathcal{O}(n)$. However, Zhang and Wu [ZW09] proved that 7-round 4-branch SMS4-like GFS is a pseudo-random permutation. So our quantum distinguisher does not violate Zhang and Wu's claim. It will be interesting to find quantum distinguisher with more rounds.

Conflict of interest The authors declare that they have no conflict of interest.

References

- ADK⁺14 Martin R Albrecht, Benedikt Driessen, Elif Bilge Kavun, Gregor Leander, Christof Paar, and Tolga Yalcin. Block ciphers focus on the linear layer (feat. pride). pages 57–76, 2014.

- BCG⁺12 Julia Borghoff, Anne Canteaut, Tim Güneysu, Elif Bilge Kavun, Miroslav Knezevic, Lars R. Knudsen, Gregor Leander, Ventzislav Nikov, Christof Paar, Christian Rechberger, Peter Rombouts, Søren S. Thomsen, and Tolga Yalçin. PRINCE - A Low-Latency Block Cipher for Pervasive Computing Applications - Extended Abstract. In Xiaoyun Wang and Kazue Sako, editors, *ASIACRYPT 2012*, volume 7658 of *Lecture Notes in Computer Science*, pages 208–225. Springer, 2012.
- BHMT00 Gilles Brassard, Peter Hoyer, Michele Mosca, and Alain Tapp. Quantum amplitude amplification and estimation. *arXiv: Quantum Physics*, 2000.
- BZ13 Dan Boneh and Mark Zhandry. Secure signatures and chosen ciphertext security in a quantum computing world. pages 361–379, 2013.
- DW17 Xiaoyang Dong and Xiaoyun Wang. Quantum key-recovery attack on feistel structures. Cryptology ePrint Archive, Report 2017/1199, 2017. <https://eprint.iacr.org/2017/1199>.
- FNS75 H Feistel, W A Notz, and J L Smith. Some cryptographic techniques for machine-to-machine data communications. *Proceedings of the IEEE*, 63(11):1545–1554, 1975.
- Gro96 Lov K Grover. A fast quantum mechanical algorithm for database search. *symposium on the theory of computing*, pages 212–219, 1996.
- Int10 International Organization for Standardization(ISO). International Standard- ISO/IEC 18033-3, Information technology-Security techniques-Encryption algorithms -Part 3: Block ciphers. 2010.
- KLLN16 Marc Kaplan, Gaetan Leurent, Anthony Leverrier, and Maria Nayaplasencia. Breaking symmetric cryptosystems using quantum period finding. *international cryptology conference*, 9815:207–237, 2016.
- KM10 Hidenori Kuwakado and Masakatu Morii. Quantum distinguisher between the 3-round feistel cipher and the random permutation. *International symposium on information theory*, pages 2682–2685, 2010.
- KM12 Hidenori Kuwakado and Masakatu Morii. Security on the quantum-type even-mansour cipher. *International symposium on information theory and its applications*, pages 312–316, 2012.
- LM17 Gregor Leander and Alexander May. Grover meets simon - quantumly attacking the fx-construction. In *Advances in Cryptology - ASIACRYPT 2017 - 23rd International Conference on the Theory and Applications of Cryptology and Information Security, Hong Kong, China, December 3-7, 2017, Proceedings, Part II*, pages 161–178, 2017.
- LR88 Michael G Luby and Charles Rackoff. How to construct pseudorandom permutations from pseudorandom functions. *SIAM Journal on Computing*, 17(2):373–386, 1988.
- MV00 Shiho Moriai and Serge Vaudenay. *On the Pseudorandomness of Top-Level Schemes of Block Ciphers*, pages 289–302. Springer Berlin Heidelberg, Berlin, Heidelberg, 2000.
- Sho97 Peter W Shor. Polynomial-time algorithms for prime factorization and discrete logarithms on a quantum computer. *SIAM Journal on Computing*, 26(5):1484–1509, 1997.
- Sim97 Daniel R. Simon. On the power of quantum computation. *SIAM Journal on Computing*, 26(5):1474–1483, 1997.
- TP17 Tsuyoshi Takagi and Thomas Peyrin, editors. *Advances in Cryptology - ASIACRYPT 2017 - 23rd International Conference on the Theory and Applications of Cryptology and Information Security, Hong Kong, China, December 3-7, 2017, Proceedings*, volume 10624 of *Lecture Notes in Computer Science*. Springer, 2017.
- ZMI90 Yuliang Zheng, Tsutomu Matsumoto, and Hideki Imai. *On the Construction of Block Ciphers Provably Secure and Not Relying on Any Unproved Hypotheses*, pages 461–480. Springer New York, New York, NY, 1990.
- ZW09 Liting Zhang and Wenling Wu. Pseudorandomness and super pseudorandomness on the unbalanced feistel networks with contracting functions. *Chinese Journal of Computers*, 32(07), 2009.